



**ANNOVI  
REVERBERI**®  
The Power of Experience



POWER GARDEN WHEELBARROW SPRAYERS BROCHURE

**CATALOGO GIARDINAGGIO ED IRRORAZIONE**

1710

Dal 1958 nel settore delle  
pompe ad alta pressione

*In the high pressure pump  
sector since 1958*



- 1- Sede centrale di Modena  
*Modena headquarters*
- 2- Stabilimento di Bomperto  
*Bomperto plant*
- 3- Centro logistico (Bomperto)  
*Logistics Centre (Bomperto)*
- 4- Filiale di Minneapolis, MN (USA)  
*North American Branch, Minneapolis, MN (USA)*
- 5- Stabilimento di Shanghai (PRC)  
*Shanghai plant (PRC)*



# ANNOVI<sup>®</sup> REVERBERI

The Power of Experience



I molti anni di esperienza nelle pompe per l'irrigazione e l'elevato know-how acquisito nel corso degli anni hanno permesso ad Annovi Reverberi di realizzare una innovativa gamma di carriole e carrelli per il giardinaggio, il diserbo e la disinfestazione.

Oltre ad un design ricercato, questi carrelli sono caratterizzati da standard qualitativi di massimo livello.

*The many years of experience in spraying pumps and the vast amount of know-how obtained during these years has allowed Annovi Reverberi to come up with an innovative line of wheelbarrows sprayers for gardening, weed killing and pest control.*

*In addition to the stylish design, these units are characterised as having the highest quality standards.*

Pag. 06

**CAR 75**

Pag. 07

**CAR  
90/H**

Pag. 08

**CAR  
90/P**

Pag. 09

**CAR  
130/H**

Pag. 10

**CAR  
130/P**

Pag. 11

**CAR  
A**

Pag. 11

**CAR  
35**

Pag. 12

**CAR  
50**

Pag. 14

**Gruppi elettropompa**  
*Electric motor pump  
assemblies*

Pag. 19

**Gruppi motopompa**  
*Motor-driven pump  
assemblies*





# ANNOVI REVERBERI®

The Power of Experience



Avvolgitubo PL con blocco  
manuale antisrotolamento  
Hose reel PL with manual  
stop to prevent hose  
unwinding



Supporto portalancia  
Lance holding bracket



Porta accessori  
(per modelli senza  
avvolgitubo)  
Accessories holder  
(for model without  
hose reel)



Tanica lavamani  
integrata 5 litri  
Integrated 5 litre  
handwash tank

# PLUS

Indicatore livello esterno con  
banda graduata  
External level indicator with  
graduated scale



Cisterna a svuotamento totale  
Total drainage tank



Filtro serbatoio  
Tank filter



Ruote pneumatiche gonfiabili  
Inflatable rubber wheels





# CAR 75



Cod. 3929

Modello Model	Codice Code	Dimensioni scatola Box dimensions LxWxH (cm)	Peso Weight kg
<b>CAR 75</b>	<b>3929</b>	90x67x68	21
<b>PL Hose-reel</b>	<b>3921</b>	50x32x45	11

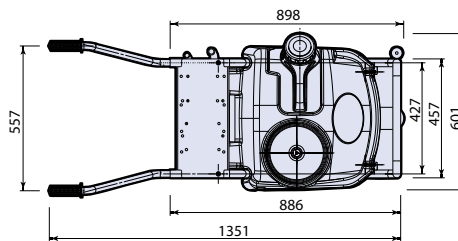
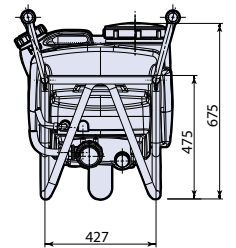
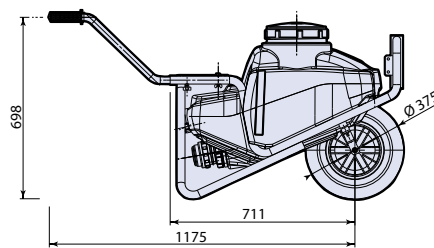
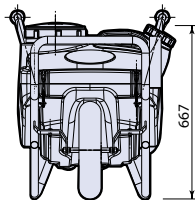

**Carriola a una ruota** completa di serbatoio in polietilene da 75L +10 m di tubo in gomma 8x13mm, lancia 60 cm, tanica lavamani 5L.

**Wheelbarrow** c/w polyethylene 75L tank, 10m hose, 60cm lance and 5L hand washer tank.

## Hose-reel cod.3921



**Avvolgitubo PL**  
(optional)  
**PL Hose-reel**  
(optional)  
Gomma telata  
Rubber hose  
ø8x13mm L 50m

sp\_avvolgitubo\_PL\_L.pdf  
MI 91010



AR DUE EM/ET



AR DUE S



AR 202 EM/ET



AR 202 S



AR 252 EM/ET



AR 252 S

Modello Model	Portata Delivery L/min	Pressione Pressure bar	Caratteristiche motore Engine characteristics	Codice Code	Dimensioni scatola Box dimensions LxWxH (cm)	Peso Weight Kg	
AR DUE EM	13	20	1 ~	1.2 HP	32171	51x25x35	12
AR DUE ET	13	20	3 ~	1.2 HP	32172	51x25x35	12
AR DUE S	13	20	CM 46/CE	2 HP	32173	51x25x35	10
AR DUE S	13	20	OLEOMAC S50	1.8 HP	32174	51x25x35	9
AR 202 EM	23,2	20	1 ~	1.2 HP	32175	51x27x35	17
AR 202 ET	23,2	20	3 ~	1.2 HP	32176	51x27x35	17
AR 202 S	23,2	20	CM 46/CE	2 HP	32177	51x25x35	12
AR 202 S	23,2	20	OLEOMAC S50	1.8 HP	32178	51x25x35	11
AR 202 S	23,2	20	RATO EHRS 100	2.5 HP	32197	45x36x44	13
AR 202 S	23,2	20	AXO AMG 101	2.5 HP	32179	45x36x44	13
AR 252 EM <sup>(a)</sup>	24,6	25	1 ~	1.5 HP	32180	51x27x35	18
AR 252 ET <sup>(a)</sup>	24,6	25	3 ~	1.5 HP	32181	51x27x35	18
AR 252 S <sup>(a)</sup>	24,6	25	RATO EHRS 100	2.5 HP	32185	45x36x44	14
AR 252 S <sup>(a)</sup>	24,6	25	RATO EHR 160	5.5 HP	32255	50x40x49	21
AR 252 S <sup>(a)</sup>	24,6	25	AXO AMG 101	2.5 HP	32182	45x36x44	14
AR 252 S <sup>(a)</sup>	24,6	25	AXO AMG 121	4 HP	32183	50x40x49	20
AR 252 S <sup>(a)</sup>	24,6	25	B & S 550	3.5 HP	32184	50x40x49	20
AR 252 S <sup>(a)</sup>	24,6	25	HONDA GP160	4.8 HP	32186	50x40x49	21
AR 252 S <sup>(a)</sup>	24,6	25	HONDA GX120	3.5 HP	32187	50x40x49	20

<sup>(a)</sup> Con gruppo regolazione, completo di manometro e rubinetto. / With regulation unit, pressure gauge and ball valve.

CM 3008600  
sp\_car75.pdf  
MI 91009  
DI 3008500



# CAR 90 / H



Cod. 3930

Modello Model	Codice Code	Dimensioni scatola Box dimensions LxWxH (cm)	Peso Weight kg
<b>CAR 90 / H</b>	<b>3930</b>	90x67x68	23
<b>Hose-reel</b>	<b>(PL) 3921</b>	50x32x45	11
	<b>41682</b>	65x47x68	21

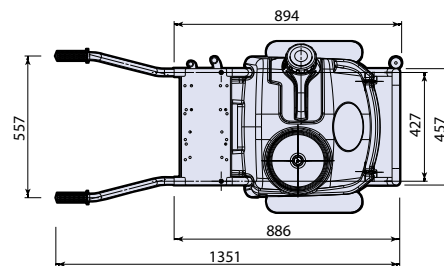
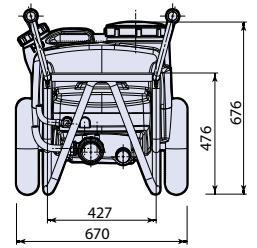
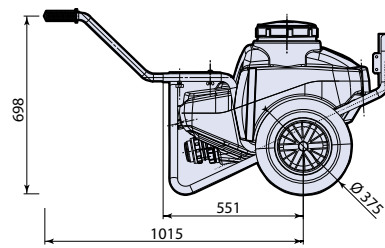
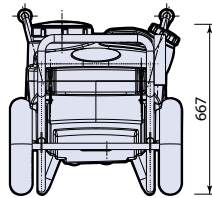

**Carrello a due ruote** completo di serbatoio in polietilene da 90L +10 m di tubo in gomma 8x13mm, lancia 60 cm, tanica lavamani 5L  
**2 -wheeled trolley** c/w polyethylene tank 90L, 10m hose, 60cm lance and 5L hand washer tank.

## Hose-reel cod.3921



**Avvolgitubo PL**  
(optional)  
**PL Hose-reel**  
(optional)  
 Gomma telata  
 Rubber hose  
 ø8x13mm L 50m

## Hose-reel cod.41682



**Avvolgitubo** (optional)  
**Hose-reel** (optional)  
 Gomma telata  
 Rubber hose  
 ø8x13mm L 100m



AR DUE EM / ET



AR 252 S

Modello Model	Portata Delivery L/min	Pressione Pressure bar	Caratteristiche motore Engine characteristics		Codice Code	Dimensioni scatola Box dimensions LxWxH (cm)	Peso Weight Kg
AR DUE EM	13	20	1 ~	1.2 HP	32171	51x25x35	12
AR DUE ET	13	20	3 ~	1.2 HP	32172	51x25x35	12
AR DUE S	13	20	CM 46/CE	2 HP	32173	51x25x35	10
AR DUE S	13	20	OLEOMAC S50	1.8 HP	32174	51x25x35	9
AR 202 EM	23,2	20	1 ~	1.2 HP	32175	51x27x35	17
AR 202 ET	23,2	20	3 ~	1.2 HP	32176	51x27x35	17
AR 202 S	23,2	20	CM 46/CE	2 HP	32177	51x25x35	12
AR 202 S	23,2	20	OLEOMAC S50	1.8 HP	32178	51x25x35	11
AR 202 S	23,2	20	RATO EHRS 100	2.5 HP	32197	45x36x44	13
AR 202 S	23,2	20	AXO AMG 101	2.5 HP	32179	45x36x44	13
AR 252 EM <sup>(a)</sup>	24,6	25	1 ~	1.5 HP	32180	51x27x35	18
AR 252 ET <sup>(a)</sup>	24,6	25	3 ~	1.5 HP	32181	51x27x35	18
AR 252 S <sup>(a)</sup>	24,6	25	RATO EHRS 100	2.5 HP	32185	45x36x44	14
AR 252 S <sup>(a)</sup>	24,6	25	RATO EHR 160	5.5 HP	32255	50x40x49	21
AR 252 S <sup>(a)</sup>	24,6	25	AXO AMG 101	2.5 HP	32182	45x36x44	14
AR 252 S <sup>(a)</sup>	24,6	25	AXO AMG 121	4 HP	32183	50x40x49	20
AR 252 S <sup>(a)</sup>	24,6	25	B & S 550	3.5 HP	32184	50x40x49	20
AR 252 S <sup>(a)</sup>	24,6	25	HONDA GP160	4.8 HP	32186	50x40x49	21
AR 252 S <sup>(a)</sup>	24,6	25	HONDA GX120	3.5 HP	32187	50x40x49	20

<sup>(a)</sup> Con gruppo regolazione, completo di manometro e rubinetto. / With regulation unit, pressure gauge and ball valve.

CM 3008601  
 SP\_CAR90;pdf  
 MI 91009  
 DI 3008501



# CAR 90/P



Cod. 3931

Modello Model	Codice Code	Dimensioni scatola Box dimensions LxWxH (cm)	Peso Weight kg
<b>CAR 90 / P</b>	<b>3931</b>	90x67x68	24
<b>Hose-reel</b>	<b>(PL) 3923</b>	50x32x45	13,5
	<b>41684</b>	65x47x68	26

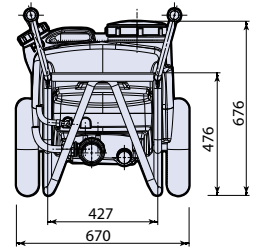
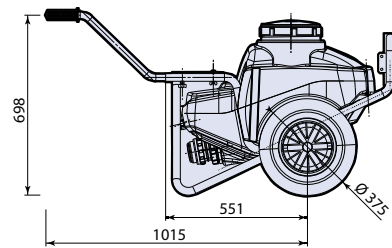
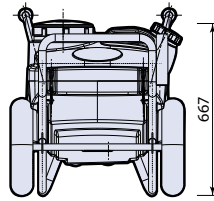

**Carrello a due ruote** completo di serbatoio in polietilene da 90L +10 m di tubo in gomma 10x17mm, lancia 60 cm, tanica lavamani 5L  
**2 -wheeled trolley** c/w polyethylene tank 90L, 10m hose, 60cm lance and 5L hand washer tank.

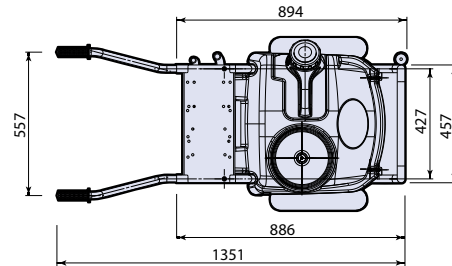

CM 3008601  
 sp\_car90.pdf  
 MI 91009  
 DI 3008501

### Hose-reel cod.3923



**Avvolgitubo PL**  
 (optional)  
**PL Hose-reel**  
 (optional)  
 Gomma telata  
 Rubber hose  
 ø10x17mm L 50m

### Hose-reel cod.41684



**Avvolgitubo** (optional)  
**Hose-reel** (optional)  
 Gomma telata  
 Rubber hose  
 ø10x17mm L 100m



AR 303 EM / ET



AR 303 S

Modello Model	Portata Delivery L/min	Pressione Pressure bar	Caratteristiche motore Engine characteristics		Codice Code	Dimensioni scatola Box dimensions LxWxH (cm)	Peso Weight Kg
AR 303 EM	34,7	35	1 ~	3 HP	32190	68x41x39	37
AR 303 ET	34,7	40	3 ~	4 HP	32193	68x41x39	33
AR 303 S	34,7	40	Rato EHR 160	5.5 HP	32256	68x41x39	29
AR 303 S	34,7	40	Axo AMG 201	6.5 HP	32194	68x41x39	29
AR 303 S	34,7	40	Subaru Ex 17	5.7 HP	32196	68x41x39	29
AR 303 S	34,7	40	Honda GP160	4.8 HP <sup>(NP)</sup>	32198	68x41x39	29
AR 303 S	34,7	40	Honda GX160	4.8 HP <sup>(NP)</sup>	32200	68x41x39	29
AR 403 EM	40,7	30	1 ~	3 HP	32201	68x41x39	35
AR 403 ET	40,7	40	3 ~	5.5 HP	32204	68x41x39	41
AR 403 S	40,7	40	Rato EHR 210	7 HP	32258	68x41x39	29
AR 403 S	40,7	40	Axo AMG 201	6.5 HP	32205	68x41x39	29
AR 403 S	40,7	40	Subaru Ex 17	5.7 HP	32207	68x41x39	29
AR 403 S	40,7	40	Honda GP160	4.8 HP <sup>(NP)</sup>	32208	68x41x39	29
AR 403 S	40,7	40	Honda GX160	4.8 HP <sup>(NP)</sup>	32210	68x41x39	29
AR 403 S	40,7	40	B & S Vanguard	6.5 HP	32209	68x41x39	30
AR 30 EM	36,2	30	1 ~	2.5 HP	32211	68x41x39	31
AR 30 ET	36,2	40	3 ~	4 HP	32215	68x41x39	31
AR 30 S	36,2	40	Rato EHR 160	5.5 HP	32257	68x41x39	30
AR 30 S	36,2	40	Axo AMG 201	6.5 HP	32216	68x41x39	30
AR 30 S	36,2	40	Subaru Ex 17	5.7 HP	32218	68x41x39	30
AR 30 S	36,2	40	Honda GP160	4.8 HP <sup>(NP)</sup>	32220	68x41x39	30
AR 30 S	36,2	40	Honda GX160	4.8 HP <sup>(NP)</sup>	32221	68x41x39	30

<sup>(NP)</sup> Potenza netta. / Net power.



# CAR 130 / H



Cod. 3932

Modello Model	Codice Code	Dimensioni Dimensions LxWxH (cm)	Peso Weight kg
<b>CAR 130 / H</b>	<b>3932</b>	100x76x77	26
<b>Hose-reel</b>	<b>(PL) 3922</b>	50x32x45	11
	<b>41683</b>	65x47x68	21

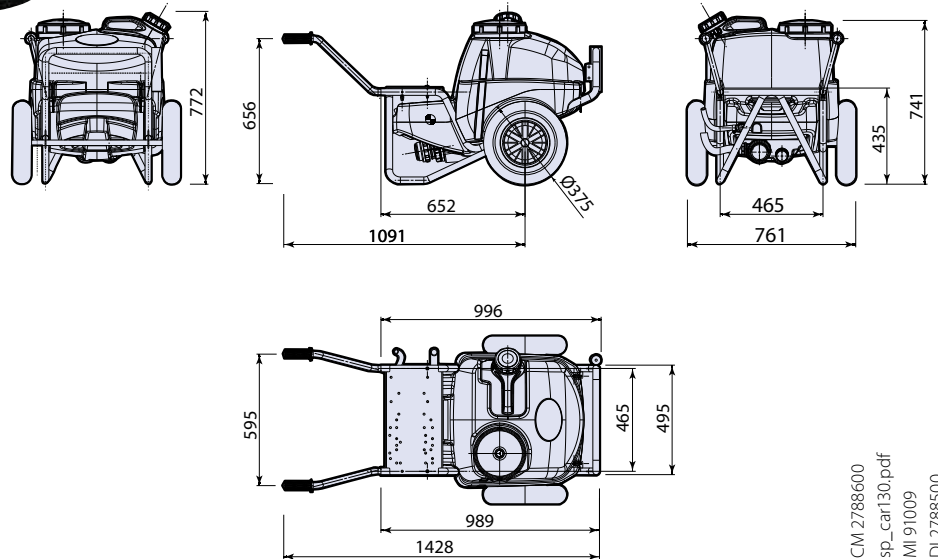

**Carrello a due ruote** completo di serbatoio in polietilene da 130L +10 m di tubo in gomma 8x13mm, lancia 60 cm, tanica lavamani 5L  
**2 -wheeled trolley** c/w polyethylene tank 130L, 10m hose, 60cm lance and hand washer tank.

## Hose-reel cod.3922



**Avvolgitubo PL** (optional)  
**PL Hose-reel** (optional)  
 Gomma telata  
 Rubber hose  
 ø8x13mm L 50m

## Hose-reel cod.41683



**Avvolgitubo** (optional)  
**Hose-reel** (optional)  
 Gomma telata  
 Rubber hose  
 ø8x13mm L 100m



AR DUE EM / ET



AR 252 S

Modello Model	Portata Delivery L/min	Pressione Pressure bar	Caratteristiche motore Engine characteristics		Codice Code	Dimensioni scatola Box dimensions LxWxH (cm)	Peso Weight Kg
AR DUE EM	13	20	1 ~	1.2 HP	32171	51x25x35	12
AR DUE ET	13	20	3 ~	1.2 HP	32172	51x25x35	12
AR DUE S	13	20	CM 46/CE	2 HP	32173	51x25x35	10
AR DUE S	13	20	OLEOMAC S50	1.8 HP	32174	51x25x35	9
AR 202 EM	23,2	20	1 ~	1.2 HP	32175	51x27x35	17
AR 202 ET	23,2	20	3 ~	1.2 HP	32176	51x27x35	17
AR 202 S	23,2	20	CM 46/CE	2 HP	32177	51x25x35	12
AR 202 S	23,2	20	OLEOMAC S50	1.8 HP	32178	51x25x35	11
AR 202 S	23,2	20	RATO EHRS 100	2.5 HP	32197	45x36x44	13
AR 202 S	23,2	20	AXO AMG 101	2.5 HP	32179	45x36x44	13
AR 252 EM <sup>(a)</sup>	24,6	25	1 ~	1.5 HP	32180	51x27x35	18
AR 252 ET <sup>(a)</sup>	24,6	25	3 ~	1.5 HP	32181	51x27x35	18
AR 252 S <sup>(a)</sup>	24,6	25	RATO EHRS 100	2.5 HP	32185	45x36x44	14
AR 252 S <sup>(a)</sup>	24,6	25	RATO EHR 160	5.5 HP	32255	50x40x49	21
AR 252 S <sup>(a)</sup>	24,6	25	AXO AMG 101	2.5 HP	32182	45x36x44	14
AR 252 S <sup>(a)</sup>	24,6	25	AXO AMG 121	4 HP	32183	50x40x49	20
AR 252 S <sup>(a)</sup>	24,6	25	B & S 550	3.5 HP	32184	50x40x49	20
AR 252 S <sup>(a)</sup>	24,6	25	HONDA GP160	4.8 HP	32186	50x40x49	21
AR 252 S <sup>(a)</sup>	24,6	25	HONDA GX120	3.5 HP	32187	50x40x49	20

<sup>(a)</sup> Con gruppo regolazione, completo di manometro e rubinetto. / With regulation unit, pressure gauge and ball valve.

CM 2788600  
 sp\_car130.pdf  
 MI 91009  
 DI 2788500

sp\_avvolgitubo\_PL.pdf  
 MI 91010

sp\_avvolgitubo\_100mt\_CAR90\_130.pdf  
 MI 92889



# CAR 130/P



Cod. 3933

Modello Model	Codice Code	Dimensioni scatola Box dimensions LxWxH (cm)	Peso Weight kg
<b>CAR 130 / P</b>	<b>3933</b>	100x76x77	27
<b>Hose-reel</b>	<b>(PL) 3924</b>	50x32x45	13,5
	<b>41685</b>	65x47x68	26

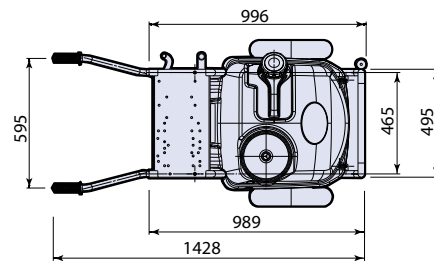
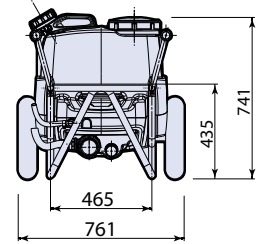
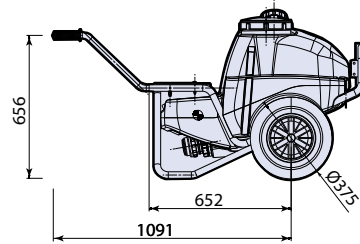
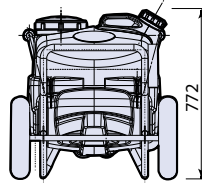

**Carrello a due ruote** completo di serbatoio in polietilene da 130L +10 m di tubo in gomma 10x17mm, lancia 60 cm, tanica lavamani 5L  
**2 -wheeled trolley** c/w polyethylene tank 130L, 10m hose, 60cm lance and hand washer tank.

### Hose-reel cod.3924



**Avvolgitubo PL**  
(optional)  
**PL Hose-reel**  
(optional)  
 Gomma telata  
 Rubber hose  
 ø10x17mm L 50m

### Hose-reel cod.41685



**Avvolgitubo** (optional)  
**Hose-reel** (optional)  
 Gomma telata  
 Rubber hose  
 ø10x17mm L 100m



AR 403 EM / ET



AR 403 S

Modello Model	Portata Delivery L/min	Pressione Pressure bar	Caratteristiche motore Engine characteristics		Codice Code	Dimensioni scatola Box dimensions LxWxH (cm)	Peso Weight Kg
AR 303 EM	34,7	35	1 ~	3 HP	32190	68x41x39	37
AR 303 ET	34,7	40	3 ~	4 HP	32193	68x41x39	33
AR 303 S	34,7	40	Rato EHR 160	5.5 HP	32256	68x41x39	29
AR 303 S	34,7	40	Axo AMG 201	6.5 HP	32194	68x41x39	29
AR 303 S	34,7	40	Subaru Ex 17	5.7 HP	32196	68x41x39	29
AR 303 S	34,7	40	Honda GP160	4.8 HP <sup>(NP)</sup>	32198	68x41x39	29
AR 303 S	34,7	40	Honda GX160	4.8 HP <sup>(NP)</sup>	32200	68x41x39	29
AR 403 EM	40,7	30	1 ~	3 HP	32201	68x41x39	35
AR 403 ET	40,7	40	3 ~	5.5 HP	32204	68x41x39	41
AR 403 S	40,7	40	Rato EHR 210	7 HP	32258	68x41x39	29
AR 403 S	40,7	40	Axo AMG 201	6.5 HP	32205	68x41x39	29
AR 403 S	40,7	40	Subaru Ex 17	5.7 HP	32207	68x41x39	29
AR 403 S	40,7	40	Honda GP160	4.8 HP <sup>(NP)</sup>	32208	68x41x39	29
AR 403 S	40,7	40	Honda GX160	4.8 HP <sup>(NP)</sup>	32210	68x41x39	29
AR 403 S	40,7	40	B & S Vanguard	6.5 HP	32209	68x41x39	30
AR 30 EM	36,2	30	1 ~	2.5 HP	32211	68x41x39	31
AR 30 ET	36,2	40	3 ~	4 HP	32215	68x41x39	31
AR 30 S	36,2	40	Rato EHR 160	5.5 HP	32257	68x41x39	30
AR 30 S	36,2	40	Axo AMG 201	6.5 HP	32216	68x41x39	30
AR 30 S	36,2	40	Subaru Ex 17	5.7 HP	32218	68x41x39	30
AR 30 S	36,2	40	Honda GP160	4.8 HP <sup>(NP)</sup>	32220	68x41x39	30
AR 30 S	36,2	40	Honda GX160	4.8 HP <sup>(NP)</sup>	32221	68x41x39	30

<sup>(NP)</sup> Potenza netta. / Net power.

CM 2788600  
 sp\_car130.pdf  
 MI 91009  
 DI 2788500

sp\_avvolgitubo\_PL.pdf  
 MI 91010

sp\_avvolgitubo\_100mt\_CAR90\_130.pdf  
 MI 92889



Cod. 31526 + AR DUE S

**Carrello** a due ruote con avvolgitubo per 100m di tubo e lancia a leva cm 60 e filtro  
**2-Wheeled trolley** with hose-reel for 100m of hose, 60 cm lance and filter.



Cod. 31527 + AR DUE S



Cod. 31525

Modello Model	Codice Code	Dimensioni Dimensions LxWxH (cm)	Peso Weight kg
<b>CAR / A senza tubo / without hose</b>	<b>31525</b>	90x55x62	5
<b>CAR / A con tubo in fertene / with hose</b>	<b>31527</b>	90x55x62	19
<b>CAR / A con tubo in gommata / with rubber hose</b>	<b>31526</b>	90x55x62	19



AR DUE EM / ET



AR DUE S



AR 202 EM / ET



AR 202 S

Modello Model	Portata Delivery L/min	Pressione Pressure bar	Caratteristiche motore Engine characteristics	Codice Code	Dimensioni scatola Box dimensions LxWxH (cm)	Peso Weight Kg
AR DUE EM	13	20	1 ~ 1.2 HP	32171	51x25x35	12
AR DUE ET	13	20	3 ~ 1.2 HP	32172	51x25x35	12
AR DUE S	13	20	CM 46/CE 2 HP	32173	51x25x35	10
AR DUE S	13	20	OLEOMAC S50 1.8 HP	32174	51x25x35	9
AR 202 EM	23,2	20	1 ~ 1.2 HP	32175	51x27x35	17
AR 202 ET	23,2	20	3 ~ 1.2 HP	32176	51x27x35	17
AR 202 S	23,2	20	CM 46/CE 2 HP	32177	51x25x35	12
AR 202 S	23,2	20	OLEOMAC S50 1.8 HP	32178	51x25x35	11
AR 202 S	23,2	20	RATO EHRS 100 2.5 HP	32197	45x36x44	13
AR 202 S	23,2	20	AXO AMG 101 2.5 HP	32179	45x36x44	13



Cod. 3969 + AR DUE EM

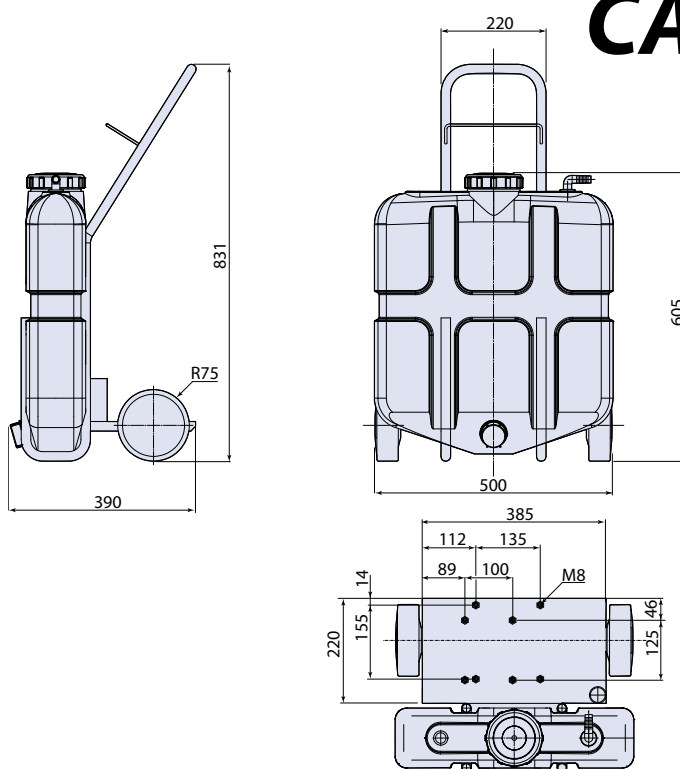

Modello Model	Codice Code	Dimensioni Dimensions LxWxH (cm)	Peso Weight kg
<b>CAR / 35</b>	<b>3969</b>	90x55x62	19

**Carrello** a due ruote completo di serbatoio in polietilene da 30L, m 5 di gomma e lancia a leva cm 60.  
**Wheelbarrow type** with two wheels and built-in 30L polyethylene tank, 5 m rubber hose and 60 cm nozzle.

Modello Model	Portata Delivery L/min	Pressione Pressure bar	Caratteristiche motore Engine characteristics	Codice Code	Dimensioni scatola Box dimensions LxWxH (cm)	Peso Weight Kg
AR DUE EM	13	20	1 ~ 1.2 HP	32171	51x25x35	12
AR DUE ET	13	20	3 ~ 1.2 HP	32172	51x25x35	12
AR DUE S	13	20	CM 46/CE 2 HP	32173	51x25x35	10

sp\_car35.pdf  
 MI 91009  
 DI 1208520





# CAR 50



Cod. 3935

Modello Model	Codice Code	Dimensioni Dimensions LxWxH (cm)	Peso Weight kg
<b>CAR 50</b>	<b>3935</b>	85x58x65	18
<b>Hose-reel</b>	<b>41681</b>	57x57x37	8

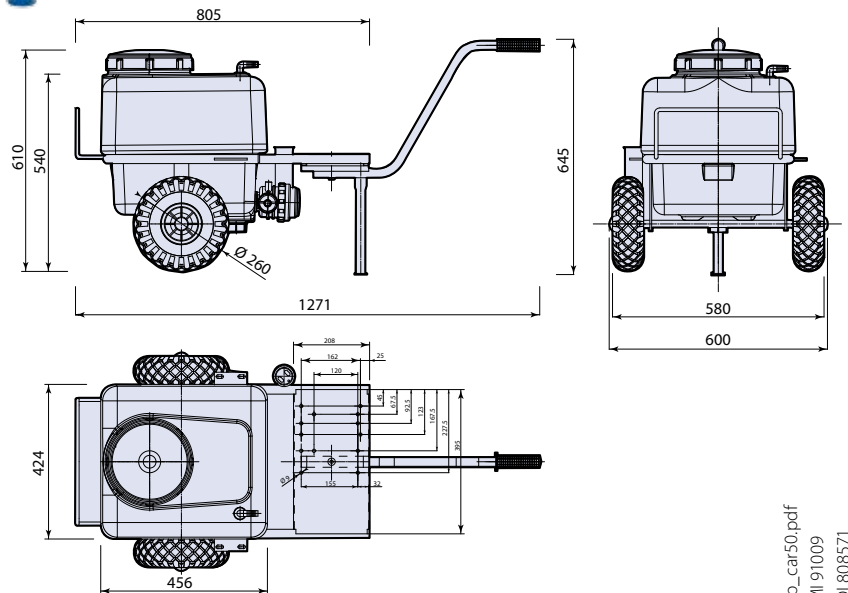

## Hose-reel cod.41681



**Avvolgitubo** (optional)  
**Hose-reel** (optional)  
Gomma telata  
Rubber hose  
ø8x13mm L 50m

Modello Model	Portata Delivery L/min	Pressione Pressure bar	Caratteristiche motore Engine characteristics	Codice Code	Dimensioni scatola Box dimensions LxWxH (cm)	Peso Weight Kg	
AR DUE EM	13	20	1 ~	1.2 HP	32171	51x25x35	12
AR DUE ET	13	20	3 ~	1.2 HP	32172	51x25x35	12
AR DUE S	13	20	CM 46/CE	2 HP	32173	51x25x35	10
AR DUE S	13	20	OLEOMAC S50	1.8 HP	32174	51x25x35	9
AR 202 EM	23,2	20	1 ~	1.2 HP	32175	51x27x35	17
AR 202 ET	23,2	20	3 ~	1.2 HP	32176	51x27x35	17
AR 202 S	23,2	20	CM 46/CE	2 HP	32177	51x25x35	12
AR 202 S	23,2	20	OLEOMAC S50	1.8 HP	32178	51x25x35	11
AR 202 S	23,2	20	RATO EHRS 100	2.5 HP	32197	45x36x44	13
AR 202 S	23,2	20	AXO AMG 101	2.5 HP	32179	45x36x44	13
AR 252 EM (a)	24,6	25	1 ~	1.5 HP	32180	51x27x35	18
AR 252 ET (a)	24,6	25	3 ~	1.5 HP	32181	51x27x35	18
AR 252 S (a)	24,6	25	RATO EHRS 100	2.5 HP	32185	45x36x44	14
AR 252 S (a)	24,6	25	RATO EHR 160	5.5 HP	32255	50x40x49	21
AR 252 S (a)	24,6	25	AXO AMG 101	2.5 HP	32182	45x36x44	14
AR 252 S (a)	24,6	25	AXO AMG 121	4 HP	32183	50x40x49	20
AR 252 S (a)	24,6	25	B & S 550	3.5 HP	32184	50x40x49	20
AR 252 S (a)	24,6	25	HONDA GP160	4.8 HP	32186	50x40x49	21
AR 252 S (a)	24,6	25	HONDA GX120	3.5 HP	32187	50x40x49	20

(a) Con gruppo regolazione, completo di manometro e rubinetto. / With regulation unit, pressure gauge and ball valve.

sp\_car50.pdf  
MI 91009  
DI 808571



AR DUE EM / ET



AR DUE S



AR 202 EM / ET



AR 202 S



AR 252 EM / ET



AR 252 S

# Gruppi Elettropompa

## Electric motor pump assemblies



Versioni Versions	Tipo pompa Pump type	Marca e tipo di motore Motor make and type	Max Power		Net Power		Base Base	Cod. Code	Dim. scatola Box dimensions LxWxH (cm)
			HP	Kw	HP	Kw			

### DC



CM 1208601  
SP\_ardue.pdf  
MI 91406  
DI 1208521

<b>AR DUE</b>	12Volt (Max10 bar) (Corrente continua D.C. electric motor) (Forma 71) Cod. Motore 44624 Ⓢ	0,34	0,25	-	-	Ⓜ	32169	51x25x35
	24Volt (Max10 bar) (Corrente continua D.C. electric motor) (Forma 71) Cod. Motore 44625 Ⓢ	0,34	0,25	-	-	Ⓜ	32170	51x25x35
<b>V.R.I.</b>								

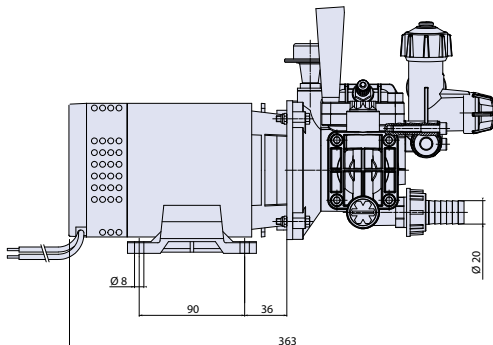
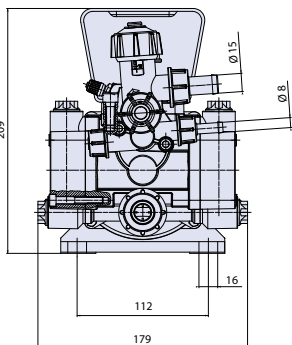

AR DUE VRI DC

### EM - ET



CM 1208601  
SP\_ardue.pdf  
MI 91406  
DI 1208506

<b>AR DUE</b>	Monofase (Max20 bar) (220/240V - 4 poli) (50Hz - Gr. 80) Cod. Motore 4444 Ⓢ	1,2	0,9	-	-	Ⓜ	32171	51x25x35
	Trifase (Max20 bar) (230/400V - 4 poli) (50Hz - Gr. 80) Cod. Motore 4647 Ⓢ	1,2	0,9	-	-	Ⓜ	32172	51x25x35
<b>V.R.I.</b>								

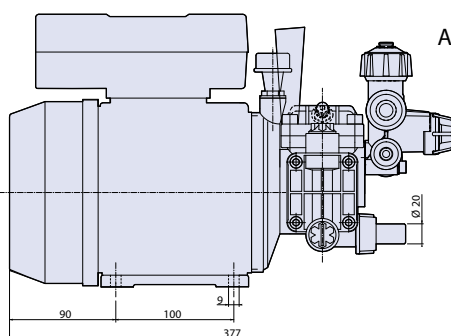
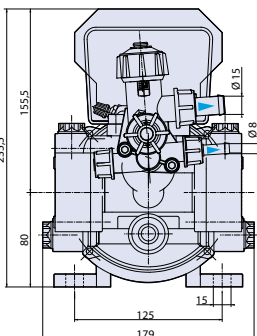

ARDUE VRI EM HP 1,2 - VR 20

- Ⓜ Solo base motore • Motor base only.
- Ⓢ A richiesta motori elettrici HP 2 - 2,5 - 3 - 4 - 5,5 - 7,5 con interruttore e cavo di m 1 (senza spina)
- On request 2 - 2.5 - 3 - 4 - 5.5 - 7.5 HP electric motors with switch and cable (without plug).
- Ⓢ Con interruttore cavo e spina • With switch, cable and plug.



# Gruppi Elettropompa

## Electric motor pump assemblies

Versioni Versions	Tipo pompa Pump type	Marca e tipo di motore Motor make and type		Max Power		Net Power		Base Base	Cod. Code	Dim. scatola Box dimensions LxWxH (cm)
		HP	Kw	HP	Kw					

### EM - ET



CM 808621  
SP\_ar202\_ar252.pdf  
MI 91407  
DI 808541

<b>AR 202</b>	Monofase (220/240V - 2 poli) (50Hz - Gr. 80) Cod. Motore 4030 Ⓢ	1,2	0,9	-	-	Ⓢ	32175	51x27x35
	Trifase (230/400V - 2 poli) (50Hz - Gr. 80) Cod. Motore 4034 Ⓢ	1,2	0,9	-	-	Ⓢ	32176	51x27x35
<b>V.R.I. VR 20</b>								

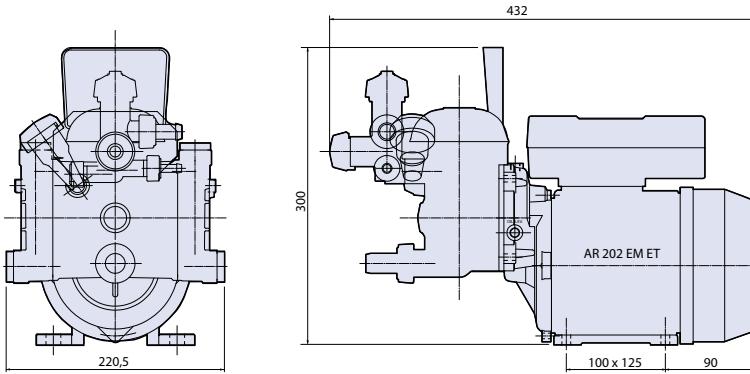

AR 202 VRI ET HP 1,2 - VR20  
con CR cod. 1608

### EM - ET



CM 808621  
SP\_ar202\_ar252.pdf  
MI 91407  
DI 808541

<b>AR 252</b>	Monofase (220/240V - 2 poli) (50Hz - Gr. 80) Cod. Motore 4030 Ⓢ	1,5	1,1	-	-	Ⓢ	32180	51x27x35
	Trifase (230/400V - 2 poli) (50Hz - Gr. 80) Cod. Motore 4798 Ⓢ	1,5	1,1	-	-	Ⓢ	32181	51x27x35
<b>V.R.I. GR 30</b>								

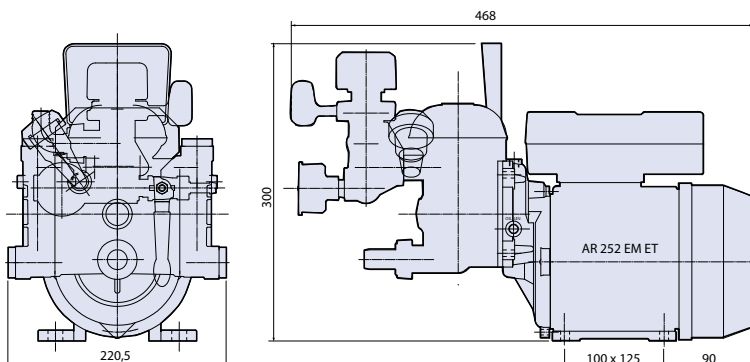

AR 252 VRI ET HP 1,5 - GR30  
con CR cod. 1608



# Gruppi Elettropompa

## Electric motor pump assemblies



Versioni Versions	Tipo pompa Pump type	Marca e tipo di motore Motor make and type	Max Power		Net Power		Base Base	Codice Code	Dim. scatola Box dimensions LxWxH (cm)
			HP	Kw	HP	Kw			

### EM - ET



<b>AR 303</b>	Monofase (Max 25 bar) 4 poli V 220/240 Cod. Motore 4057 <sup>16</sup>	2	1,5	-	-	Ⓜ	32188	68x41x39
	Monofase (Max 30 bar) 4 poli V 220/240 Cod. Motore 4058 <sup>16</sup>	2,5	1,8	-	-	Ⓜ	32189	68x41x39
	Monofase (Max 35 bar) 4 poli V 220/240 Cod. Motore 4077 <sup>16</sup>	3	2,2	-	-	Ⓜ	32190	68x41x39
	Trifase (Max 30 bar) 4 poli V 230/400 Cod. Motore 4059 <sup>16</sup>	2,5	1,8	-	-	Ⓜ	32191	68x41x39
	Trifase (Max 35 bar) 4 poli V 230/400 Cod. Motore 4076 <sup>16</sup>	3	2,2	-	-	Ⓜ	32192	68x41x39
	Trifase (Max 40 bar) 4 poli V 230/400 Cod. Motore 4078 <sup>16</sup>	4	3	-	-	Ⓜ	32193	68x41x39
<b>GR 40</b>								

### EM - ET

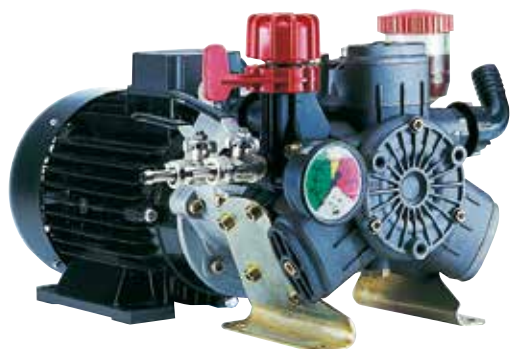

<b>AR 403</b>	Monofase (Max 30 bar) 4 poli V 230/240 Cod. Motore 4077 <sup>16</sup>	3	2,2	-	-	Ⓜ	32201	68x41x39
	Trifase (Max 30 bar) 4 poli V 230/400 Cod. Motore 4076 <sup>16</sup>	3	2,2	-	-	Ⓜ	32202	68x41x39
	Trifase (Max 35 bar) 4 poli V 230/400 Cod. Motore 4078 <sup>16</sup>	4	3	-	-	Ⓜ	32203	68x41x39
	Trifase (Max 40 bar) 4 poli V 230/400 Cod. Motore 4084 <sup>16</sup>	5,5	4	-	-	Ⓜ	32204	68x41x39
<b>GR 40</b>								

Ⓜ Solo base motore • Motor base only.

<sup>16</sup> A richiesta motori elettrici HP 2 - 2,5 - 3 - 4 - 5,5 - 7,5 con interruttore e cavo di m 1 (senza spina).

On request 2 - 2.5 - 3 - 4 - 5.5 - 7.5 HP electric motors with switch and cable (without plug).

<sup>25</sup> Con interruttore cavo e spina • With switch, cable and plug.



# Gruppi Elettropompa

## Electric motor pump assemblies

Versioni Versions	Tipo pompa Pump type	Marca e tipo di motore Motor make and type	Max Power		Net Power		Base Base	Codice Code	Dim. scatola Box dimensions LxWxH (cm)
			HP	Kw	HP	Kw			

### EM - ET



<b>AR 30</b>	Monofase (Max30 bar) 4 poli V 230/240 Cod. Motore 4058 <sup>Ⓜ</sup>	2,5	1,8	-	-	Ⓜ	32211	68x41x39
	Monofase (Max35 bar) 4 poli V 230/240 Cod. Motore 4077 <sup>Ⓜ</sup>	3	2,2	-	-	Ⓜ	32212	68x41x39
	Trifase (Max30 bar) 4 poli V 230/400 Cod. Motore 4059 <sup>Ⓜ</sup>	2,5	1,8	-	-	Ⓜ	32213	68x41x39
	Trifase (Max35 bar) 4 poli V 230/400 Cod. Motore 4076 <sup>Ⓜ</sup>	3	2,2	-	-	Ⓜ	32214	68x41x39
	Trifase (Max40 bar) 4 poli V 230/400 Cod. Motore 4078 <sup>Ⓜ</sup>	4	3	-	-	Ⓜ	32215	68x41x39
<b>GI 40</b>								

### ET

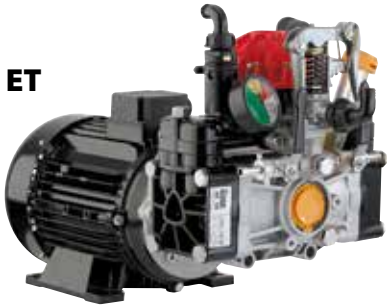

<b>AR 50</b>	Trifase (Max35 bar) 4 poli V 230/400 Cod. Motore 4084 <sup>Ⓜ</sup>	5,5	4	-	-	Ⓜ	32222	68x41x39
	Trifase (Max40 bar) 4 poli V 230/400 Cod. Motore 4085 <sup>Ⓜ</sup>	7,5	5,5	-	-	Ⓜ	32223	68x41x39
<b>GI 40</b>								

DI 628500

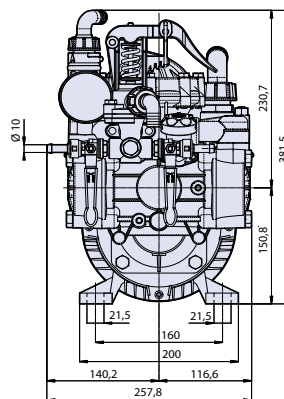
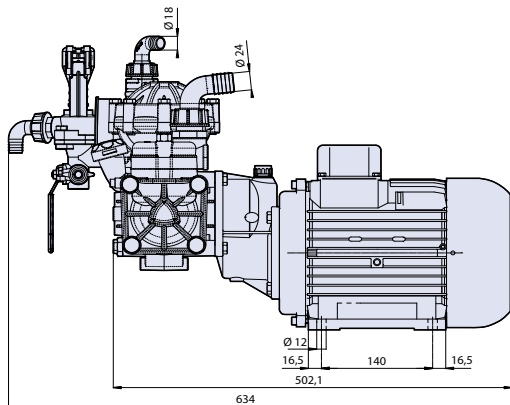

AR 30 GI 40 ET HP 4  
con CR cod. 1624

DI 658516

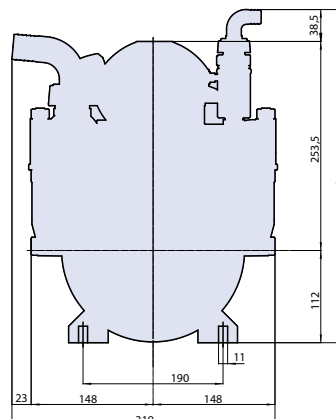
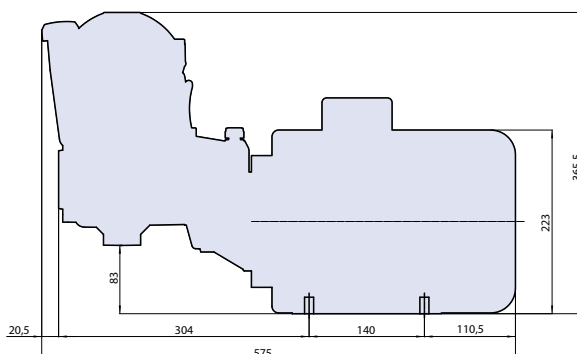

AR 50 GI 40 ET HP 7,5  
con CR cod. 1624

# Gruppi Elettropompa

## Electric motor pump assemblies



Versioni Versions	Tipo pompa Pump type	Marca e tipo di motore Motor make and type	Max Power		Net Power		Base Base	Codice Code	Dim. scatola Box dimensions LxWxH (cm)
			HP	Kw	HP	Kw			

### ET



<b>AR 503</b>	Trifase (Max35 bar) 4 poli V 230/400 Cod. Motore 4084 <sup>Ⓜ</sup>	5,5	4	-	-	Ⓜ	32227	68x41x39
	Trifase 4 poli V 230/400 Cod. Motore 4085 <sup>Ⓜ</sup>	7,5	5,5	-	-	Ⓜ	32228	68x41x39
<b>RM 40 I</b>								

<b>AR 713</b>	Trifase 4 poli V 380/400 Cod. Motore 4085 <sup>Ⓜ</sup>	7,5	5,5	-	-	Ⓜ	32233	90x55x37
<b>VDR 50 I</b>								

<b>AR 813</b>	Trifase (Max40 bar) 4 poli V 380/400 Cod. Motore 4086 <sup>Ⓜ</sup>	8,5	6,2	-	-	Ⓜ	32237	90x55x37
<b>VDR 50 I</b>								

DI1308510

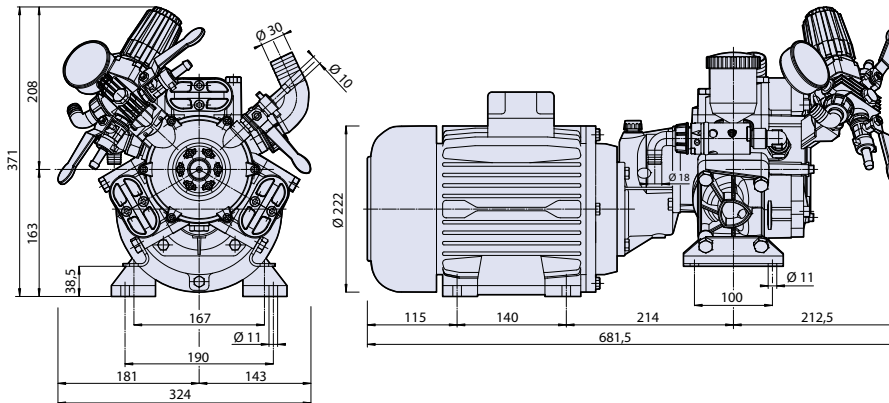

AR 503 GCI ET HP 5,5 - RM40  
con CR cod. 1624

DI1308520

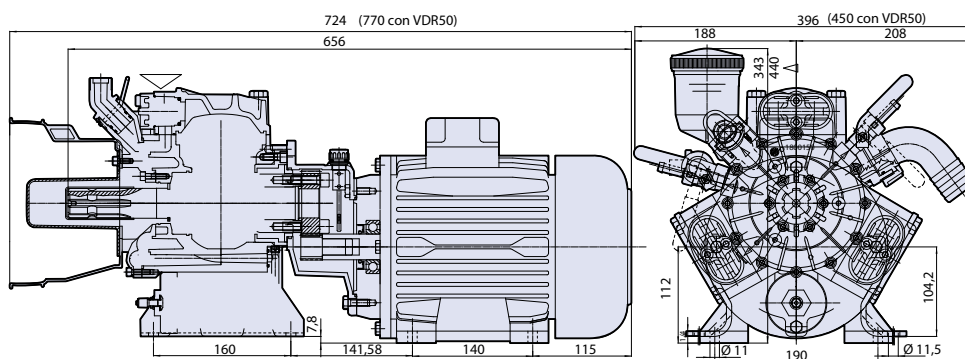

AR 713 GCI ET HP 7,5 - VDR50  
con CR cod. 1624

- Ⓜ Solo base motore • Motor base only.
- Ⓜ A richiesta motori elettrici HP 2 - 2,5 - 3 - 4 - 5,5 - 7,5 con interruttore e cavo di m 1 (senza spina)
- Ⓜ On request 2 - 2.5 - 3 - 4 - 5.5 - 7.5 HP electric motors with switch and cable (without plug).
- Ⓜ Con interruttore cavo e spina • With switch, cable and plug.





# Gruppi Elettropompa

## Electric motor pump assemblies

Versioni Versions	Tipo pompa Pump type	Marca e tipo di motore Motor make and type	Max Power		Net Power		Base Base	Codice Code	Dim. scatola Box dimensions LxWxH (cm)
			HP	Kw	HP	Kw			

### EM - ET



<b>AR 45bp</b>	Monofase, 4 poli, V220/240 Cod. Motore 4058	2,5	1,8	-	-	Ⓜ	32260	-
	Trifase, 4 poli, V230/400 Cod. Motore 4059	2,5	1,8	-	-	Ⓜ	32261	-
<b>G.C.I.</b>								

<b>AR 80bp</b>	Monofase, 4 poli, V220/240, max 15bar Cod. Motore 4077 Ⓜ	3	2,2	-	-	Ⓜ	32245	-
	Trifase, 4 poli, V230/400 Cod. Motore 4078 Ⓜ	4	3	-	-	Ⓜ	32246	-
<b>G.C.I.</b>								

### ET

<b>AR 140bp</b> <b>S.G.C.</b>	Trifase, 4 poli, V230/400 Cod. Motore 4084 Ⓜ	5,5	4	-	-	Ⓜ	32253	-
----------------------------------	--	-----	---	---	---	---	-------	---

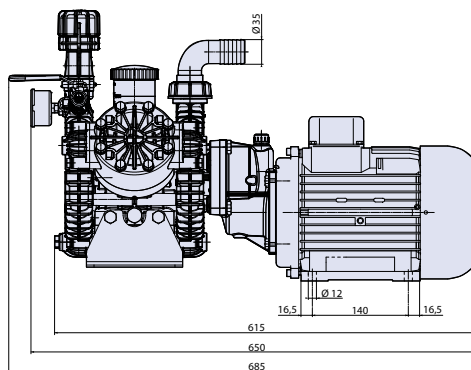
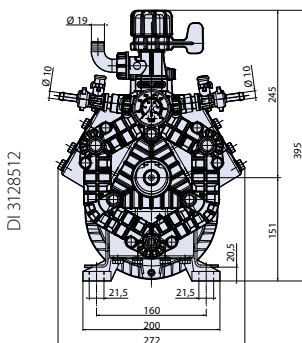

AR 45 bp GCI EM HP 2,5  
con CR cod. 31171

- Ⓜ Solo base motore • Motor base only.
- Ⓜ A richiesta motori elettrici HP 2 - 2,5 - 3 - 4 - 5,5 - 7,5 con interruttore e cavo di m 1 (senza spina)
- Ⓜ On request 2 - 2.5 - 3 - 4 - 5.5 - 7.5 HP electric motors with switch and cable (without plug).
- Ⓜ Con interruttore cavo e spina • With switch, cable and plug.

# Gruppi Motopompa

## Motor-driven pump assemblies



Versioni Versions	Tipo pompa Pump type	Marca e tipo di motore Motor make and type	Max Power		Net Power		Base Base	Codice Code	Dim. scatola Box dimensions LxWxH (cm)
			HP	Kw	HP	Kw			



<b>AR DUE</b>	CM 46/CE Cod. Motore 4023 ⑩	2	1,5	-	-	⑳	32173	51x25x35
	Oleomac S 50 Cod. Motore 4004 ⑩	1,8	1,3	-	-	⑳	32174	51x25x35
<b>V.R.I.</b>								



<b>AR 202</b>	CM 46/CE Cod. Motore 4023 ⑩	2	1,5	-	-	⑳	32177	51x25x35
	Oleomac S 50 Cod. Motore 4004 ⑩	1,8	1,3	-	-	⑳	32178	51x25x35
	Rato EHRS 100 Cod. Motore 44815 ⑩	2,5	1,8	-	-	⑫	32197	45x36x44
	Axo AMG 101 F9 Cod. Motore 44908 ⑩	2,5	1,8	-	-	⑫	32179	45x36x44
<b>V.R.I.</b>								

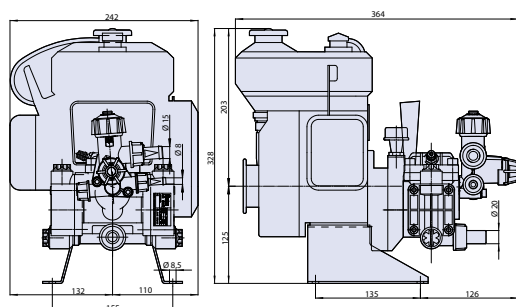

AR DUE S VRI CM 46/CE 2 HP  
con CR cod. 1606

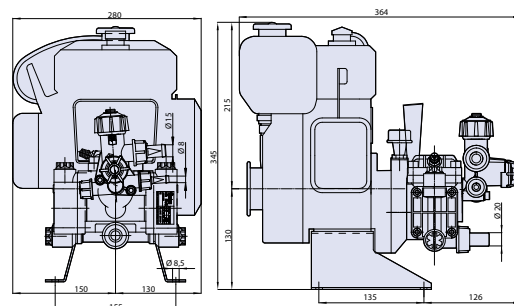

AR DUE S VRI Oleomac S 50 1,8 HP  
con CR cod. 1606

DI 1208507

DI 1208508

- ⑩ Auto-avvolgente incorporato • Built-in recoil.
- ⑫ Solo base motore • Motor base only.
- ⑭ Con avviamento elettrico di serie • With electric start standard.
- ⑮ A richiesta avviamento elettrico e quadro per motori a 4 tempi • Supplement for electric starting and panel for 4-stroke engines
- ⑰ Con base • With base
- ⑱ Motore senza serbatoio carburante • Engine without fuel tank
- ⑳ A richiesta marmitta std (precisare se dx o sx) • Standard silencer available on request (specify right or left)



# Gruppi Motopompa

## Motor-driven pump assemblies

Versioni Versions	Tipo pompa Pump type	Marca e tipo di motore Motor make and type	Max Power		Net Power		Base Base	Codice Code	Dim. scatola Box dimensions LxWxH (cm)
			HP	Kw	HP	Kw			

**S**



<b>AR 252</b>	Rato EHRS 100 Cod. Motore 44815 ⑩	2,5	1,8	-	-	⑫	32185	45x36x44
	Rato EHR 160 Cod. Motore 44906 ⑩	5,5	4,1	-	-	⑫	32255	50x40x49
	Axo AMG 101 F9 Cod. Motore 44908 ⑩	2,5	1,8	-	-	⑫	32182	45x36x44
	Axo AMG 121 Cod. Motore 44896 ⑩	4	3	-	-	⑫	32183	50x40x49
	B&S 550 Series Cod. Motore 4005 ⑩	3,5	2,6	-	-	⑫	32184	50x40x49
	Honda GP 160 Cod. Motore 44804 ⑩	-	-	4,8	3,6	⑫	32186	50x40x49
	Honda GX 120 Cod. Motore 4904 ⑩	-	-	3,5	2,6	⑫	32187	50x40x49
<b>GR 30</b>								

**S**



<b>AR 303</b>	Rato EHR 160 Cod. Motore 44906 ⑩ ⑮	5,5	4,1	-	-	⑫	32256	68x41x39
	Axo AMG 201 Cod. Motore 44909 ⑩ ⑮	6,5	4,8	-	-	⑫	32194	68x41x39
	Subaru EX 17 44708 ⑩ ⑮	5,7	4,2	-	-	⑫	32196	68x41x39
	Honda GP 160 Cod. Motore 44804 ⑩	-	-	4,8	3,6	⑫	32198	68x41x39
	B&S Vanguard 6,5 Cod. 4523 ⑩ ⑮	6,5	4,8	-	-	⑫	32199	68x41x39
<b>GR 40</b>	Honda GX 160 Cod. Motore 44803 ⑩ ⑮	-	-	4,8	3,6	⑫	32200	68x41x39

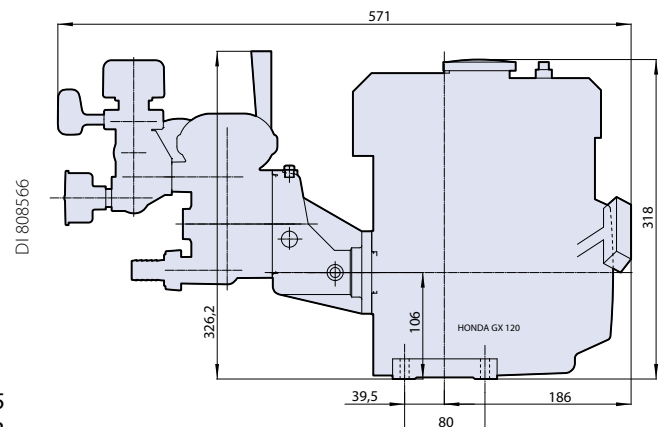

AR 252 S GCI GR 30 - Honda GX120 HP 3,5  
con CR cod. 1613

- ⑩ Auto-avvolgente incorporato • Built-in recoil.
- ⑫ Solo base motore • Motor base only.
- ⑭ Con avviamento elettrico di serie • With electric start standard.
- ⑮ A richiesta avviamento elettrico e quadro per motori a 4 tempi • Supplement for electric starting and panel for 4-stroke engines



# Gruppi Motopompa

## Motor-driven pump assemblies



Versioni Versions	Tipo pompa Pump type	Marca e tipo di motore Motor make and type	Max Power		Net Power		Base Base	Codice Code	Dim. scatola Box dimensions LxWxH (cm)
			HP	Kw	HP	Kw			

**S**



<b>AR 403</b>	Rato EHR 210 Cod. Motore 44907 ⑩	7	5,2	-	-	⑫	32258	68x41x39
	Axo AMG 201 Cod. Motore 44909 ⑩ ⑮	6,5	4,8	-	-	⑫	32205	68x41x39
	Subaru EX 17 Cod. Motore 44708 ⑩ ⑮	5,7	4,2	-	-	⑫	32207	68x41x39
	Honda GP 160 Cod. Motore 44804 ⑩	-	-	4,8	3,6	⑫	32208	68x41x39
	B&S Vanguard 6,5 Cod. 4523 ⑩ ⑮	6,5	4,8	-	-	⑫	32209	68x41x39
	<b>GR 40</b> Honda GX160 Cod. Motore 44803 ⑩ ⑮	-	-	4,8	3,6	⑫	32210	68x41x39

**S**



<b>AR 30</b>	Rato EHR 160 Cod. Motore 44906 ⑩	5,5	4,1	-	-	⑫	32257	68x41x39
	Axo AMG 201 F1 Cod. Motore 44909 ⑩ ⑮	6,5	4,8	-	-	⑫	32216	68x41x39
	Subaru EX 17 Cod. Motore 44708 ⑩ ⑮	5,7	4,2	-	-	⑫	32218	68x41x39
	Honda GP 160 Cod. Motore 44804 ⑩	-	-	4,8	3,6	⑫	32220	68x41x39
	<b>GI 40</b> Honda GX 160 Cod. Motore 44803 ⑩ ⑮	-	-	4,8	3,6	⑫	32221	68x41x39

AR 403 S GCI GR 40 - Honda GX160 HP 14,8  
con CR cod. 1636

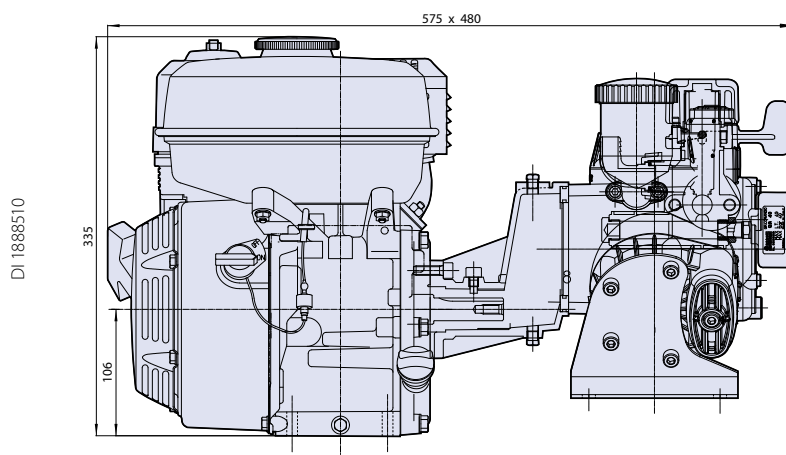

⑫ Con base • With base

⑩ Motore senza serbatoio carburante • Engine without fuel tank

⑮ A richiesta marmitta std (precisare se dx o sx) • Standard silencer available on request (specify right or left)



# Gruppi Motopompa

## Motor-driven pump assemblies

Versioni Versions	Tipo pompa Pump type	Marca e tipo di motore Motor make and type	Max Power		Net Power		Base Base	Codice Code	Dim. scatola Box dimensions LxWxH (cm)
			HP	Kw	HP	Kw			

### S - SD



<b>AR 50</b>	Rato EHR 210 (Max 35 bar) Cod. Motore 44907 ⑩ ⑮	7	5,2	-	-	⑫	32224	90x55x62
	Honda GX 270 Cod. Motore 4925 ⑩ ⑮	-	-	8,4	6,3	⑫	32225	90x55x62
	Lombardini 15LD 350 Cod. Motore 4786 ⑩ ⑮	7,5	5,5	-	-	⑫	32226	90x55x62

<b>AR 503</b>	Rato EHR 270 Cod. Motore 44914 ⑩ ⑮	9	6,7	-	-	⑫	32229	90x55x62
	Subaru EX 27 Cod. Motore 44688 ⑩ ⑮	9	6,7	-	-	⑫	32230	90x55x62
	Honda GX 270 Cod. Motore 4925 ⑩ ⑮	-	-	8,4	6,3	⑫	32231	90x55x62
	Lombardini 15LD 350 Cod. Motore 4786 ⑩ ⑮	7,5	5,5	-	-	⑫	32232	90x55x62

AR 713 S GCI VDR 50 I - Honda GX340 HP 10,7  
con CR cod. 1639

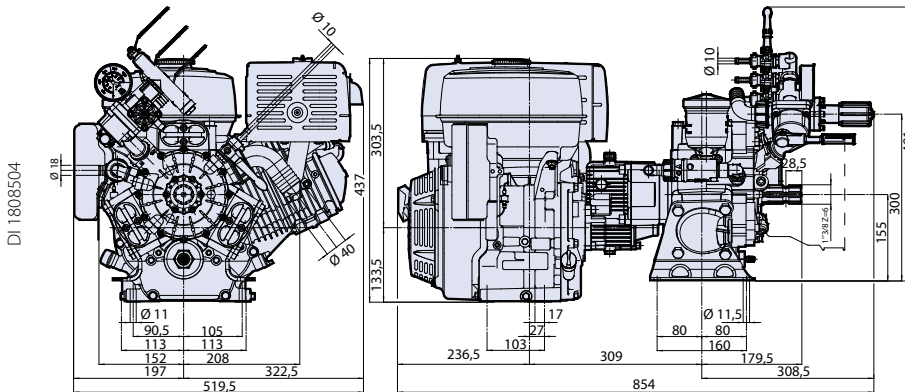

AR 813 SD GCI VDR 50 I - Lombardini 15D 500 HP 12  
con CR cod. 1639

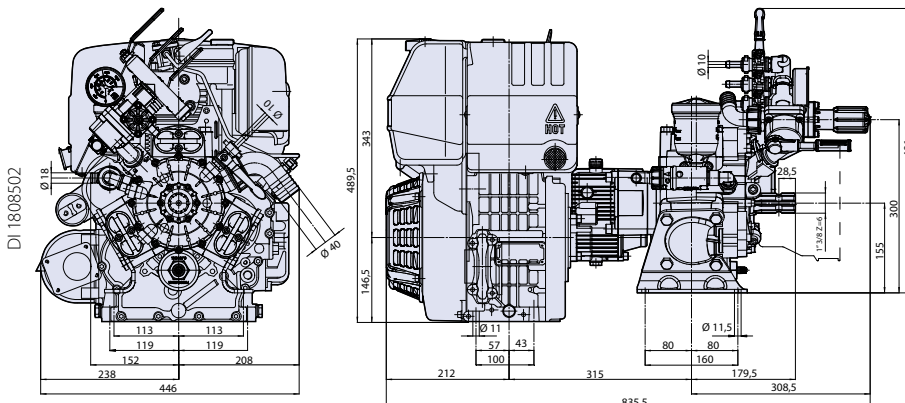

- ⑩ Auto-avvolgente incorporato • Built-in recoil.
- ⑫ Solo base motore • Motor base only.
- ⑭ Con avviamento elettrico di serie • With electric start standard.
- ⑮ A richiesta avviamento elettrico e quadro per motori a 4 tempi • Supplement for electric starting and panel for 4-stroke engines
- ⑯ Con base • With base
- ⑰ Motore senza serbatoio carburante • Engine without fuel tank
- ⑱ A richiesta marmitta std (precisare se dx o sx) • Standard silencer available on request (specify right or left)

# Gruppi Motopompa

## Motor-driven pump assemblies



Versioni Versions	Tipo pompa Pump type	Marca e tipo di motore Motor make and type	Max Power		Net Power		Base Base	Codice Code	Dim. scatola Box dimensions LxWxH (cm)
			HP	Kw	HP	Kw			

### S - SD

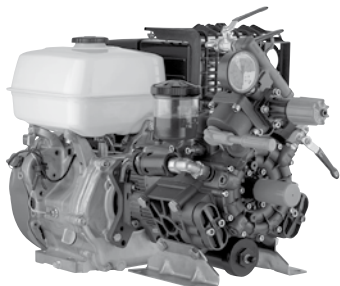

<b>AR 713</b>	Rato EHR 420 Cod. Motore 44915 ⑩ ⑮	14	10,3	-	-	⑫	32234	90x55x62
	Honda GX 340 Cod. Motore 4926 ⑩ ⑮	-	-	10,7	8	⑫	32235	90x55x62
	Lombardini 15LD 500(Ø1") Cod. Motore 44004 ⑩ ⑮	12	8,8	-	-	⑫	32236	90x55x62
<b>VDR 50 I</b>								

<b>AR 813</b>	Rato EHR 420 Cod. Motore 44915 ⑩ ⑮	14	10,3	-	-	⑫	32238	90x55x62
	Subaru EX 40 Cod. Motore 44324 ⑩ ⑮	-	-	14	10,3	⑫	32239	90x55x62
	Honda GX 390 Cod. Motore 4554 ⑩ ⑮	-	-	11,7	8,7	⑫	32240	90x55x62
	Lombardini 15LD 500(Ø1") Cod. Motore 44004 ⑩ ⑮	12	8,8	-	-	⑫	663	90x55x62
<b>VDR 50 I</b>								

### S



<b>AR 1064</b>	B&S Vanguard18 Cod. Motore 4924 ⑭	18	13,4	-	-	⑫	32243	90x55x62
	Subaru EH 65 Cod. Motore 44709 ⑭ ⑳	-	-	18	13,4	⑫	32243	90x55x62
	Honda GX 630R-QXF Cod. Motore 4019 ⑭ ⑳ ㉑	-	-	20,8	15,5	⑫	32244	90x55x62
<b>VDR 50 I</b>								

<b>AR 45bp</b>	Rato EHR 160 Cod. Motore 44906 ⑩	5,5	4,1	-	-	⑫	32260	90x55x62
	Honda GP 160 Cod. Motore 44804 ⑩	-	-	4,8	3,6	⑫	32264	90x55x62
<b>G.C.I.</b>								



<b>AR 80bp</b>	Subaru EX 17 Cod. Motore 44608 ⑩ ⑮	5,7	4,2	-	-	⑫	32247	90x55x62
	Honda GX 160 Cod. Motore 44803 ⑩ ⑮	-	-	4,8	3,6	⑫	32248	90x55x62
<b>G.C.I.</b>								



<b>AR 135bp</b>	B&S Vanguard 6,5 (Max 10 bar) Cod. Motore 4523 ⑩ ⑮	6,5	4,7	-	-	⑫	32251	90x55x62
	Honda GX 270 Cod. Motore 4925 ⑩ ⑮	-	-	8,4	6,3	⑫	32252	90x55x62
<b>S.G.C.</b>								

<b>AR 140bp</b>	Subaru EX 17 (Max 15 bar) Cod. Motore 44688 ⑩ ⑮	9	6,7	-	-	⑫	32254	90x55x62
<b>S.G.C.</b>								

Il presente catalogo annulla e sostituisce tutti i precedenti, può essere modificato senza alcun preavviso.

La Annovi Reverberi S.p.A. si riserva la facoltà di effettuare consegne parziali. Dati, descrizioni ed illustrazioni sono forniti a titolo indicativo e non impegnativo.

This catalogue cancels all previous ones and can be modified without notice. Annovi Reverberi S.p.A. preserves the right to carry out partial shipments. Characteristics and descriptions are not binding.





**ANNOVI  
REVERBERI** ®  
The Power of Experience



Reg. N. 028A  
UNI EN ISO 9001:2008

**Annovi Reverberi spa**

Agriculture & Industry Division  
Via Martin L. King 3  
41122 Modena (Italy)  
Tel +39 059 414 411  
Fax +39 059 253 505  
infoar@annovireverberi.it  
www.annovireverberi.it

Cleaning Division  
Via Aldo Moro 40  
41030 Bomporto, Mo (Italy)  
Tel +39 059 8199 011  
Fax +39 059 8199 000  
info@arblueclean.it  
www.arblueclean.it

Member of



**AR North America Inc.**

140 - 81st Avenue Northeast  
Fridley, MN USA 55432  
Ph. 001 763 398 2008  
Fax 001 763 398 2009  
www.arnorthamerica.com

**AR China Distribution Co. Ltd**

2nd Floor, Building 1, No. 651 Jiangting Rd.  
Jinhui Town, Fengxian District, Shanghai  
201404 China  
Ph. +86 21 54846800  
Fax +86 21 54846800 ext 815  
info@ar-china.cn  
www.ar-china.cn