



**ANNOVI
REVERBERI**
The Power of Experience

Un supermercato di Parigi, un autolavaggio di Los Angeles, un campo di grano a sud di Kiev: un'unica cosa in comune, un prodotto che deriva dal cuore dell'Italia, una pompa Annovi Reverberi.

Fondata nel 1958 da Corrado Reverberi, Annovi Reverberi è ancora oggi un'azienda italiana di famiglia, una realtà metalmeccanica fortemente legata al territorio, fatta di persone idee e progetti innovativi. Un esempio di imprenditoria italiana basata su esperienza, artigianalità e innovazione. Un marchio riconosciuto in tutto il mondo come simbolo di massima qualità e saper fare italiano. 60 anni di storia che hanno visto il gruppo Annovi Reverberi crescere notevolmente e diventare protagonista in tre settori di riferimento: agricoltura con la produzione di pompe a membrana; industria attraverso il successo delle pompe a pistoni AR e infine intorno agli anni '90 cleaning con lo sviluppo di idropulitrici e aspiratori.

A supermarket in Paris, a car wash in Los Angeles, a wheat field south of Kiev: the same thing in common; a product from the heart of Italy, an Annovi Reverberi pump. Founded in 1958 by Corrado Reverberi, Annovi Reverberi is still an Italian family-owned company, a mechanical engineering reality strongly linked to the territory and made up of people, ideas and innovative projects. An example of Italian entrepreneurship based on experience, innovation and passion. A brand recognized all over the world as a symbol of top quality and Italian know-how. It's a 60 year history that has seen the Annovi Reverberi group grow considerably and become a protagonist in three sectors of reference: agriculture with the production of diaphragm pumps; industry through the success of AR piston pumps and, finally, around the 90s, cleaning with the development of high-pressure washers and vacuum cleaners.

INDUSTRIAL DIVISION

Annovi Reverberi, leader nella personalizzazione di prodotto, negli anni è stata in grado di adattarsi alle richieste del singolo cliente sviluppando oltre 50 tipologie di pompe a pistoni.

Ogni singolo prodotto marchiato AR viene realizzato seguendo processi produttivi che rispettano la norma ISO 9001:2015 e viene collaudato prima dell'invio al cliente.

Scegliere Annovi Reverberi significa affidarsi ad un marchio che è stato capace di affermare la propria credibilità nel corso del tempo. Con oltre il 75% del fatturato della divisione industria del Gruppo che deriva da esportazioni extra-UE oggi lo scudo AR è simbolo di tecnologia italiana in tutto il mondo.

Nata a Modena

Born in Modena

Annovi Reverberi, leader in product personalization, over the years has been able to adapt its products to the needs of individual customers by developing over 50 types of piston pumps.

Every single AR branded product is created following production processes that comply with the ISO 9001: 2015 standard and is tested before being sent to the customer. Choosing Annovi Reverberi means relying on a brand that has been able to evolve and develop over time. Over 75% of AR's Industrial Division Sales turnover derives from exports outside the EU. Today the AR logo is a symbol of Italian technology all over the world.

**SCAN
ME!**



industry.annovireverberi.it

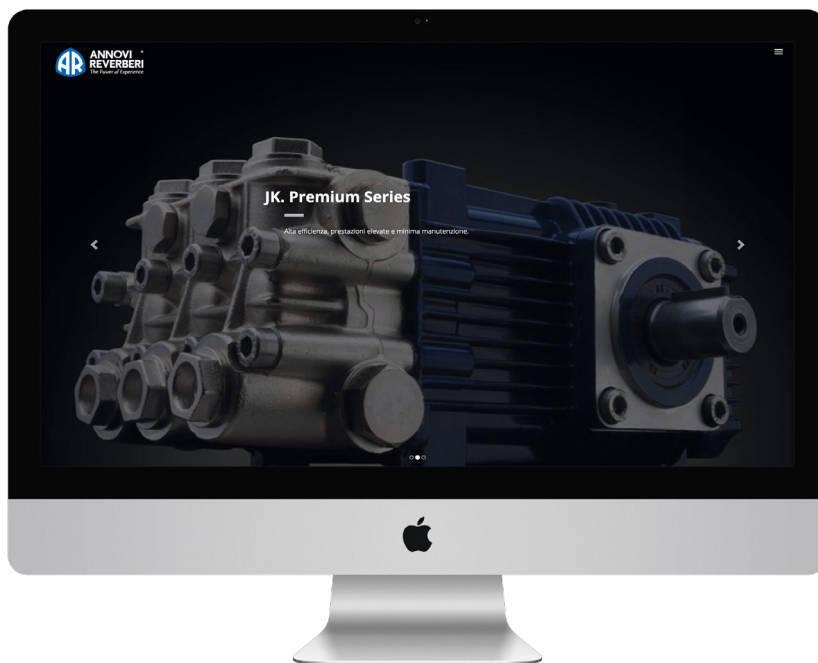

WEB 2.0

Il viaggio all'interno del mondo Annovi Reverberi continua sul nostro nuovo sito **www.annovireverberi.it**. Nuova veste grafica, maggiori contenuti, interattività e novità aziendali sempre in prima linea: sono questi alcuni degli ingredienti che caratterizzano il remake del sito. Non solo prodotto quindi ma anche appuntamenti fieristici, rassegna stampa ed i tanti progetti che a breve vedranno la luce.

WEB 2.0

*The journey through the world of Annovi Reverberi continues on our new website **www.annovireverberi.it**. New graphics, more contents, interactivity and a strong focus on the latest company news: these are amongst the ingredients of the site's remake. So not just products but also exhibition dates, press review and lots of upcoming projects.*



PLUS

Testa pompa in ottone forgiato con disegno per alta resistenza.

Forged brass pump head, designed for strength.

Valvole di aspirazione e mandata con passaggi acqua maggiorati.

Intake and delivery valves with larger water passages.

Pistoni in ceramica di grosso spessore per una maggiore durata.

Extra-thick ceramic pistons for greater durability.

Sistema di tenuta a doppia guarnizione.

Double gasket sealing system.

Anelli tenuta olio con doppio labbro.

Double lip oil seals.

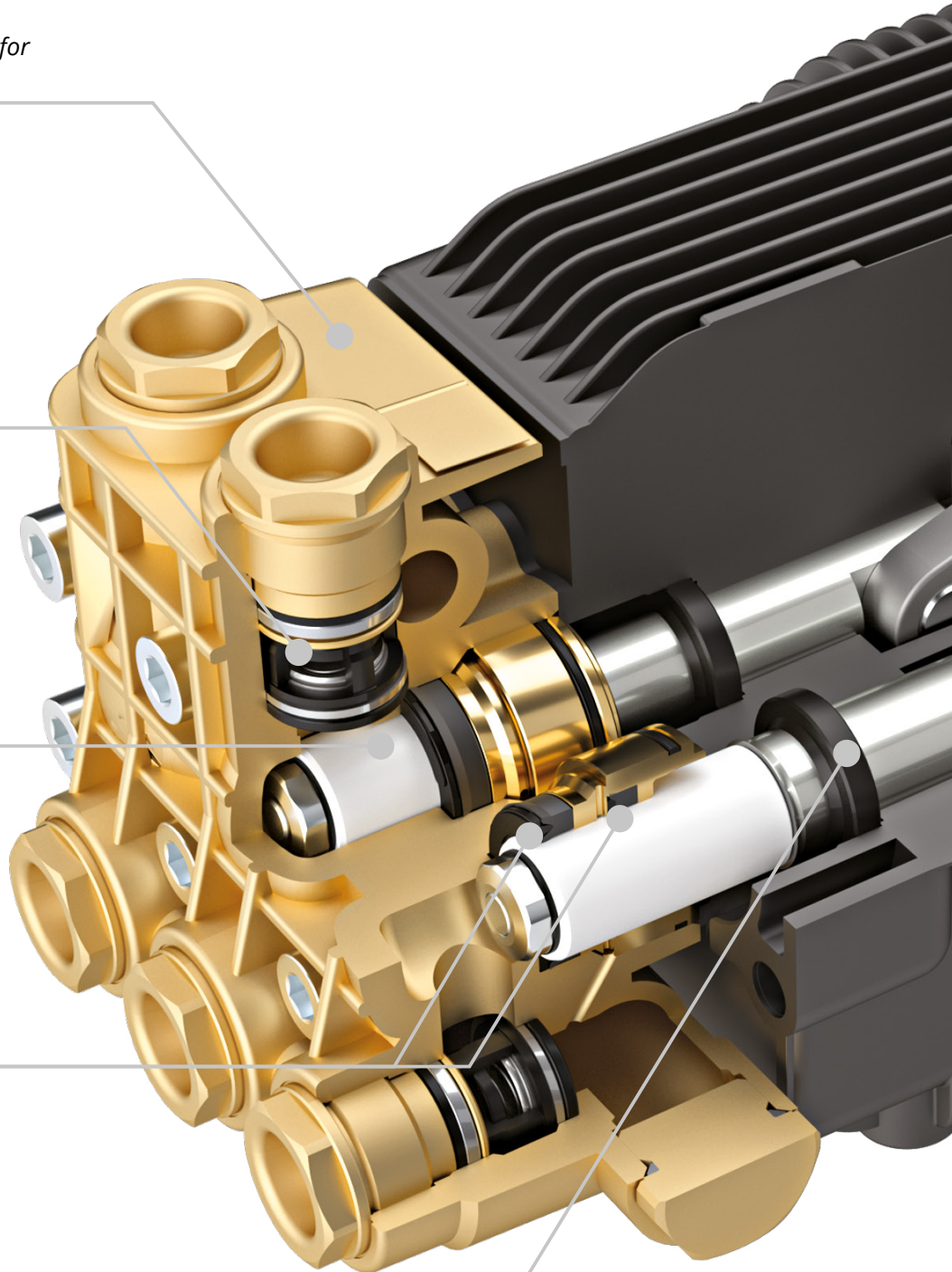

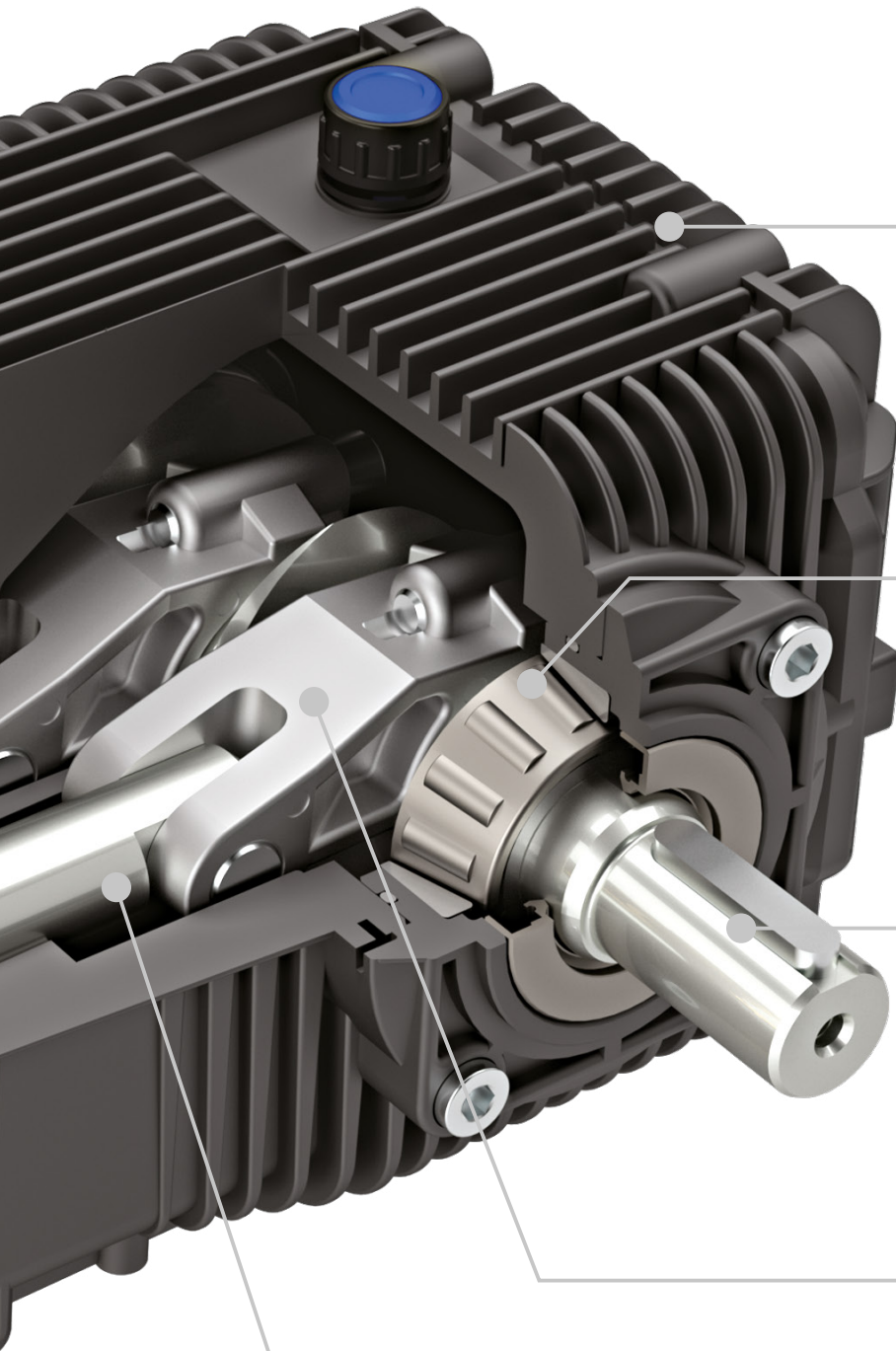

Corpo pompa di disegno robusto e con elevata alettatura per un miglior smaltimento del calore.
Ruggedly designed pump body with deep fins for better cooling.

Cuscinetti a rulli conici di qualità e sovradimensionati.
Top quality, oversized tapered roller bearings.

Albero sovradimensionato e con terminale lungo per una migliore trasmissione della coppia.
Oversized shaft with long end section for better torque transmission.

Bielle sovradimensionate e realizzate con una speciale lega antifrizione. Scomponibili in due parti per una migliore manutenzione.
Oversized connecting-rods in a special low-friction alloy. Split into two parts for easier maintenance.

Pistoni di guida sovradimensionati e rettificati per una riduzione dell'attrito durante lo scorrimento ed una migliore tenuta olio.
Oversized, piston guides for smoother stroke and better oil seal performance.

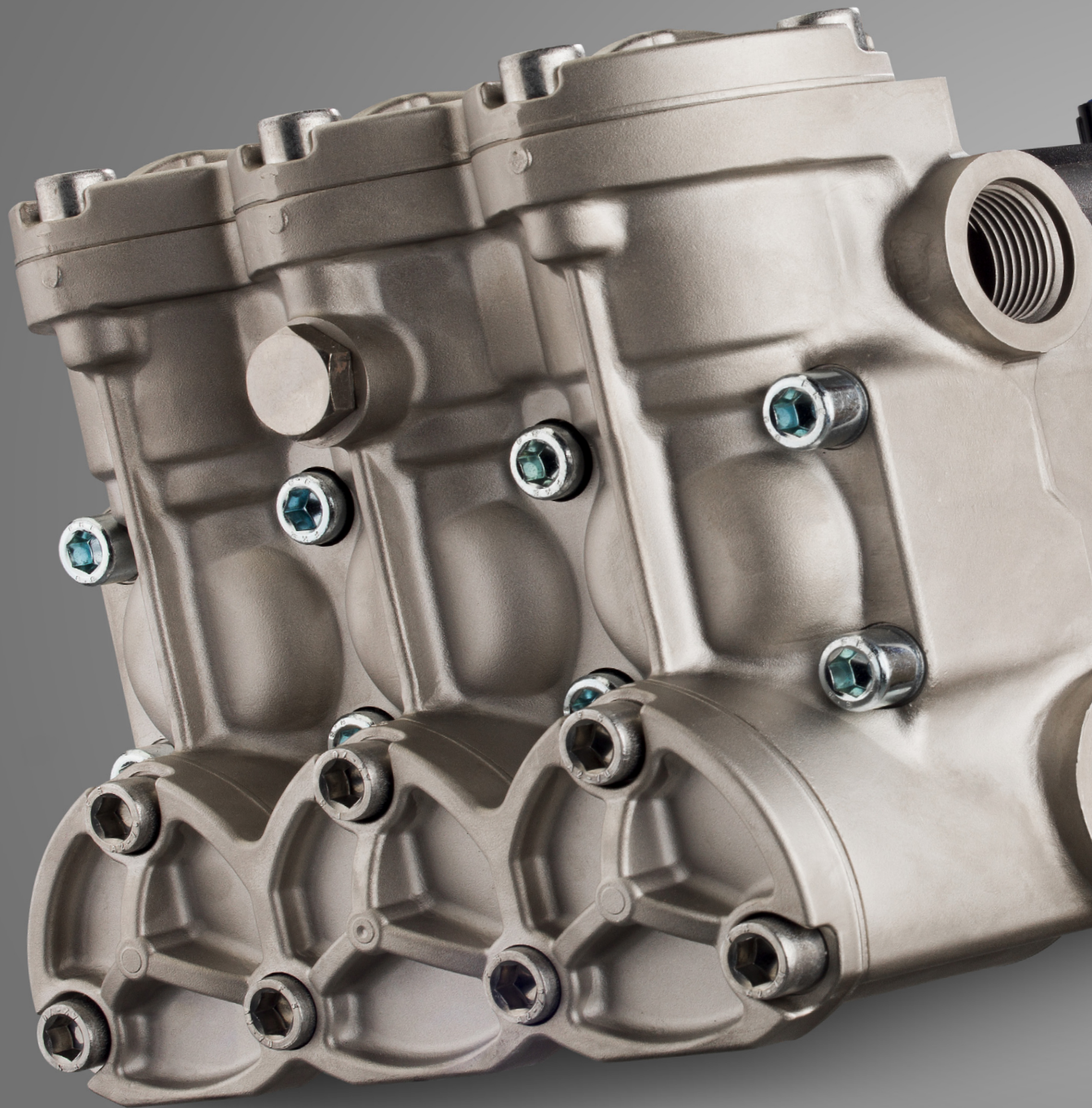

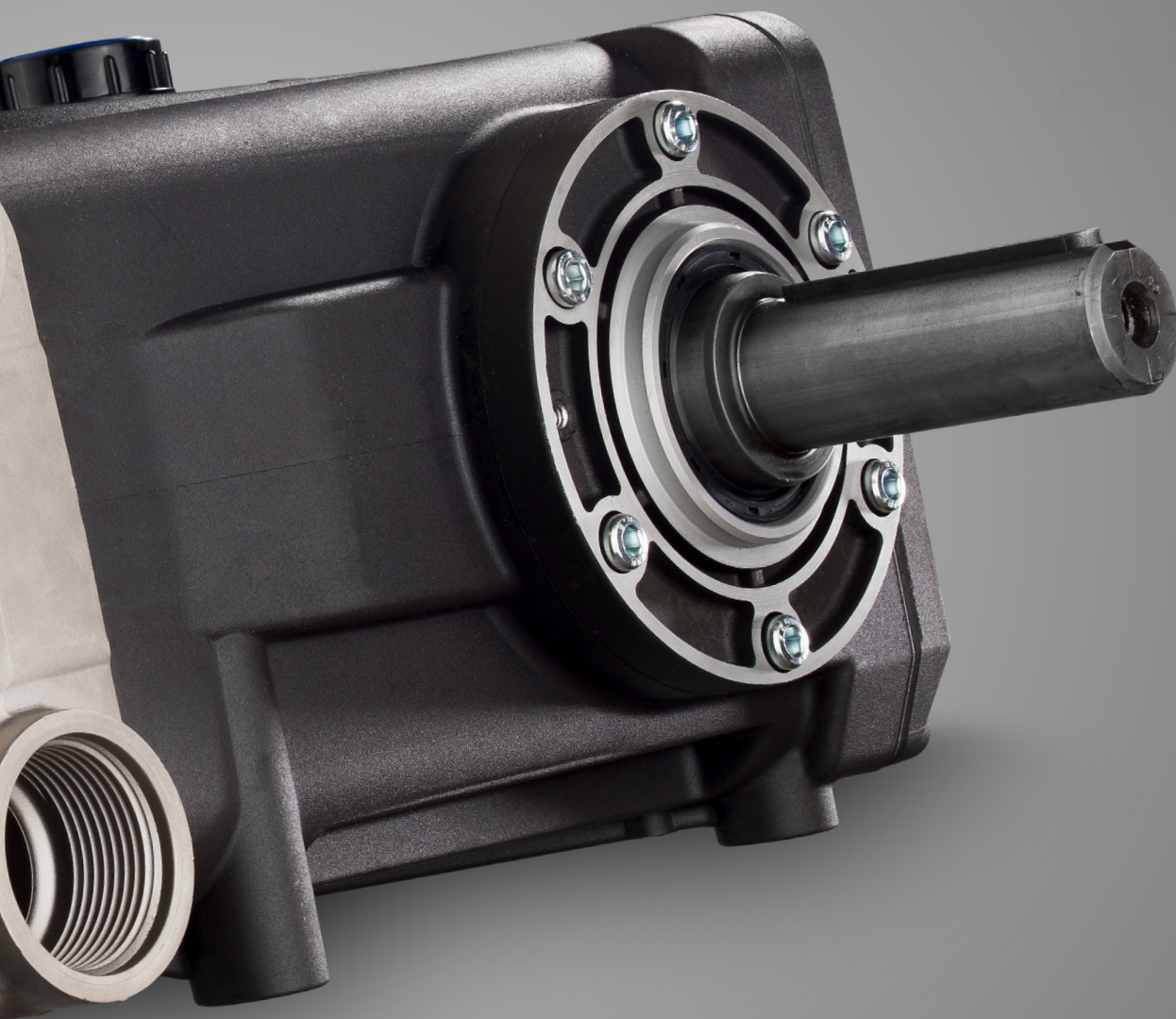

**PER OGNI INDUSTRIA LA SUA
POMPA A PISTONI**

L'attenzione per il dettaglio e componenti di altissima qualità lavorati direttamente in azienda sono stati gli ingredienti principali per sviluppare una gamma completa di pompe a pistoni caratterizzate da diverse prestazioni tecniche per garantire non solo il lavaggio ad acqua ma anche nuove applicazioni come, ad esempio, misting, osmosi inversa e abbattimento polveri.

Le pompe a pistoni AR sono compatte, sempre più silenziose, dotate di pistoni in ceramica per garantire una maggiore durata e necessitano una manutenzione minima data la loro affidabilità. Inoltre possono essere associate a diversi accessori e allestite con motori idraulici, a scoppio e elettrici tra cui i motori Made in Italy Ravel, azienda parte del gruppo.

**FOR EVERY INDUSTRY THE PISTON PUMP
YOU NEED**

The attention to detail and high quality components finished directly inside the company have been the main factors in developing a full range of piston pumps characterized by different technical characteristics suitable not only for cleaning but also for new applications such as misting, reverse osmosis and dust suppression.

AR piston pumps are compact, silent running, equipped with ceramic pistons to guarantee longer life and require minimal maintenance due to their reliability.

In addition, AR pumps can be associated with various accessories and equipped with hydraulic, petrol and electric engines including the Made in Italy Ravel electric motors, manufactured in a company belonging to the Group.



INDICE INDEX

Indice / Index

276 SERIES	P 18
414 SERIES	P 26
320 SERIES	P 34
132 SERIES	P 40
178 SERIES	P 46
322 SERIES	P 58
228 SERIES	P 64
402 SERIES	P 80
298 SERIES	P 84
194 SERIES	P 90
366 SERIES	P 108
418 SERIES	P 118
282 SERIES	P 120
STAINLESS STEEL	P 124
ADDITIONAL ELECTRIC MOTOR	P 132
WOBBLE PLATE	P 138

<u>Accessori Accessories</u>	P 150
------------------------------	-------



Series	Model	Factory	Lawnmower	Forklift	Conveyor	Gear	Tractor	Forklift	Truck	Pallet	Worker	Crane	Ship	Spray nozzle	PAG.
276 Series															18
	RS		●												
	RSS		●												
	RSV		●												
	HRS		●												
414 Series															26
	JR		●												
	JRA		●												
	JRS		●												
	JRV		●												
	JR-M									●					
	JRA-M									●					
	HJR		●												
	HJRS		●												
	HJR-M									●					
320 Series															34
	RC		●												
	RCA		●												
	RCS		●												
	RCV		●												
	HRC		●												
	RC-M									●					
	RCA-M									●					
132 Series															40
	XT		●												
	XTS		●												
	XTA		●												
	XTV		●												
	HXT		●												
178 Series															46
	XM		●												
	SXM		●												
	XMA		●												
	SXMA		●												
	XMS		●												
	SXMS		●												
	XMV		●												
	SXMV		●												
	XM-M									●					
	XHW				●				●		●				
	HXM-HSXM		●												
	XM+F38								●						
	HYD-XM								●						
322 Series															58
	RR		●	●	●		●					●			
	RRA		●	●	●		●					●			
	RRV		●	●	●		●					●			
	HRR		●	●	●		●					●			
228 Series															64
	RK		●	●	●		●		●			●		●	
	RKA		●	●	●		●		●			●		●	
	RKV		●	●	●		●		●			●		●	
	JK		●	●	●		●		●			●		●	
	JKA		●	●	●		●		●			●		●	
	RHW				●				●						
	RCW		●	●	●		●					●			
	HRK		●	●	●		●					●			
	RK+F38								●						
	HYD-RK								●						
402 Series															80
	RG	●	●	●	●		●					●		●	
	RGA	●	●	●	●		●					●		●	
	RGX	●	●	●	●		●		●			●		●	
	RGXA	●	●	●	●		●		●			●		●	
298 Series															84
	RW	●	●	●	●	●	●		●	●	●	●		●	
	RWA	●	●	●	●	●	●		●	●	●	●		●	
	HRW	●	●	●	●	●	●		●	●	●	●		●	



Model	Factory	Tractor	Forklift	Pallet Jack	Gear	Tractor	Forklift	Truck	Pallet Jack	Worker	Forklift	Ship	Spray Gun	PAG.
194 Series														90
XWF	●		●	●	●	●		●	●	●	●			●
XW	●	●	●	●	●	●		●	●	●	●			
XWL	●		●	●	●	●		●	●	●	●			
XWT	●		●	●	●	●		●	●	●	●			
XWA	●		●	●	●	●		●	●	●	●			
XWLA	●		●	●	●	●		●	●	●	●			
XWP	●		●	●	●	●		●	●	●	●			
SXW	●	●	●		●	●		●	●	●	●			●
SXWA	●	●	●		●	●		●	●	●	●			●
SHP	●	●	●		●	●		●	●	●	●			●
SHPA	●	●	●		●	●		●	●	●	●			●
STP-I	●	●	●					●	●	●	●	●		
STPA-I	●	●	●					●	●	●	●	●		
CWX				●										
WHW				●				●						
WHWL				●				●						
HXW	●	●	●	●	●	●		●	●	●	●			
HXWL	●	●	●	●	●	●		●	●	●	●			
HXWA	●	●	●	●	●	●		●	●	●	●			
HSXW	●	●	●			●		●	●	●	●			
HSHP	●	●	●			●		●	●	●	●			
HYD-XW/XWL								●						●
XW+F38								●						
366 Series														108
RTX	●		●	●	●	●		●	●	●	●			●
RTX-I	●		●	●	●	●		●	●	●	●	●		
HRTX	●		●	●	●	●		●	●	●	●	●		
HYD-RTX								●						●
418 Series														118
RTD	●		●	●	●	●		●	●	●	●			●
RTD-L	●		●	●	●	●		●	●	●	●			●
282 Series														120
RTP	●							●		●	●			●
RTJ	●		●					●		●	●			●
RTF	●			●				●	●					●
Stainless steel														124
XM-SS								●						●
XMA-SS								●						●
RK-SS								●						●
HYD RK-SS								●						●
RKA-SS								●						●
XWL-SS								●						●
RTX-SS								●						●
Additional Electric Motor														132
HPV		●												
HPV-O		●												
HPV-MO									●					
HPE		●												
HPE-M										●				
Wobble plate														138
RPV	●													
RPW	●													
RMV	●													
RMW	●													
RQV	●													
RQW	●													
RXV	●													
XJS	●													
SJS	●													
SJV	●													
HRM-O	●													
HRM-MO	●										●			
HPJ	●													
HYD-XJS									●					
XJS+F39									●					





276 SERIES

RS
RSS
RSV
HRS

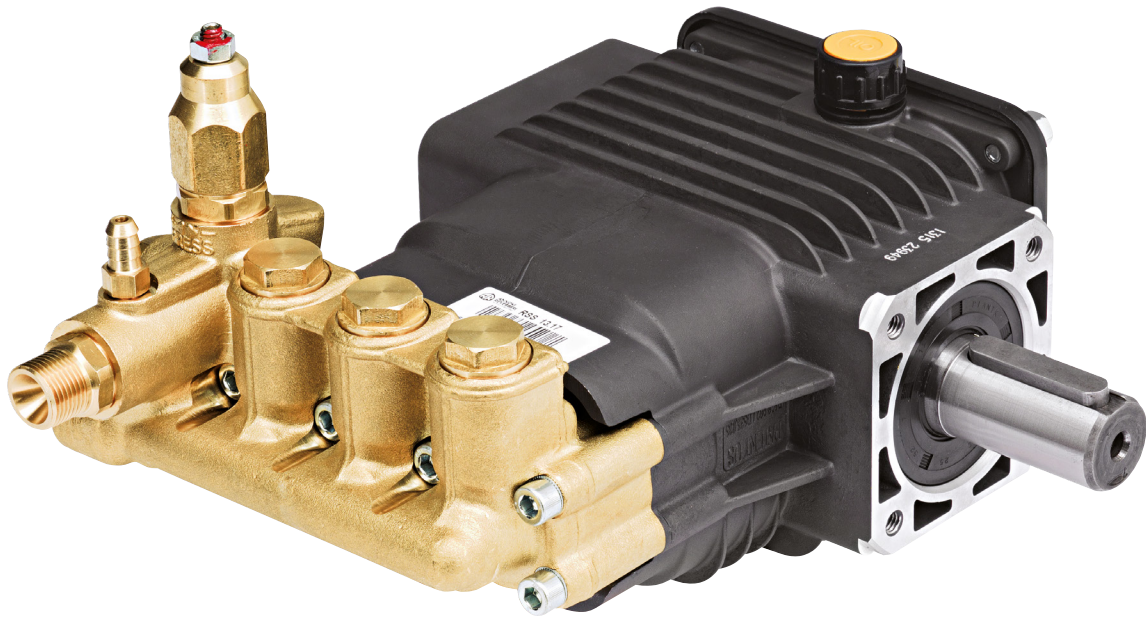

Corpo in alluminio pressofuso.

Coperchio laterale chiuso.

Bielle in lega zinco- alluminio pressofuso oppure in bronzo.

Testa in ottone stampato con valvola di regolazione integrata.

Pistoni acciaio inox con copertura in ceramica.

Pump body in pressure die-cast aluminium alloy.

Closed side cover.

Connecting rods in die-cast zinc-aluminium alloy. Bronze connecting rods available.

Pump head in forged brass with integrated pressure regulating valve.

Pistons in ceramic-coated stainless steel.

276 Series

POMPA ALBERO MASCHIO Solid shaft pump

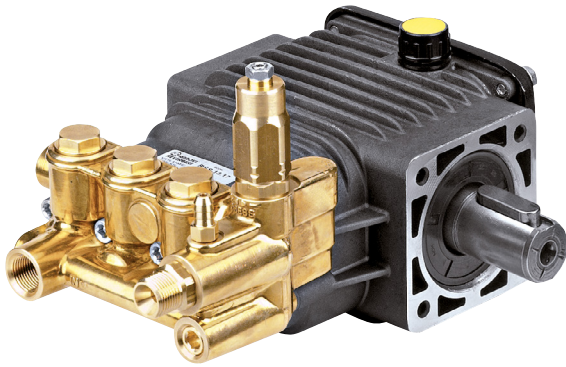

idropultrici
pressure
washers

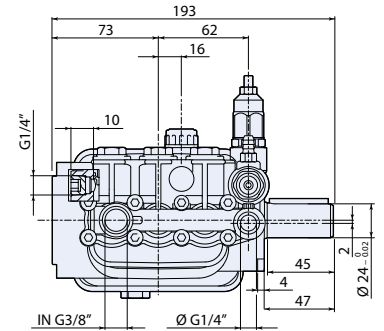
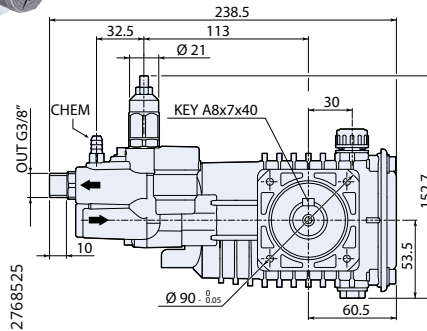

N version

Flangiatura compatibile XT N.
XT N flange type.

MOD	COD	MAX	MAX						
		l/min	gpm	bar	psi	hp	kW	N° giri/1'	kg
RS 1450rpm Nversion Ø24mm									
RS 11.11 N	23084	11	2,90	110	1600	3	2,2	1450	7
RS 11.14 N	24543	11	2,90	140	2000	4	3	1450	7
RS 11.18 N	23616	11	2,90	180	2600	5,5	4	1450	7
RS 13.17 N	23160	13	3,43	170	2500	5,5	4	1450	7
RS 15.15 N	23161	15	3,96	150	2200	5,5	4	1450	7



testa in
ottone
brass
head



bielle in
alluminio
connecting-rods
in aluminium



POMPA ALBERO MASCHIO Solid shaft pump



idropultrici
pressure
washers

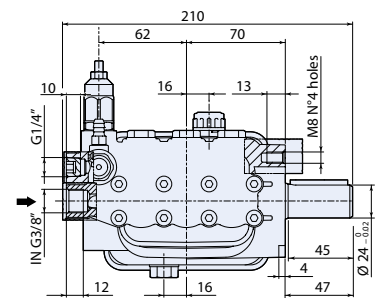
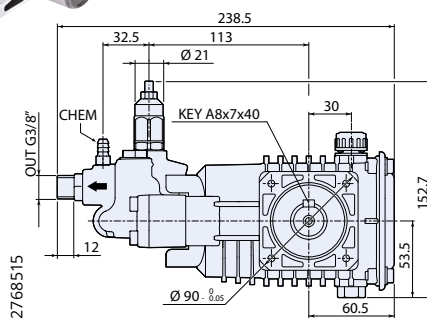

N version

Flangiatura compatibile XT N.
XT N flange type.

MOD	COD	MAX	MAX						
		l/min	gpm	bar	psi	hp	kW	N° giri/1'	kg
RSS 2800rpm Nversion Ø24mm									
RSS 11.14 N	27186	11	2,90	140	2000	4	3	2800	7
RSS 11.18 N	25187	11	2,90	180	2600	5,5	4	2800	7
RSS 13.17 N	23949	13	3,43	170	2500	5,5	4	2800	7
RSS 15.15 N	23182	15	3,96	150	2200	5,5	4	2800	7



testa in
ottone
brass
head



bielle in
alluminio
connecting-rods
in aluminium



276 series

POMPA ALBERO CAVO Hollow shaft pump



idropultrici
pressure
washers

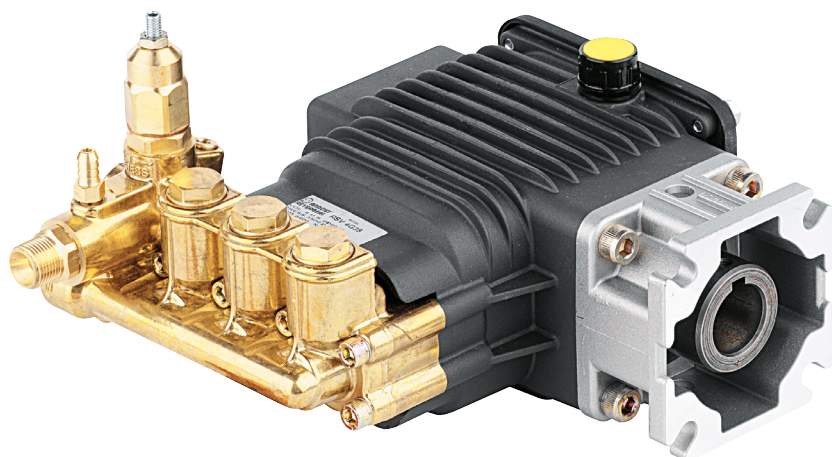

Su richiesta
On request

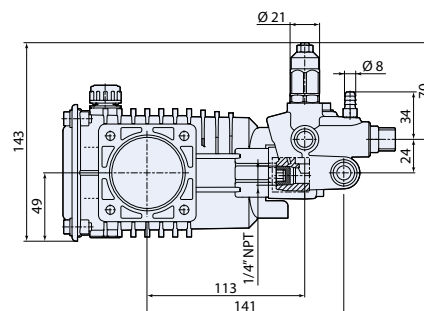
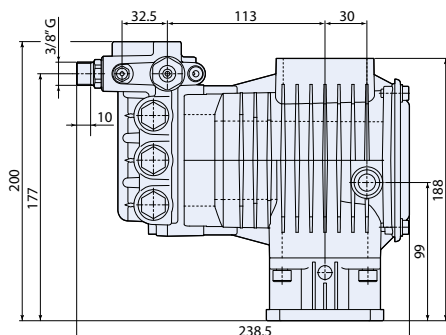
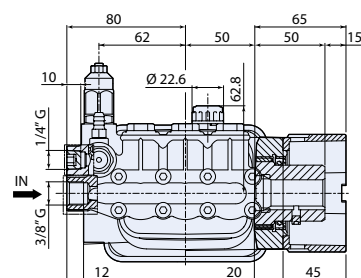
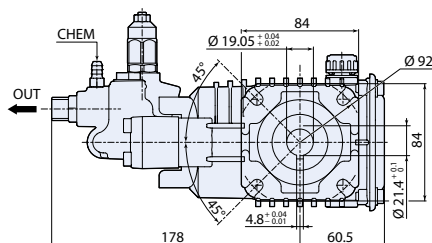

2768501

D version + F25

MOD	COD	MAX	MAX		NET				
		l/min	gpm	bar	psi	hp	kW	N° giri/1'	kg
RSV 3400rpm Dversion + F25 Ø3/4"									
RSV 2.5 G25 D + F25	25918	9,5	2,5	170	2500	4,5	3,3	3400	7
RSV 3 G25 D + F25	23473	11,4	3	170	2500	5	3,7	3400	7

Per motori scoppio flangia Ø3/4" SAE J609a. Flangia inclusa.
For gasoline engine flange Ø3/4" SAE J609a. Flange included.



testa in
ottone
brass
head



bielle in
alluminio
connecting-rods
in aluminium



idropulitrici
pressure
washers

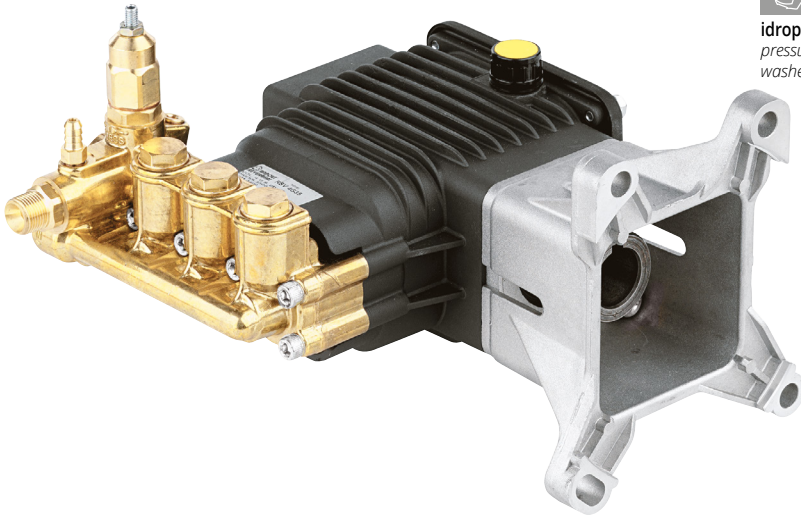

Su richiesta
On request

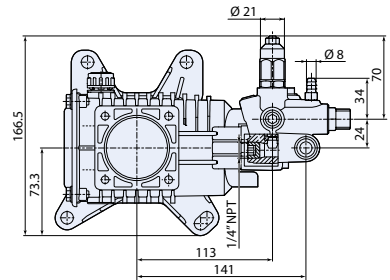
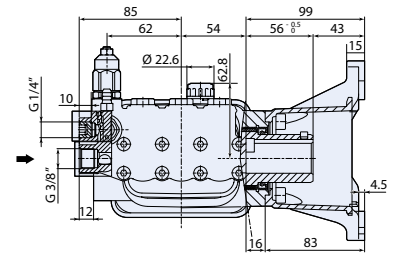
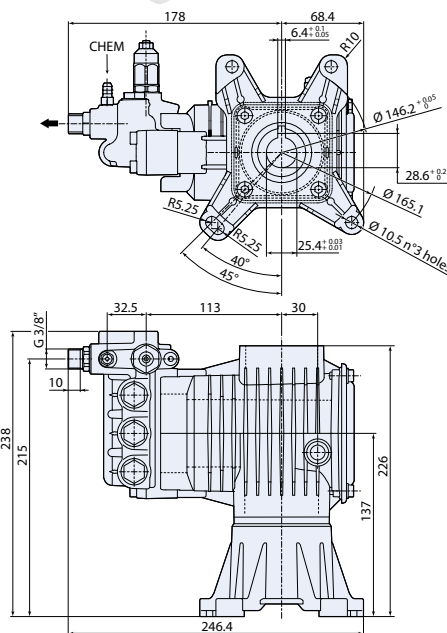

2768500

D version + F40

MOD	COD	MAX	MAX						
		l/min	gpm	bar	psi	hp	kW	N° giri/1'	kg
RSV 3400rpm Dversion + F40 Ø1"									
RSV 3 G30 D + F40	25552	11,4	3	205	3000	5,5	4	3400	7
RSV 3 G35 D + F40	23856	11,4	3	240	3500	7,5	5,5	3400	7,5
RSV 3.5 G35 D + F40	27187	13,2	3,5	240	3500	10	7,5	3400	7,5
RSV 4 G30 D + F40	25795	15,1	4	205	3000	7,5	5,5	3400	7
RSV 4 G35 D + F40	27094	15,1	4	240	3500	10	7,5	3400	7,5
RSV 4 G40 D + F40	24582	15,1	4	275	4000	11	8,2	3400	7,5

Per motori scoppio flangia Ø1" SAE J609a. Flangia inclusa.
For gasoline engine flange Ø1" SAE J609a. Flange included.



testa in
ottone
brass
head



bielle in
bronzo
connecting-rods
in bronze



bielle in
alluminio
connecting-rods
in aluminium



idropultrici
pressure
washers

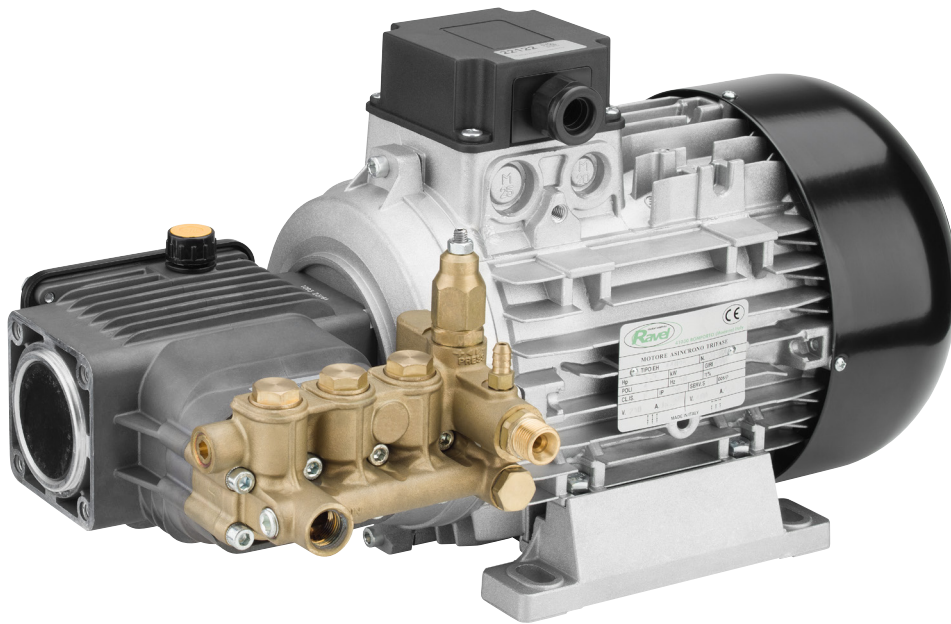

GR. 100 motor hollow shaft

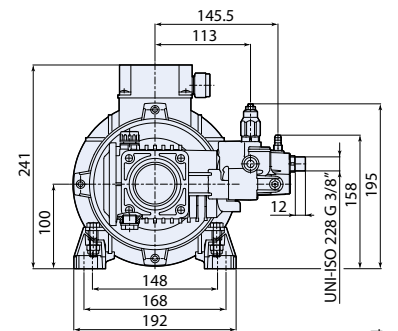
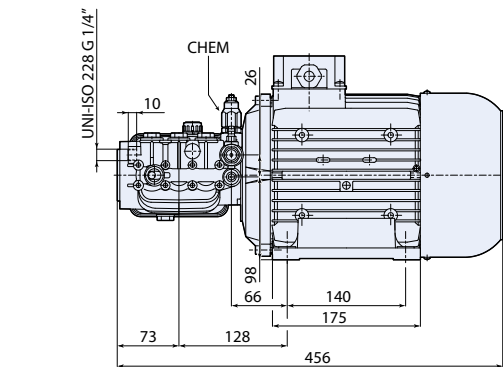

2768514

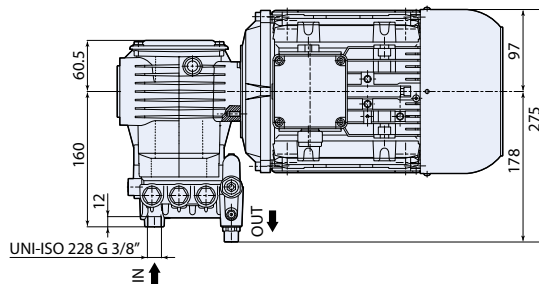

MOD	COD	MAX		MAX				⚡		KG NET			
		1 ~	3 ~	l/min	gpm	bar	psi	hp	kW	N° giri/1'	V 1-50Hz	V 3-50Hz	Gr.
HRS 1450rpm													
HRS 11.11 REG EM	22117	-	11	2,90	110	1600	3	2,2	1450	230	-	100	30
HRS 11.17 REG ET	-	22120	11	2,90	170	2500	5	3,7	1450	-	230/400	100	30
HRS 13.17 REG ET	-	22121	13	3,43	170	2500	5,5	4	1450	-	230/400	100	30
HRS 15.15 REG ET	-	22122	15	3,96	150	2200	5,5	4	1450	-	230/400	100	30



testa in
ottone
brass
head



bielle in
alluminio
connecting-rods
in aluminium



1~50Hz
frequenza
motore
motor
frequency



3~50Hz
frequenza
motore
motor
frequency



JR
JRA
JRS
JRV
JR-M
JRA-M
HJR
HJRS
HJR-M

NEW

414 SERIES

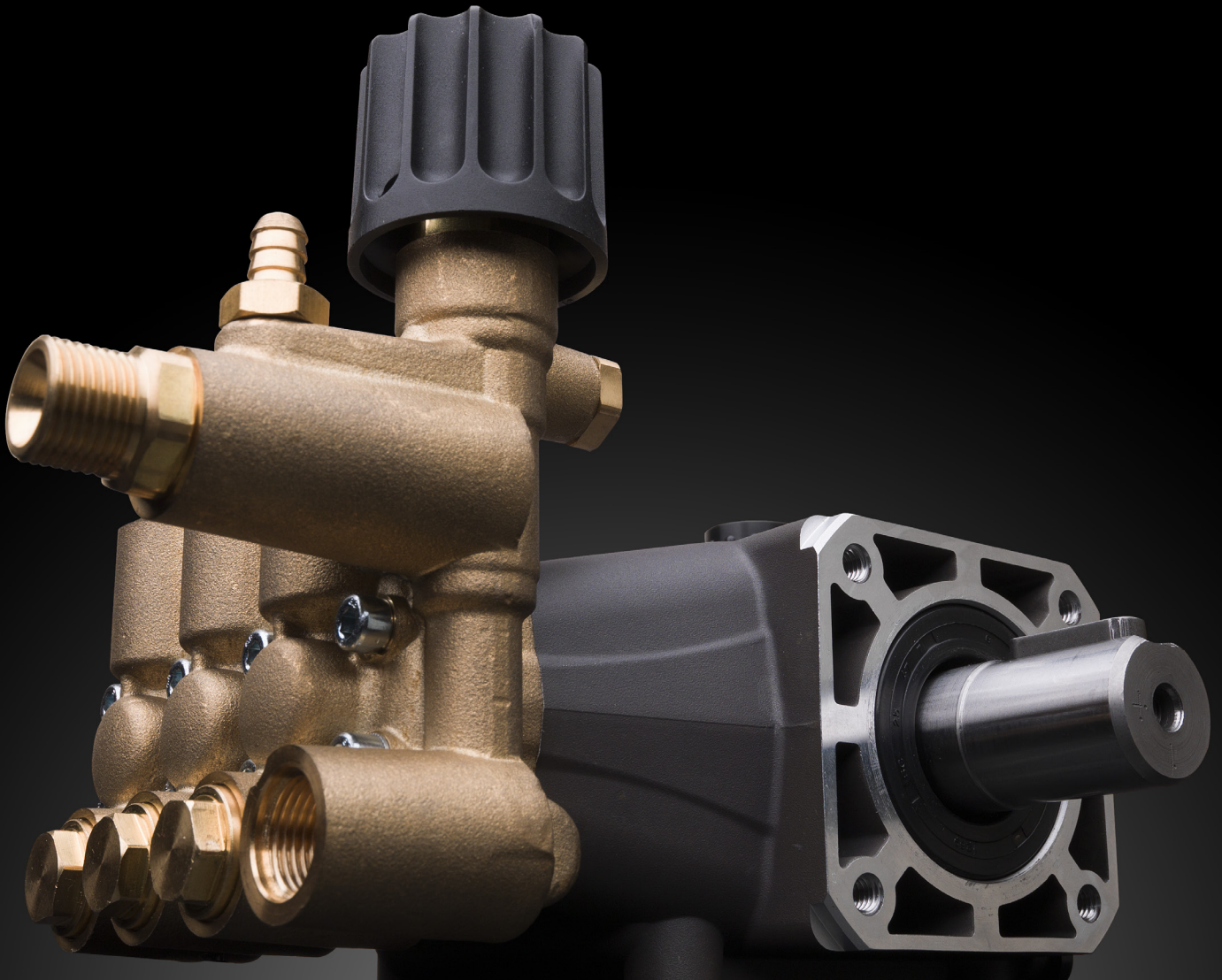

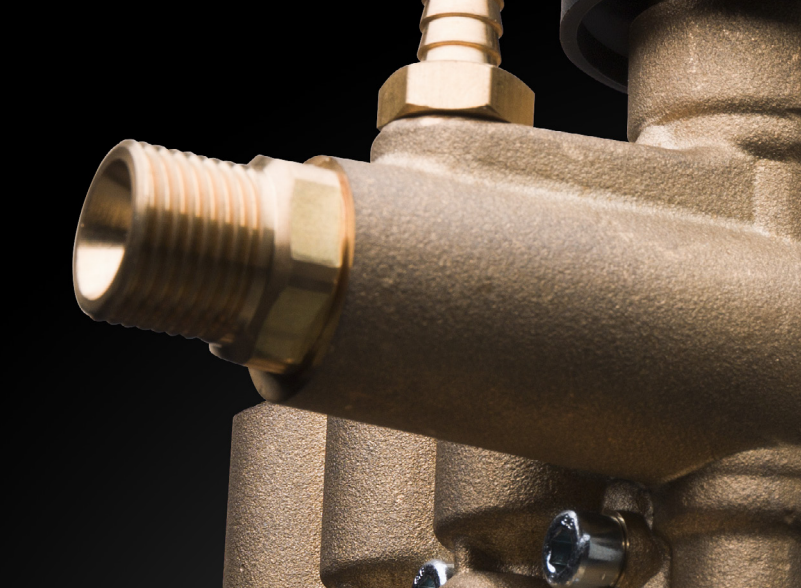

DESIGN FOR PERFORMANCE

CORPO COMPATTO. PRESTAZIONI ELEVATE.

Una gamma completa di pompe a pistoni per garantire diverse applicazioni: JR, JRA, JRS ideali per l'utilizzo su idropultrici grazie alla loro dimensione compatta.

JR-M, JRA-M studiate appositamente per l'applicazione misting.

Disponibile la versione con TSS integrato e in associazione a motori elettrici.

COMPACT BODY HIGH-PERFORMANCE PUMP

A full range of performance piston pumps for different applications: JR, JRA, JRS perfect for high-pressure washers because of its compact dimensions.

JR-M, JRA-M studied in detail for misting application.

Available TSS version and electric motor-pump units.



414 SERIES

JR
JRA
JRS
JRV
JR-M
JRA-M

HJR
HJRS
HJR-M

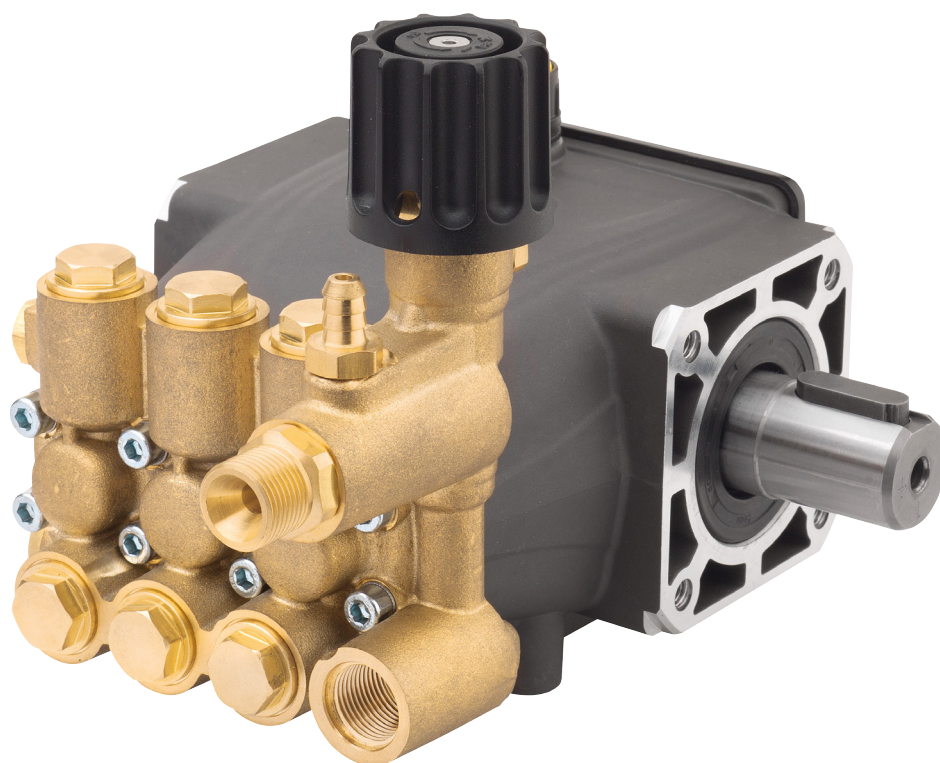

Corpo in alluminio pressofuso.

Coperchio laterale chiuso o con livello olio.

Bielle in lega zinco- alluminio pressofuso.

Testa in ottone stampato con valvola di regolazione integrata.

Pistoni acciaio inox con copertura in ceramica.

Pump body in pressure die-cast aluminium alloy.

Side cover closed or incorporated with oil sight glass.

Connecting rods in die-cast zinc-aluminium alloy.

Pump head in forged brass with integrated pressure regulating valve.

Pistons in ceramic-coated stainless steel.

414 Series

POMPA ALBERO MASCHIO
Solid shaft pump



idropultrici
pressure
washers

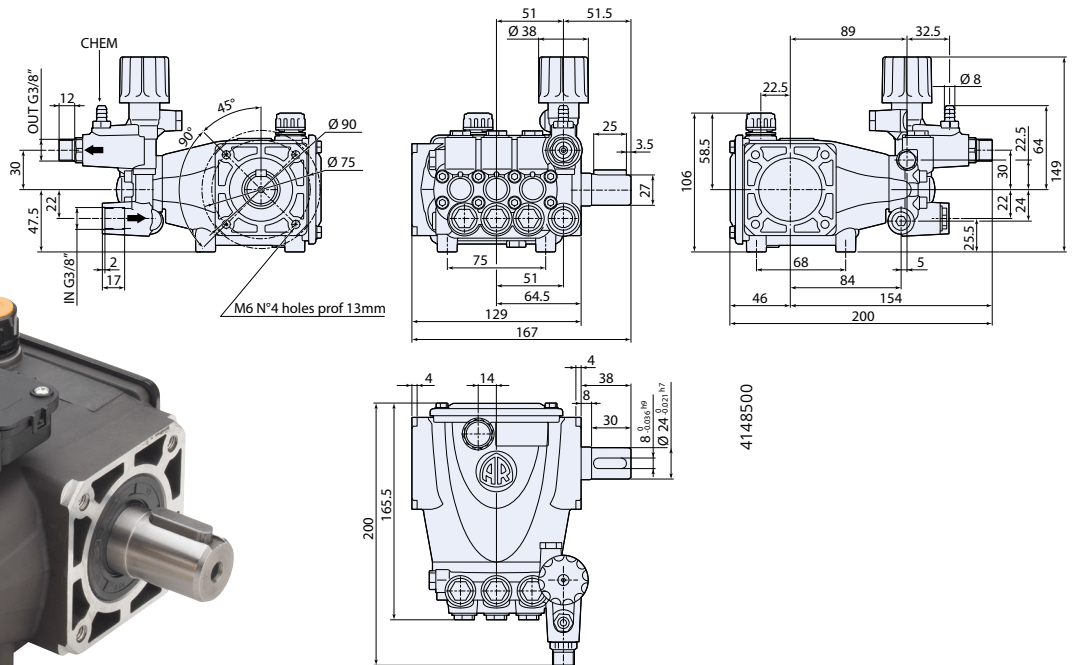

41148500



TSS version

N version

Flangiatura compatibile XT N.
XT N flange type.

MOD	COD	MAX	MAX		NET				
		l/min	gpm	bar	psi	hp	kW	N° giri/1'	kg
JR 1450rpm Nversion Ø24mm									
JR 8.15 N	26438	8	2,11	150	2200	3	2,2	1450	4
JR 8.15 N TSS	26873	8	2,11	150	2200	3	2,2	1450	4
JRA 1750rpm Nversion Ø24mm									
JRA 2.5G22 N	26439	9,5	2,5	150	2200	3,4	2,5	1750	4
JRS 2800rpm Nversion Ø24mm									
JRS 8.15 N	25945	8	2,11	150	2200	3	2,2	2800	4
JRS 8.15 N TSS	26874	8	2,11	150	2200	3	2,2	2800	4
JRS 10.12 N	25944	10	2,64	120	1740	3	2,2	2800	4
JRS 10.15 N	25961	10	2,64	150	2200	4	3	2800	4
JRS 10.15 N TSS	26177	10	2,64	150	2200	4	3	2800	4
JRS 14.15 N	26441	14	3,7	150	2200	5,25	3,9	2800	4

NEW



testa in
ottone
brass
head



bielle in
alluminio
connecting-rods
in aluminium

TSS®
Total Stop
SYSTEM



414 Series

ELECTRIC MOTOR-PUMP UNITS



idropultrici
pressure
washers

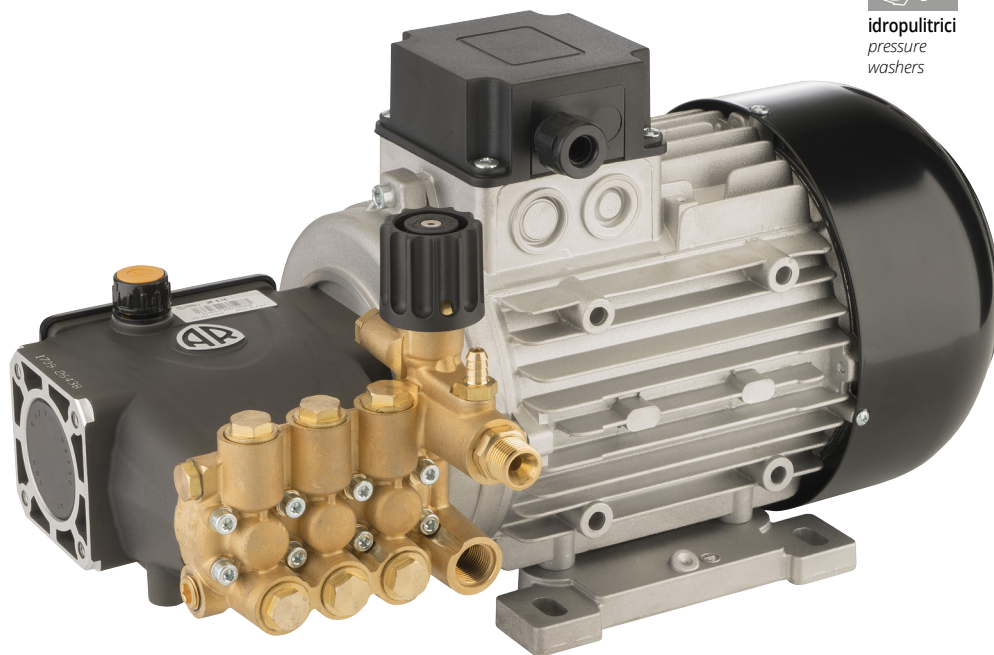

GR. 90 motor hollow shaft

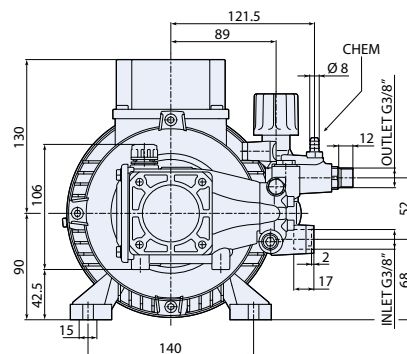
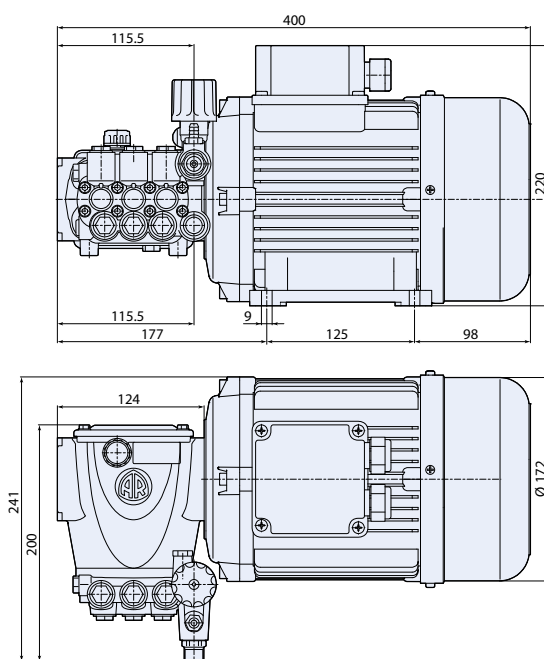

4148509

MOD	COD	MAX		MAX								Gr.	kg
		l/min	gpm	bar	psi	hp	kW	N° giri/1'	V 1-50Hz	V 3-50Hz			
HJR 1450rpm													
HJR 8.15 EM	26890	-	8	2,11	150	2200	3	2,2	1450	230	-	90	19
HJR 8.15 ET	-	26891	8	2,11	150	2200	3	2,2	1450	-	230/400	90	19
HJRS 2800rpm													
HJRS 8.15 EM	26892	-	8	2,11	150	2200	3	2,2	2800	230	-	90	19
HJRS 10.12 EM	26893	-	10	2,69	120	1740	3	2,2	2800	-	230/400	90	19
HJRS 10.12 ET	-	26894	10	2,69	120	1740	3	2,2	2800	230	-	90	19
HJRS 10.15 ET	-	26895	10	2,69	150	2200	4	3	2800	-	230/400	90	20
HJRS 14.15 ET	-	26896	14	3,7	150	2200	5	3,7	2800	-	230/400	90	21

NEW



testa in
ottone
brass
head



bielle in
alluminio
connecting-rods
in aluminium



1~50Hz
frequenza
motore
motor
frequency



3~50Hz
frequenza
motore
motor
frequency



idropulitrici
pressure
washers

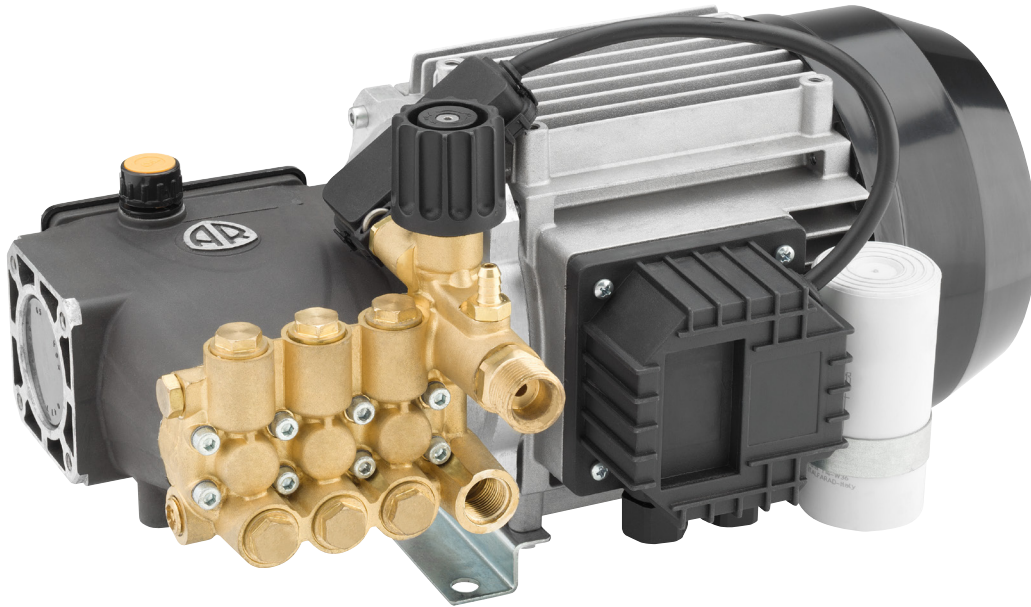

GR. 80 AR motor hollow shaft

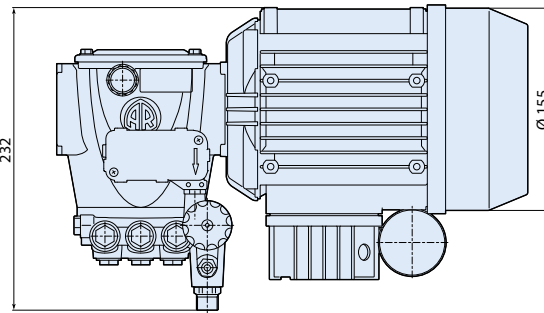
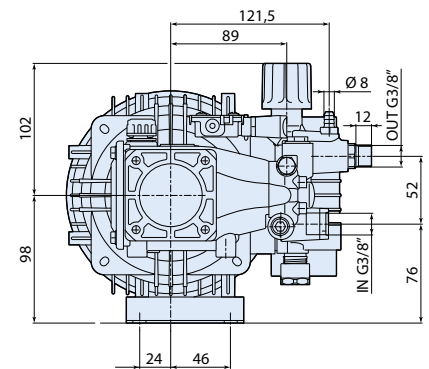
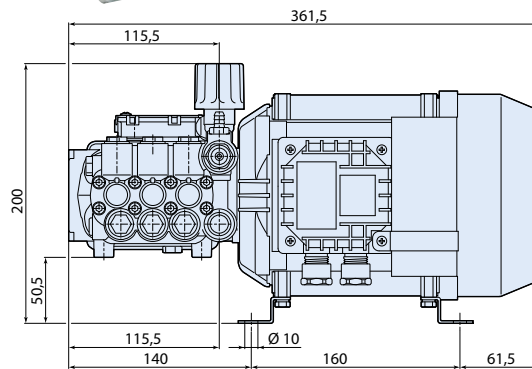

4148512

MOD	COD	MAX	MAX									
	1 ~	l/min	gpm	bar	psi	hp	kW	N° giri/1'	V 1-50Hz	Gr.	kg	
HJRS 2800 rpm												
HJRS 8.13 TSS EM	27162	8	2,11	130	1900	2,5	2	2800	230	80	19	
HJRS 8.15 TSS EM	27163	8	2,11	150	2200	3	2,2	2800	230	80	19	
HJRS 10.12 TSS EM	27164	10	2,69	120	1740	3	2,2	2800	230	80	19	

NEW



testa in
ottone
brass
head



bielle in
alluminio
connecting-rods
in aluminium



1-50Hz
frequenza
motore
motor
frequency



TSS
Total Stop
SYSTEM



Series 414

ELECTRIC MOTOR-PUMP UNITS



misting

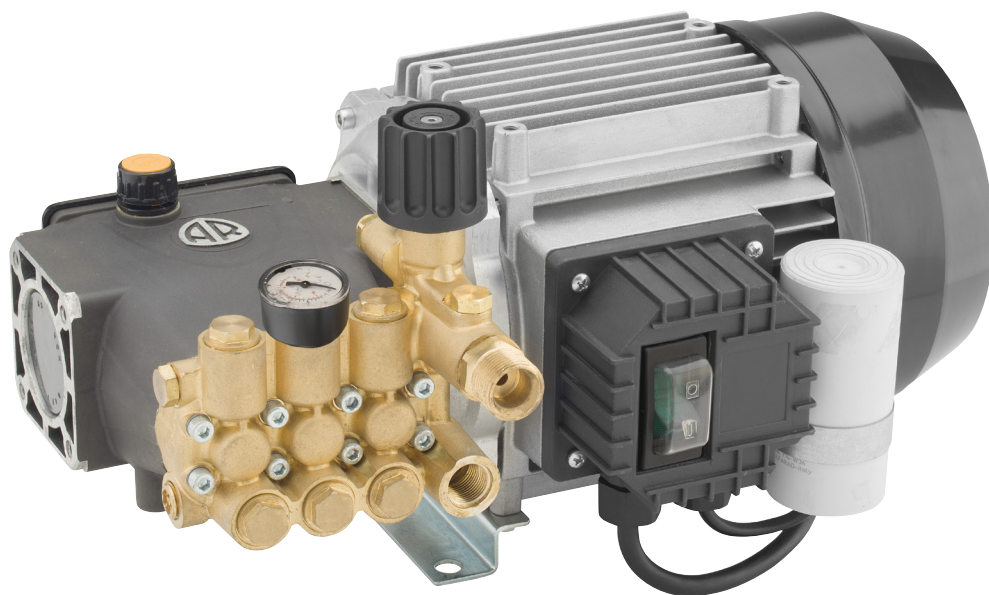

GR. 80 AR motor hollow shaft

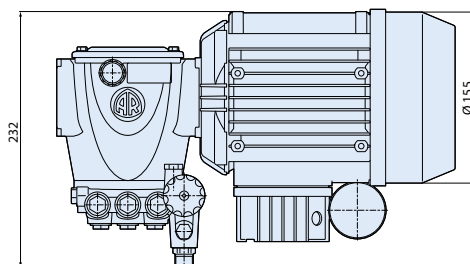
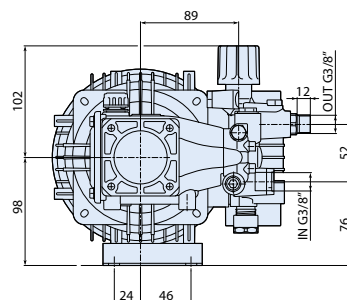
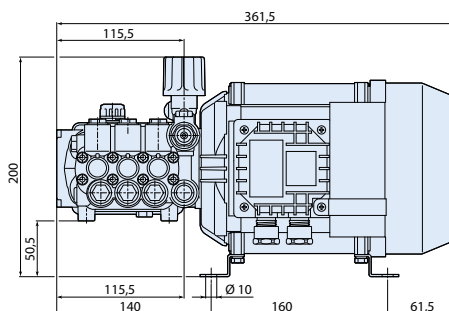

4148511

MOD	COD	MAX	MAX								
	1 ~	l/min	gpm	bar	psi	hp	kW	N° giri/1'	V 1-50Hz	Gr.	kg
HJR-M 1450rpm											
HJR-M 01.10 EM	27159	1	0,26	100	1450	0,5	0,35	1450	230	80	19
HJR-M 02.10 EM	27160	2	0,52	100	1450	0,5	0,35	1450	230	80	19
HJR-M 03.10 EM	27161	3	0,8	100	1450	0,8	0,6	1450	230	80	19

NEW



testa in ottone
brass head



bielle in alluminio
connecting-rods in aluminium



1~50Hz
frequenza motore
motor frequency



320 SERIES

RC
RCA
RCS
RCV
HRC

RC-M
RCA-M



Corpo e coperchi in alluminio pressofuso.

Coperchio laterale chiuso o con livello olio. Coperchio posteriore con scarico olio.

Bielle in lega zinco- alluminio pressofuso.

Testa in ottone stampato con possibilità di valvola di regolazione integrata.

Pistoni in ceramica.

Pump body and back cover in pressure die-cast aluminium alloy.

Side cover closed or incorporated with oil sight glass. Back cover incorporated with oil drain outlet.

Connecting rods in die-cast zinc-aluminium alloy.

Pump head in forged brass. Possibility to have integrated pressure regulating valve on pump head.

Ceramic pistons.



idropultrici
pressure
washers

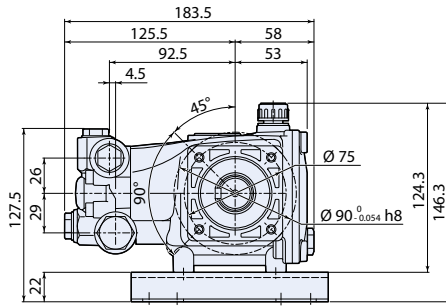

Piedi a richiesta.
Base on request.

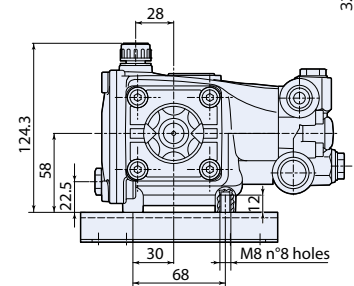
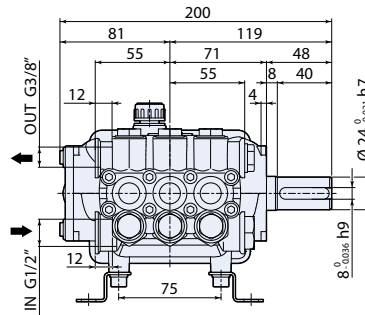

3208500

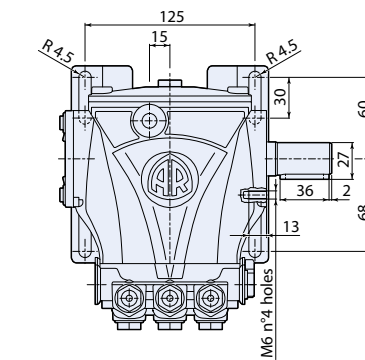

Flangiatura compatibile XT N.
XT N flange type.

N version

MOD	COD	MAX	MAX						
		l/min	gpm	bar	psi	hp	kw	N° giri/1'	kg

RC 1450rpm Nversion Ø24mm

RC 8.15 N	23260	8	2,11	150	2200	3	2,2	1450	5
RC 9.15 N	23263	9	2,37	150	2200	3,5	3	1450	5
RC 10.12 N	23384	10	2,64	120	1740	3	2,2	1450	5
RC 10.15 N	23436	10	2,64	150	2200	4	3	1450	5
RC 11.17 N	23261	11	2,90	170	2500	5	3,7	1450	5
RC 12.17 N	23262	12	3,20	170	2500	5,5	4	1450	5
RC 13.17 N	23081	13	3,43	170	2500	5,5	4	1450	5
RC 14.16 N	23301	14	3,70	160	2300	5,5	4	1450	5
RC 14.20 N	26920	14	3,70	200	2900	7,5	5,5	1450	5

RCA 1750rpm Nversion Ø24mm

RCA 2.5 G25 N	23437	9,5	2,5	170	2500	4,5	3,3	1750	5
RCA 3 G25 N	23438	11,4	3	170	2500	5	3,7	1750	5
RCA 3.5 G25 N	23264	13,2	3,5	170	2500	5,5	4	1750	5

RCS 2800rpm Nversion Ø24mm

RCS 8.17 N	23667	8	2,11	170	2500	3	2,2	2800	5
RCS 11.17 N	23670	11	2,90	170	2500	5	3,7	2800	5
RCS 13.17 N	23671	13	3,43	170	2500	5,5	4	2800	5
RCS 15.15 N	23672	15	3,96	150	2200	5,5	4	2800	5



testa in
ottone
brass
head



bielle in
alluminio
connecting-rods
in aluminium



320 series

POMPA ALBERO CAVO Hollow shaft pump



idropultrici
pressure
washers

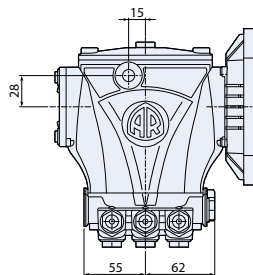
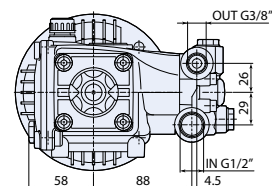
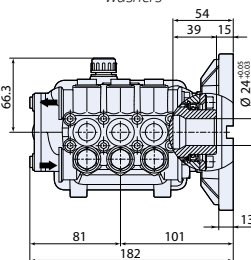
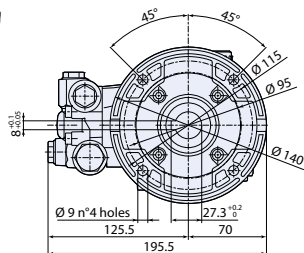

3208503

C version + F6

MOD	COD	MAX	MAX		KG NET				
		l/min	gpm	bar	psi	hp	kW	N° giri/1'	kg

RC 1450rpm Cversion + F6 Ø24mm

RC 8.15 C + F6	23493	8	2,11	150	2200	3	2,2	1450	5,5
RC 9.14 C + F6	23494	9	2,37	140	2000	3,3	2,4	1450	5,5
RC 11.11 C + F6	23495	11	2,90	110	1600	3	2,2	1450	5,5

Flangia F6, per motori elettrici B14 Gr.90 IEC34-7, 4 poli 50Hz. Flangia inclusa.
F6 flange for electric motor B14 90 IEC34-7, 4 poles 50Hz. Flange included.



testa in
ottone
brass
head



bielle in
alluminio
connecting-rods
in aluminium

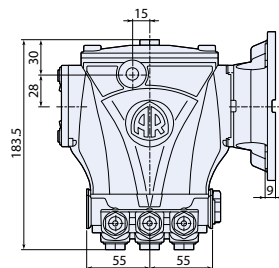
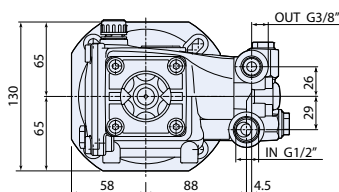
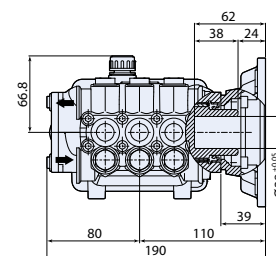
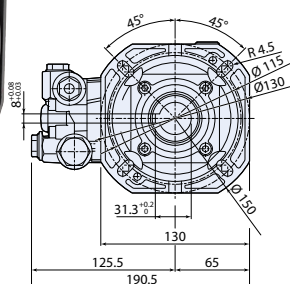

3208509



idropultrici
pressure
washers

POMPA ALBERO CAVO Hollow shaft pump

C version + F44

MOD	COD	MAX	MAX		KG NET				
		l/min	gpm	bar	psi	hp	kW	N° giri/1'	kg

RC 1450rpm Cversion + F44 Ø28mm

RC 12.10 C + F44	23902	12	3,20	100	1450	3	2,2	1450	5,5
RC 13.17 C + F44	23535	13	3,43	170	2500	5,5	4	1450	5,5
RC 14.16 C + F44	23536	14	3,70	160	2300	5,5	4	1450	5,5

Flangia F44 per motori elettrici B14 Gr.100 IEC34-7, 4 poli 50Hz. Flangia inclusa.
F44 flange for electric motor B14 100 IEC34-7, 4 poles 50Hz. Flange included.



testa in
ottone
brass
head



bielle in
alluminio
connecting-rods
in aluminium

320 Series

POMPA ALBERO CAVO Hollow shaft pump



idropultrici
pressure
washers

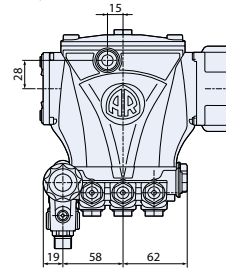
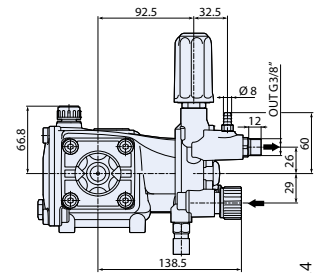
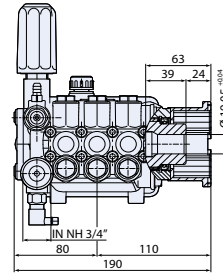
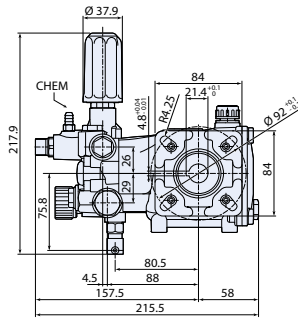

3208524

D version + F7

MOD	COD	MAX	MAX		NET				
		l/min	gpm	bar	psi	hp	kW	N° giri/1'	kg

RCV 3400rpm Dversion + F7 Ø 3/4"									
RCV 2.5 G25 D + F7	23970	9,5	2,5	170	2500	4,5	3,3	3400	5,5
RCV 3 G25 D + F7	23471	11,4	3	170	2500	5	3,7	3400	5,5
RCV 3.5 G25 D + F7	23971	13,2	3,5	170	2500	5,5	4	3400	5,5

Per motori scoppio flangia Ø 3/4" SAE J609a. Flangia inclusa.
For gasoline engine flange Ø 3/4" SAE J609a. Flange included.



testa in
ottone
brass
head



bielle in
alluminio
connecting-rods
in aluminium

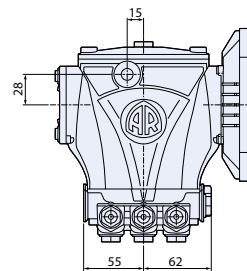
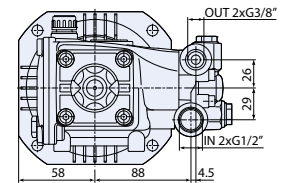
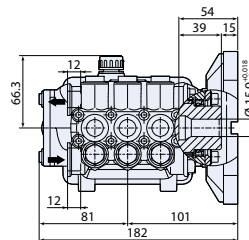
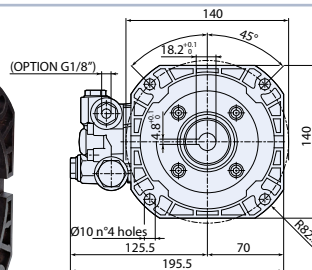

3208502



idropultrici
pressure
washers

E version + F8

MOD	COD	MAX	MAX		NET				
		l/min	gpm	bar	psi	hp	kW	N° giri/1'	kg

RCA 1750rpm Eversion + F8 Ø 5/8"									
RCA 2 G22 E + F8	23439	8	2,11	150	2200	3	2,2	1750	5,5
RCA 3 G18 E + F8	23440	11,4	3	120	1740	4	3	1750	5,5
RCA 3.5 G16 E + F8	23468	13,2	3,5	110	1600	4	3	1750	5,5

RCV 3400rpm Eversion + F8 Ø 5/8"									
RCV 2 G25 E + F8	23469	8	2,11	170	2500	5	3,7	3400	5,5
RCV 3 G25 E + F8	23107	11,4	3	170	2500	5	3,7	3400	5,5



testa in
ottone
brass
head



bielle in
alluminio
connecting-rods
in aluminium

Flangia F8 per motori elettrici NEMA 56-C, 60Hz. Flangia inclusa.
F8 flange for electric motor NEMA 56-C, 60Hz. Flange included.



320 series

POMPA ALBERO MASCHIO Solid shaft pump

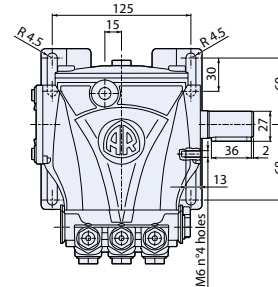
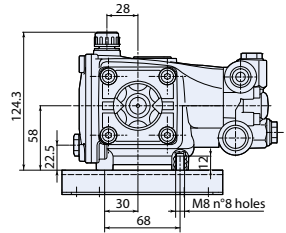
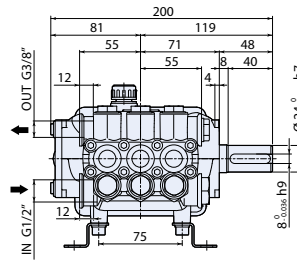
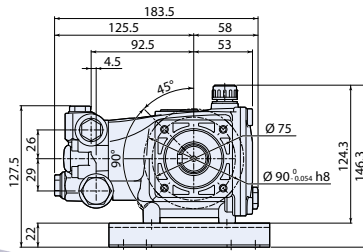

Piedi a richiesta.
Base on request.

3208500



misting

N version

Flangiatura compatibile XT N.
XT N flange type.

MOD	COD	MAX	MAX						
		l/min	gpm	bar	psi	hp	kW	N° giri/1'	kg
RC-M 1450rpm Nversion Ø24mm									
RC-M 01.10 N	23441	1	0,26	100	1450	0,26	0,2	1450	5
RC-M 02.10 N	23432	2	0,52	100	1450	0,52	0,4	1450	5
RC-M 03.10 N	23442	3	0,80	100	1450	0,78	0,58	1450	5
RC-M 04.10 N	23083	4	1,06	100	1450	1,05	0,77	1450	5
RC-M 05.10 N	23443	5	1,33	100	1450	1,31	0,98	1450	5
RC-M 06.10 N	23444	6	1,58	100	1450	1,57	1,17	1450	5



testa in ottone
brass head



bielle in alluminio
connecting-rods in aluminium

POMPA ALBERO CAVO Hollow shaft pump

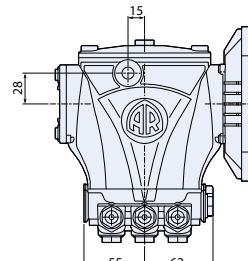
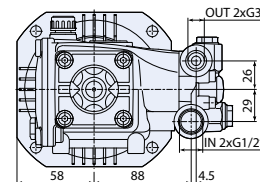
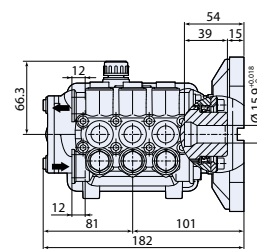
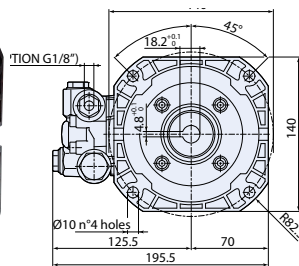
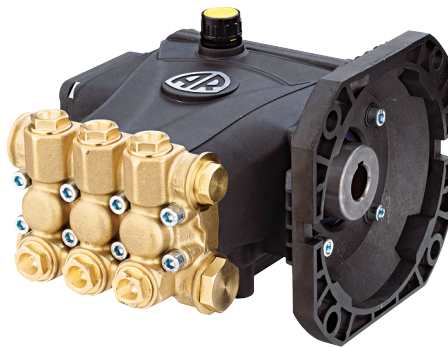

3208502



misting

E version + F8

MOD	COD	MAX	MAX						
		l/min	gpm	bar	psi	hp	kW	N° giri/1'	kg
RCA-M 1750rpm Eversion + F8 Ø 5/8"									
RCA-M 0.5G15 E + F8	23349	2	0,52	100	1450	0,52	0,4	1750	5,5
RCA-M 1G15 E + F8	23108	4	1,06	100	1450	1,26	0,93	1750	5,5
RCA-M 2G15 E + F8	23445	8	2,11	100	1450	2,10	1,55	1750	5,5



testa in ottone
brass head



bielle in alluminio
connecting-rods in aluminium

Flangia F8 per motori elettrici NEMA 56-C, 60Hz. Flangia inclusa.
F8 flange for electric motor NEMA 56-C, 60Hz. Flange included.



idropultrici
pressure
washers

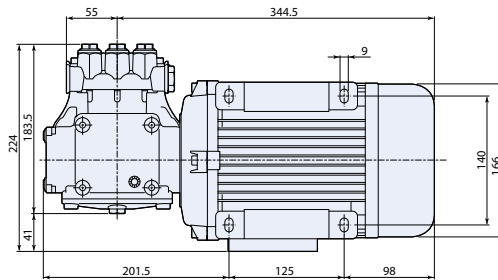
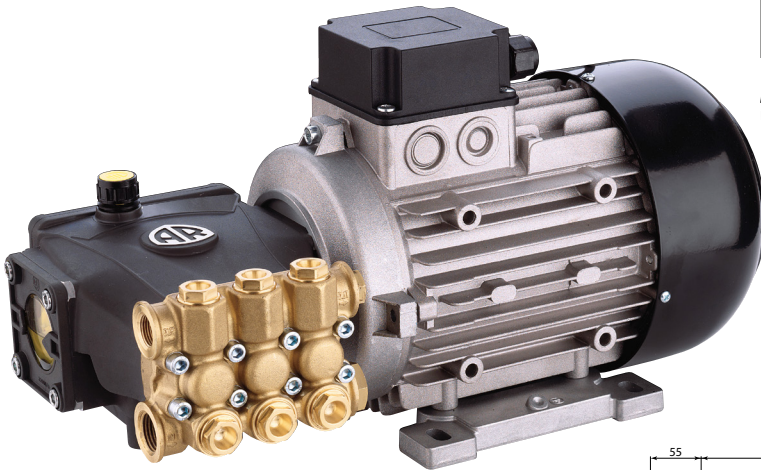

GR. 90L motor hollow shaft
1~

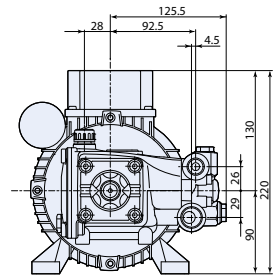
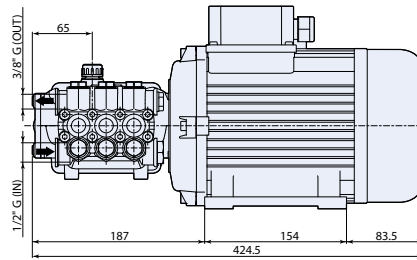

3208525

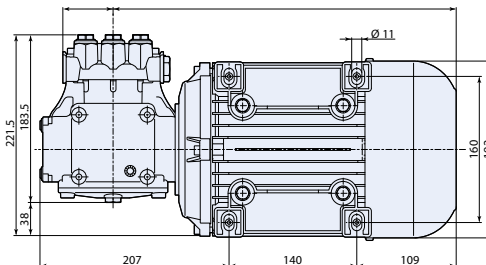

GR. 100 motor hollow shaft
3~

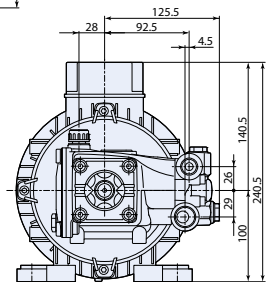
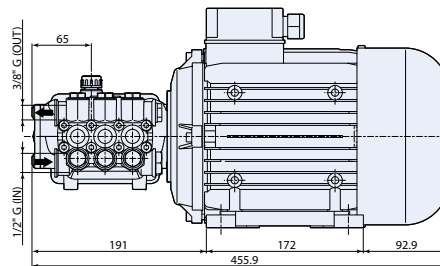

3208510

MOD	COD	MAX	MAX		KG NET								
	1~	3~	l/min	gpm	bar	psi	hp	kW	N° giri/1'	V 1-50Hz	V 3-50Hz	Gr.	kg
HRC 1450rpm													
HRC 10.13 EM	23485	-	10	2,64	130	1900	3	2,2	1450	230	-	90	22,3
HRC 12.11 EM	23486	-	12	3,20	110	1600	3	2,2	1450	230	-	90	22,3
HRC 11.15 ET	-	23453	11	2,90	150	2200	4	3	1450	-	230/400	100	28
HRC 13.17 ET	-	23454	13	3,43	170	2500	5,5	4	1450	-	230/400	100	30
HRC 14.16 ET	-	23455	14	3,70	160	2300	5,5	4	1450	-	230/400	100	30



testa in
ottone
brass
head



bielle in
alluminio
connecting-rods
in aluminium



1~50Hz
frequenza
motore
motor
frequency



3~50Hz
frequenza
motore
motor
frequency

132 SERIES

XT
XTS
XTA
XTV
HXT



Corpo e coperchi in alluminio pressofuso.

Coperchio posteriore con livello olio.

Bielle in lega zinco- alluminio pressofuso oppure in bronzo.

Testa in ottone stampato o in lega d'alluminio pressofuso.

Pistoni in ceramica.

Pump body and back cover in pressure die-cast aluminium alloy.

Back cover incorporated with oil sight glass.

Connecting rods in die-cast zinc-aluminium alloy. Bronze connecting rods available.

Pump head in forged brass or die-cast aluminium alloy.

Ceramic pistons.

132 Series

POMPA ALBERO MASCHIO Solid shaft pump



idropultrici
pressure
washers





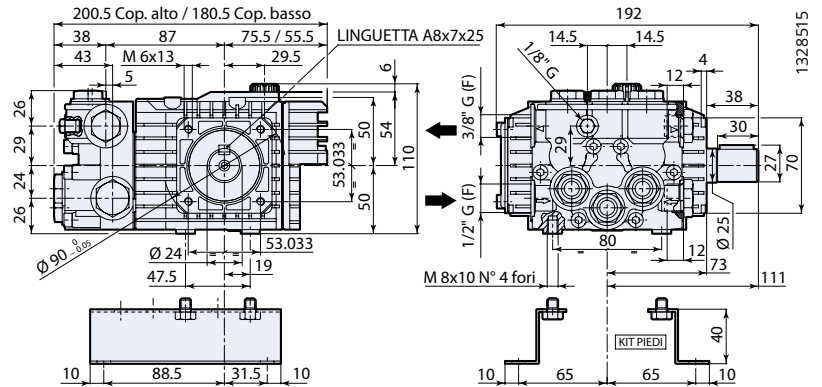

● Model brass head



Piedi a richiesta.
Base on request.

N version

MOD	COD	 MAX	 MAX							
		l/min	gpm	bar	psi	hp	kW	N° giri/1'	kg	
XT 1450rpm Nversion Ø24mm										
XT 8.10 N	7002	8	2,11	100	1450	2	1,5	1450	3,8	
● XT 8.15 N	● 6979	8	2,11	150	2200	3	2,2	1450	5	
XT 9.11 N	● 7006	9	2,37	110	1600	2,5	1,8	1450	4	
● XT 9.15 N	● 6980	9	2,37	150	2200	3,5	3,2	1450	5	
XT 10.10 N	● 7334	10	2,64	100	1450	2,5	1,8	1450	4	
● XT 10.15 N	● 6978	10	2,64	150	2200	4	3	1450	5	
XT 11.07 N	7003	11	2,90	70	1000	2	1,5	1450	3,8	
● XT 11.15 N	● 6981	11	2,90	150	2200	4,3	3,2	1450	5	
XT 13.09 N	● 7009	13	3,43	90	1300	3	2,2	1450	4	
● XT 13.15 N	● 6982	13	3,43	150	2200	5	3,6	1450	5	
XTS 2800rpm Nversion Ø24mm										
XTS 8.10 N	7032	8	2,11	100	1450	2	1,5	2800	3,8	
● XTS 8.15 N	● 7412	8	2,11	150	2200	3	2,2	2800	5	
XTS 10.10 N	7332	10	2,64	100	1450	2,5	1,8	2800	3,8	
● XTS 10.15 N	● 7413	10	2,64	150	2200	4	3	2800	5	
XTS 11.11 N	7035	11	2,90	110	1600	3	2,2	2800	3,8	
● XTS 11.15 N	● 7414	11	2,90	150	2200	4,3	3,2	2800	5	
XTS 13.09 N	7037	13	3,43	90	1300	3	2,2	2800	3,8	
● XTS 13.15 N	● 7415	13	3,43	150	2200	5	3,6	2800	5	
XTA 1750rpm Nversion Ø24mm										
XTA 2 G15 N	7072	8	2,11	100	1450	2	1,5	1750	3,8	
● XTA 2 G22 N	● 7416	8	2,11	150	2200	3	2,2	1750	5	
XTA 3 G16 N	● 7437	11,4	3	110	1600	3	2,2	1750	4	
● XTA 3 G22 N	● 7417	11,4	3	150	2200	4,5	3,4	1750	5	
XTA 3.5 G13 N	● 7438	13,2	3,5	90	1300	3	2,2	1750	4	
● XTA 3.5 G20 N	● 7418	13,2	3,5	140	2000	5	3,6	1750	5	
XTA 4 G10 N	7079	15,1	4	70	1000	3	2,2	1750	3,8	
XTA 4 G15 N	● 7083	15,1	4	100	1450	4	3	1750	4	



● testa in
ottone
brass
head



● bielle in
bronzo
connecting-rods
in bronze



● testa in
alluminio
aluminium
head



● bielle in
alluminio
connecting-rods
in aluminium



132 Series

POMPA ALBERO CAVO Hollow shaft pump



idropultrici
pressure
washers



● Model brass head

1328507

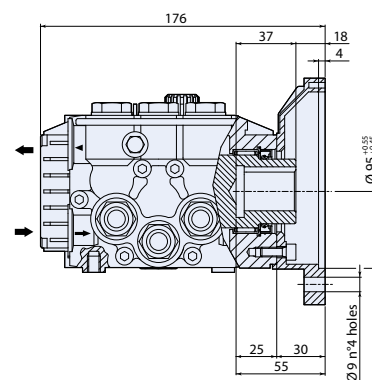
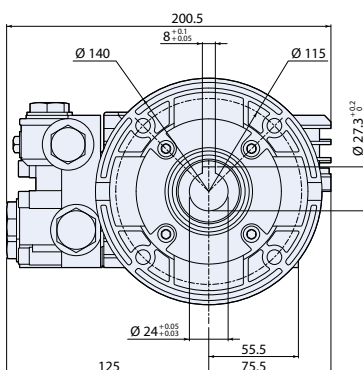

Flangia F6 fornita a richiesta.
F6 flange on request.

C version

MOD	COD	MAX		MAX		MAX			KG NET
		l/min	gpm	bar	psi	hp	kW	N° giri/1'	
XT 1450rpm Cversion Ø24mm									
XT 8.10 C	7018	8	2,11	100	1450	2	1,5	1450	3,8
● XT 8.14 C	● 7025	8	2,11	140	2000	3	2,2	1450	5
XT 9.11 C	● 7022	9	2,37	110	1600	2,5	1,8	1450	4
● XT 9.14 C	● 6991	9	2,37	140	2000	3,3	2,4	1450	5
XT 11.11 C	● 7103	11	2,90	110	1600	3	2,2	1450	4
● XT 11.14 C	● 7104	11	2,90	140	2000	4	3	1450	4
XT 13.09 C	● 7119	13	3,43	90	1300	3	2,2	1450	4
XTS 2800rpm Cversion Ø24mm									
XTS 8.10 C	7061	8	2,11	100	1450	2	1,5	2800	3,8
● XTS 8.14 C	● 7068	8	2,11	140	2000	3	2,2	2800	5
XTS 11.11 C	● 7064	11	2,90	110	1600	3	2,2	2800	4
● XTS 11.14 C	● 7069	11	2,90	140	2000	4	3	2800	5
XTS 13.09 C	● 7066	13	3,43	90	1300	3	2,2	2800	4
● XTS 13.12 C	● 7287	13	3,43	120	1740	4	3	2800	5



● testa in
ottone
brass
head



○ bielle in
bronzo
connecting-rods
in bronze



testa in
alluminio
aluminium
head



bielle in
alluminio
connecting-rods
in aluminium

Flangia F6, per motori elettrici B14 Gr.90 IEC34-7. Flangia non inclusa.
F6 flange for electric motor B14 90 IEC34-7. Flange not included.



idropultrici
pressure
washers

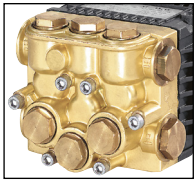

● Model brass head

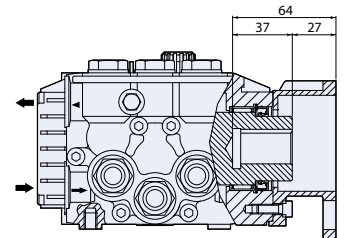
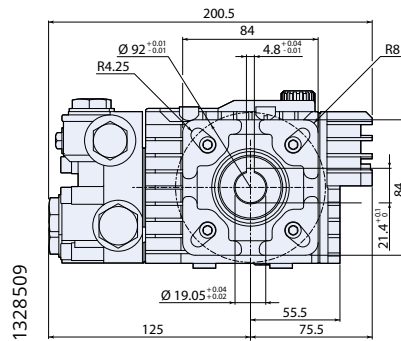

Flangia F7 fornita a richiesta.
F7 flange on request.

D version

MOD	COD	MAX		MAX		MAX		N° giri/1'	KG NET
		l/min	gpm	bar	psi	hp	kW		
XTV 3400rpm Dversion Ø3/4"									
XTV 2 G15 D	7294	8	2,11	100	1450	2	1,5	3400	3,8
● XTV 2 G22 D ●	7419	8	2,11	150	2200	3	2,2	3400	5
XTV 3 G10 D	7296	11,4	3	70	1000	2	1,5	3400	3,8
● XTV 3 G22 D ●	7420	11,4	3	150	2200	4,5	3,4	3400	5

Per motori scoppio flangia F7 Ø 3/4" SAE J609a. Flangia non inclusa.
For gasoline engine flange F7 Ø 3/4" SAE J609a. Flange not included.



● testa in
ottone
brass
head



○ bielle in
bronzo
connecting-rods
in bronze



● testa in
alluminio
aluminium
head



○ bielle in
alluminio
connecting-rods
in aluminium



132 Series

ELECTRIC MOTOR-PUMP UNITS



idropultrici
pressure
washers

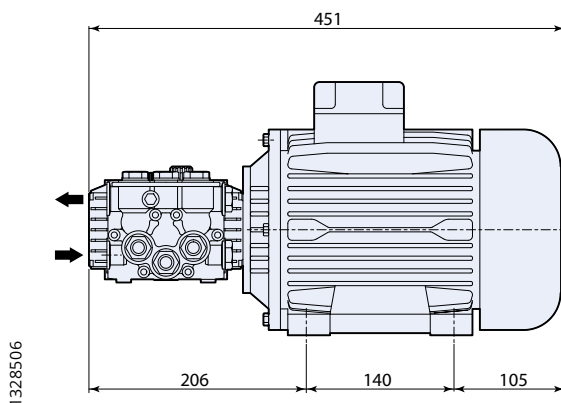

GR. 100 motor hollow shaft

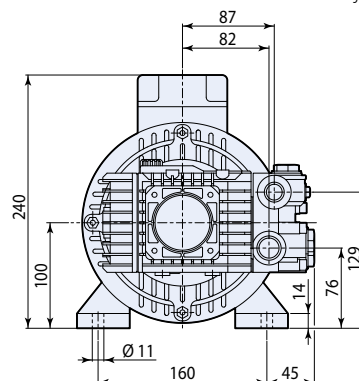

MOD	COD	MAX		MAX		hp	kW	N° giri/1'	V		Gr.	kg	
		l/min	gpm	bar	psi				1-50Hz	3-50Hz			
HXT 1450 rpm													
● HXT 8.14 EM	7146	-	8	2,11	140	2000	3	2,2	1450	230	-	100	28
● HXT 11.11 EM	7148	-	11	2,90	110	1600	3	2,2	1450	230	-	100	28
● HXT 11.14 ET	-	7154	11	2,90	140	2000	4	3	1450	-	230/400	100	30
● HXT 13.12 ET	-	7155	13	3,43	120	1740	4	3	1450	-	230/400	100	30



● testa in
ottone
brass
head



● testa in
alluminio
aluminium
head



● bielle in
bronzo
connecting-rods
in bronze



1~50Hz
frequenza
motore
motor
frequency



3~50Hz
frequenza
motore
motor
frequency



idropulitrici
pressure
washers

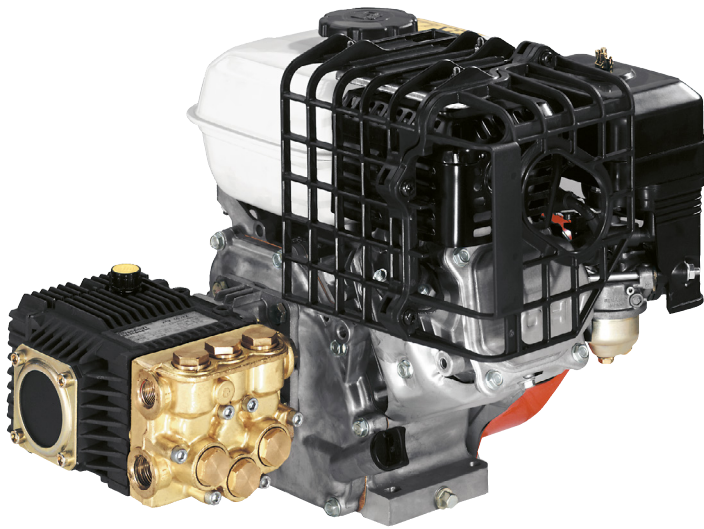

XTV 3400 rpm Direct Drive
from Honda engine

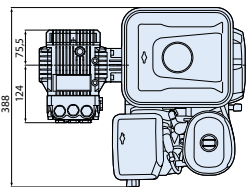
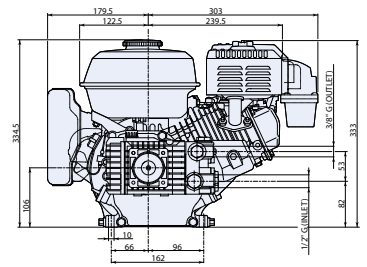
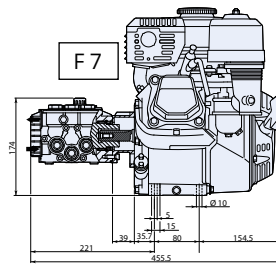
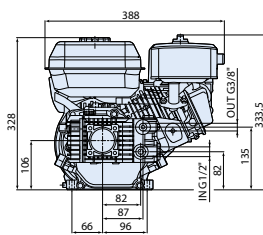
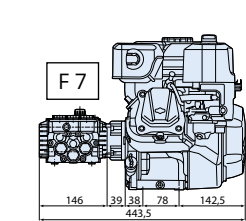

XTV 2 G15 B&S 550

1328519

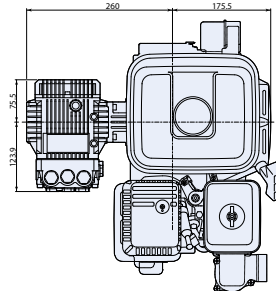

XTV 3 G16 Honda GX160

1328517

MOD	COD	Engine HP	l/min	gpm	bar	psi	N° giri/1'	kg
XTV Direct Drive								
XTV 2 G15 B&S 550	7466	3,5	8	2,11	100	1450	3400	18,5
● XTV 3 G16 HONDA GX 160K1-QX Type	7469	4,8	11,4	3	110	1600	3400	20



● **testa in ottone**
brass head



testa in alluminio
aluminium head



bielle in alluminio
connecting-rods in aluminium



motore a scoppio
gasoline engine

178 SERIES

XM · SXM
XMA · SXMA
XMS · SXMS
XMV · SXMV
XM-M
XHW

HXM · HSXM
XM+F38
HYD-XM



Corpo e coperchi in alluminio pressofuso.

Coperchio posteriore con livello olio e scarico olio.

Bielle in lega zinco-alluminio pressofuso oppure in bronzo.

Testa in ottone stampato.

Pistoni in ceramica.

Possibilità di avere il corpo con trattamento di cataforesi (versione hot water).

Pump body and back cover in pressure die-cast aluminium alloy.

Back cover incorporated with oil sight glass and oil drain outlet.

*Connecting rods in die-cast zinc-aluminium alloy.
Bronze connecting rods available.*

Pump head in forged brass.

Ceramic pistons.

Pump body with cathaphoresis treatment (hot water version).

178 Series

POMPA ALBERO MASCHIO Solid shaft pump





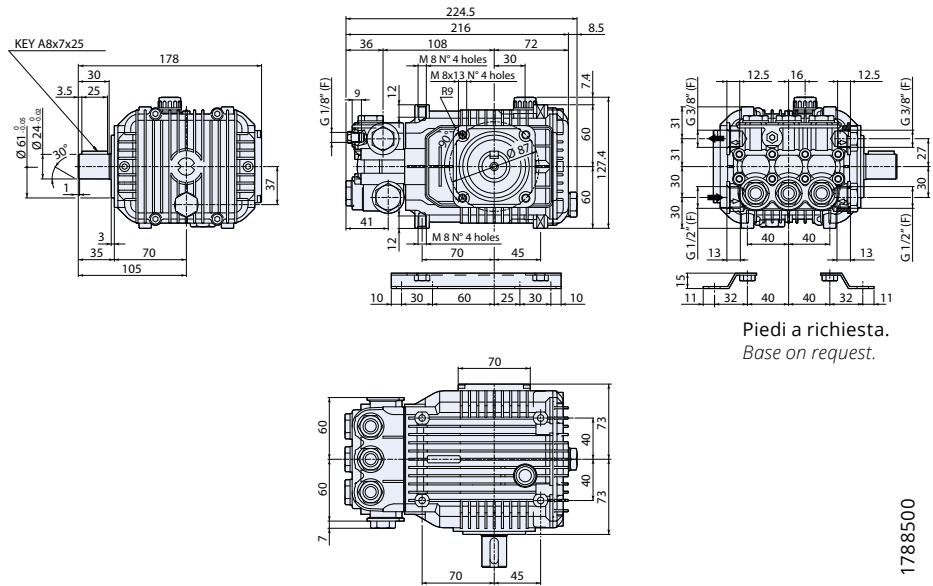







idropulitrici
pressure
washers



Piedi a richiesta.
Base on request.

1788500

N version

MOD	COD	 MAX	 MAX						
		l/min	gpm	bar	psi	hp	kW	N° giri/1'	kg
XM 1450rpm Nversion Ø24mm									
XM 11.17 N	7900	11	2,90	170	2500	5	3,7	1450	6,5
XM 13.17 N	7902	13	3,43	170	2500	5,5	4	1450	6,5
XM 15.15 N	7906	15	3,96	150	2200	5,5	4	1450	6,5
SXM 1450rpm Nversion Ø24mm									
SXM 11.20 N	 21374	11	2,90	200	2900	5,5	4	1450	6,5
SXM 13.20 N	 21267	13	3,43	200	2900	7,5	5,5	1450	6,5
SXM 15.20 N	 21265	15	3,96	200	2900	7,5	5,5	1450	6,5
XMS 2800rpm Nversion Ø24mm									
XMS 11.17 N	7908	11	2,90	170	2500	5	3,7	2800	6,5
XMS 13.17 N	7910	13	3,43	170	2500	5,5	4	2800	6,5
XMS 15.15 N	7912	15	3,96	150	2200	5,5	4	2800	6,5
XMS 15.20 N	20511	15	3,96	200	2900	7,5	5,5	2800	6,5
SXMS 2800rpm Nversion Ø24mm									
SXMS 11.20 N	 21376	11	2,90	200	2900	5,5	4,1	2800	6,5
SXMS 13.20 N	 21257	13	3,43	200	2900	7,5	5,5	2800	6,5
SXMS 15.20 N	 21258	15	3,96	200	2900	7,5	5,5	2800	6,5



testa in
ottone
brass
head



bielle in
bronzo
connecting-rods
in bronze



bielle in
alluminio
connecting-rods
in aluminium



178 Series

POMPA ALBERO MASCHIO Solid shaft pump



idropulitrici
pressure
washers

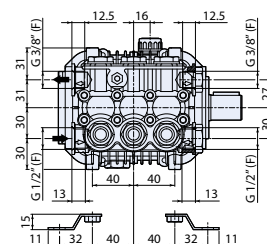
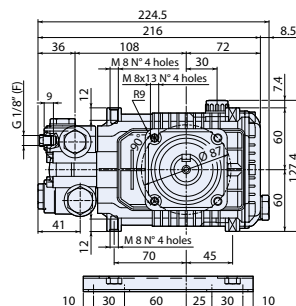
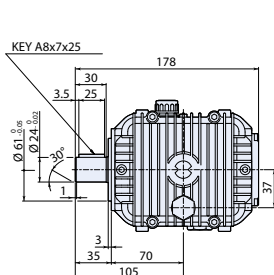

Piedi a richiesta.
Base on request.

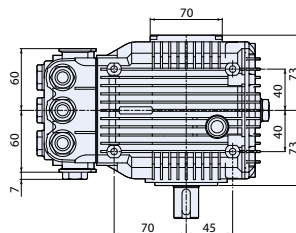

1788500

N version

MOD	COD	MAX	MAX	MAX	MAX	MAX	MAX	MAX	NET
		l/min	gpm	bar	psi	hp	kW	N° giri/1'	kg
XMA 1750rpm Nversion Ø24mm									
XMA 3 G25 N	7916	11,4	3	170	2500	5	3,7	1750	6,5
XMA 3.5 G22 N	7918	13,2	3,5	150	2200	5	3,7	1750	6,5
XMA 3.5 G25 N	7920	13,2	3,5	170	2500	5,5	4	1750	6,5
XMA 4 G20 N	7922	15,1	4	140	2000	5,5	4	1750	6,5
SXMA 1750rpm Nversion Ø24mm									
SXMA 3 G30 N	21401	11,4	3	205	3000	5,5	4	1750	6,5
SXMA 3.5 G30 N	21406	13,2	3,5	205	3000	7	5,2	1750	6,5
SXMA 4 G30 N	21261	15,1	4	205	3000	7,5	5,5	1750	6,5
XMV 3400rpm Nversion Ø24mm									
XMV 3 G30 N	20529	11,4	3	205	3000	5,5	4	3400	6,5
XMV 3.5 G25 N	7928	13,2	3,5	170	2500	5,5	4	3400	6,5
XMV 4 G22 N	7932	15,1	4	150	2200	5,5	4	3400	6,5
XMV 4 G30 N	20849	15,1	4	205	3000	7,5	5,5	3400	6,5
SXMV 3400rpm Nversion Ø24mm									
SXMV 3 G35 N	21379	11,4	3	240	3500	7,5	5,5	3400	6,5
SXMV 3.5 G35 N	21380	13,2	3,5	240	3500	10	7,5	3400	6,5
SXMV 4 G35 N	21263	15,1	4	240	3500	10	7,5	3400	6,5



testa in
ottone
brass
head



bielle in
bronzo
connecting-rods
in bronze



bielle in
alluminio
connecting-rods
in aluminium

178 Series

POMPA ALBERO CAVO Hollow shaft pump



idropulitrici
pressure
washers

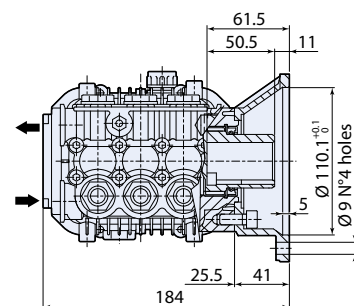
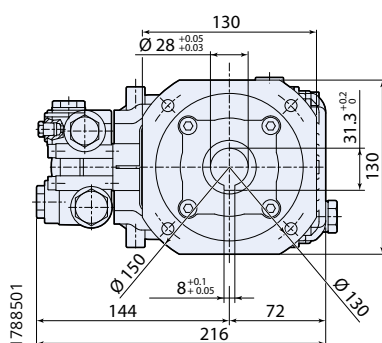

Flangia F16 fornita a richiesta.
F16 flange on request.

C version

MOD	COD	MAX		MAX		MAX		N° giri/1'	kg NET
		l/min	gpm	bar	psi	hp	kW		
XM 1450rpm Cversion Ø28mm									
XM 11.17 C	7936	11	2,90	170	2500	5	3,7	1450	6,5
XM 13.17 C	7938	13	3,43	170	2500	5,5	4	1450	6,5
XM 15.15 C	7942	15	3,96	150	2200	5,5	4	1450	6,5
SXM 1450rpm Cversion Ø28mm									
SXM 11.20 C	21375	11	2,90	200	2900	5,5	4	1450	6,5
SXM 13.20 C	21255	13	3,43	200	2900	7,5	5,5	1450	6,5
SXM 15.20 C	21256	15	3,96	200	2900	7,5	5,5	1450	6,5
XMS 2800rpm Cversion Ø28mm									
XMS 11.17 C	7944	11	2,90	170	2500	5	3,7	2800	6,5
XMS 13.17 C	7946	13	3,43	170	2500	5,5	4	2800	6,5
XMS 15.15 C	7948	15	3,96	150	2200	5,5	4	2800	6,5
SXMS 2800rpm Cversion Ø28mm									
SXMS 11.20 C	21377	11	2,90	200	2900	5,5	4	2800	6,5
SXMS 13.20 C	21259	13	3,43	200	2900	7,5	5,5	2800	6,5
SXMS 15.20 C	21260	15	3,96	200	2900	7,5	5,5	2800	6,5



Flangia F16 per motori elettrici B14 Gr.100÷112 IEC34-7, 50Hz. Flangia non inclusa.
F16 flange for electric motor B14 100÷112 IEC34-7, 50Hz. Flange not included.



178 Series

POMPA ALBERO CAVO Hollow shaft pump



idropultrici
pressure
washers

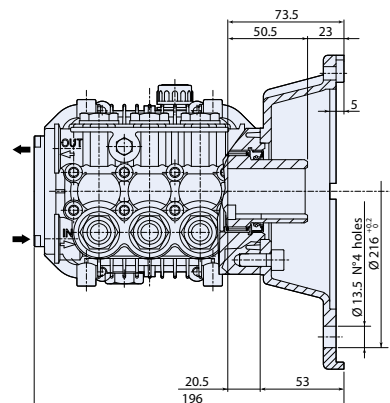
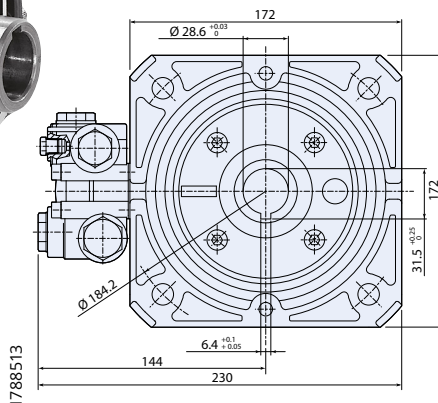

Flangia F17 fornita a richiesta.
F17 flange on request.

E version

MOD	COD	MAX	MAX	MAX	MAX	MAX	MAX	MAX	NET
		l/min	gpm	bar	psi	hp	kW	N° giri/1'	kg
XMA 1750rpm Eversion Ø 1" 1/8									
XMA 3 G25 E	7952	11,4	3	170	2500	5	3,7	1750	6,5
XMA 3.5 G25 E	7956	13,2	3,5	170	2500	5,5	4	1750	6,5
XMA 4 G20 E	7958	15,1	4	140	2000	5,5	4	1750	6,5



testa in
ottone
brass
head



bielle in
alluminio
connecting-rods
in aluminium

Flangia F17 per motori elettrici NEMA 182-184, 4 poli 60Hz. Flangia non inclusa.
F17 flange for electric motor NEMA 182-184, 4 poles 60Hz. Flange not included.

POMPA ALBERO CAVO Hollow shaft pump



idropultrici
pressure
washers

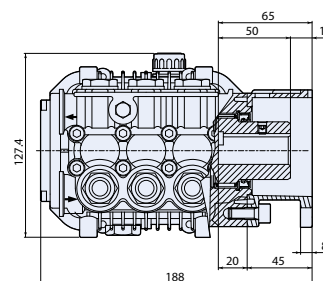
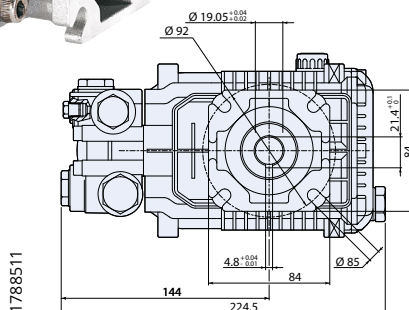

Flangia F25 fornita a richiesta.
F25 flange on request.

E version + F25

MOD	COD	MAX	MAX	MAX	MAX	MAX	MAX	MAX	NET
		l/min	gpm	bar	psi	hp	kW	N° giri/1'	kg
XMV 3400rpm Eversion + F25 Ø 3/4"									
XMV 3 G30 D + F25	20095	11,4	3	205	3000	5,5	4	3400	7
XMV 3.5 G25 D + F25	7996	13,2	3,5	170	2500	5,5	4	3400	7



testa in
ottone
brass
head



bielle in
alluminio
connecting-rods
in aluminium

Flangia F25 per motori scoppio Ø 3/4" SAE J609a. Flangia inclusa.
F25 flange for gasoline engine Ø 3/4" SAE J609a. Flange included.

178 Series

POMPA ALBERO CAVO Hollow shaft pump

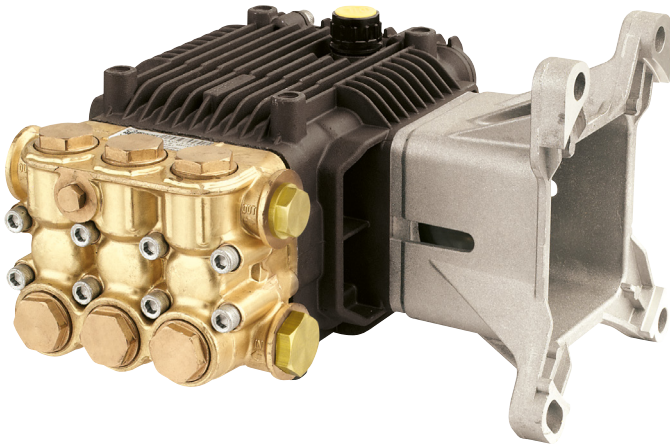

idropulitrici
pressure
washers

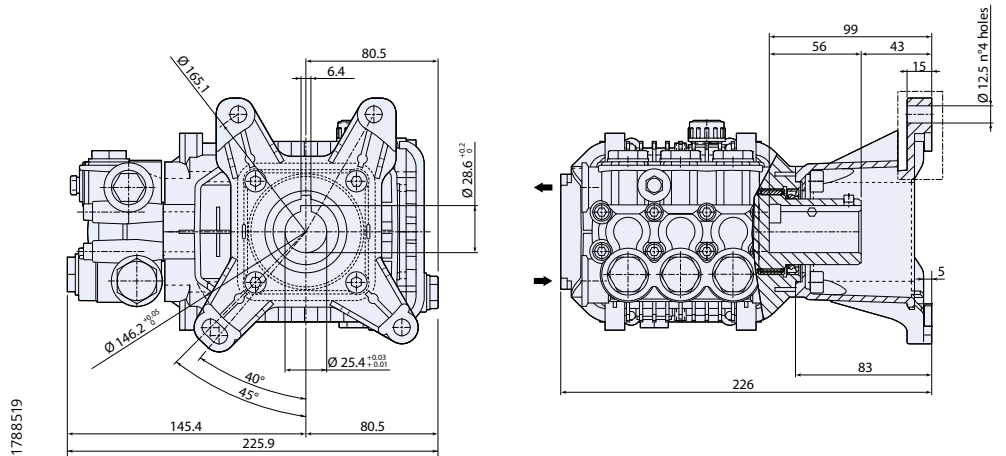

D version + F40

MOD	COD	MAX		MAX				KG NET	
		l/min	gpm	bar	psi	hp	kW	N° giri/1'	kg
XMV 3400rpm Dversion + F40 Ø1"									
XMV 3 G30 D + F40	20111	11,4	3	205	3000	5,5	4	3400	7
XMV 3.5 G30 D + F40	21128	13,2	3,5	205	3000	7	5,2	3400	7
XMV 4 G25 D + F40	7990	15,1	4	170	2500	7	5,2	3400	7
XMV 4 G30 D + F40	20820	15,1	4	205	3000	7,5	5,5	3400	7
SXMV 3400rpm Dversion + F40 Ø1"									
SXMV 3 G35 D + F40	21381	11,4	3	240	3500	7,5	5,5	3400	7
SXMV 3.5 G35 D + F40	21382	13,2	3,5	240	3500	8,5	6,2	3400	7
SXMV 4 G35 D + F40	21264	15,1	4	240	3500	10	7,5	3400	7

Flangia F40 per motori scoppio Ø 1" SAE J609a. Flangia inclusa.
F40 flange for gasoline engine Ø 1" SAE J609a. Flange included.



testa in
ottone
brass
head



bielle in
bronzo
connecting-rods
in bronze



bielle in
alluminio
connecting-rods
in aluminium



178 Series

POMPA ALBERO MASCHIO Solid shaft pump



misting

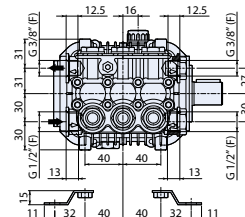
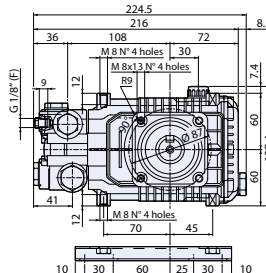
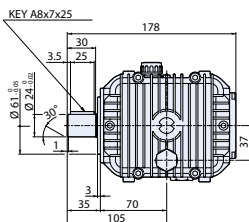

Piedi a richiesta.
Base on request.

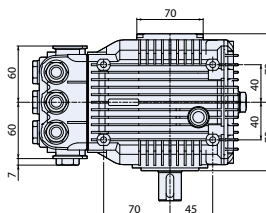

1788500

N version

MOD	COD	MAX	MAX						
		l/min	gpm	bar	psi	hp	kW	N° giri/1'	kg
XM-M 1450rpm Nversion Ø24mm									
XM-M 01.10 N	22092	1	0,26	100	1450	0,3	0,2	1450	6,5
XM-M 02.10 N	22093	2	0,52	100	1450	0,5	0,4	1450	6,5
XM-M 04.10 N	22094	4	1,06	100	1450	1	0,8	1450	6,5
XM-M 08.10 N	22095	8	2,11	100	1450	2	1,5	1450	6,5



testa in ottone
brass head



bielle in alluminio
connecting-rods in aluminium

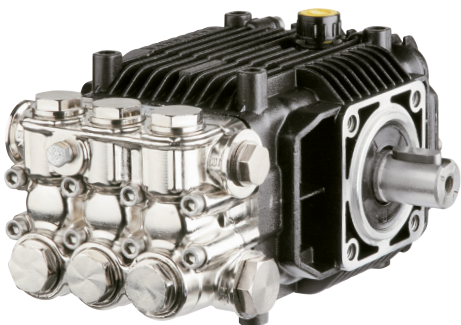

POMPA ALBERO MASCHIO Solid shaft pump

HOT WATER 85°C

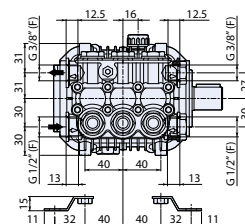
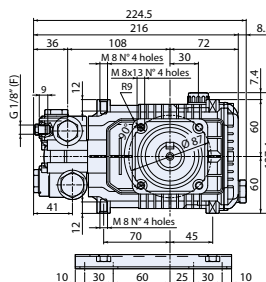
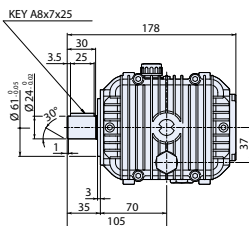

Piedi a richiesta.
Base on request.

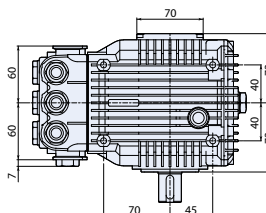

1788500



autolavaggio municipality
car wash

N version

MOD	COD	MAX	MAX						
		l/min	gpm	bar	psi	hp	kW	N° giri/1'	kg
XHW 1450rpm Nversion Ø24mm									
XHW 08.15 N	23972	8	2,11	150	2200	3	2,2	1450	6,5
XHW 11.17 N	22543	11	2,90	170	2500	5	3,7	1450	6,5



testa nichelata
nickel plated brass head



guarnizioni in PTFE
PTFE gasket sealing



bielle in bronzo
connecting-rods in bronze



idropultrici
pressure
washers

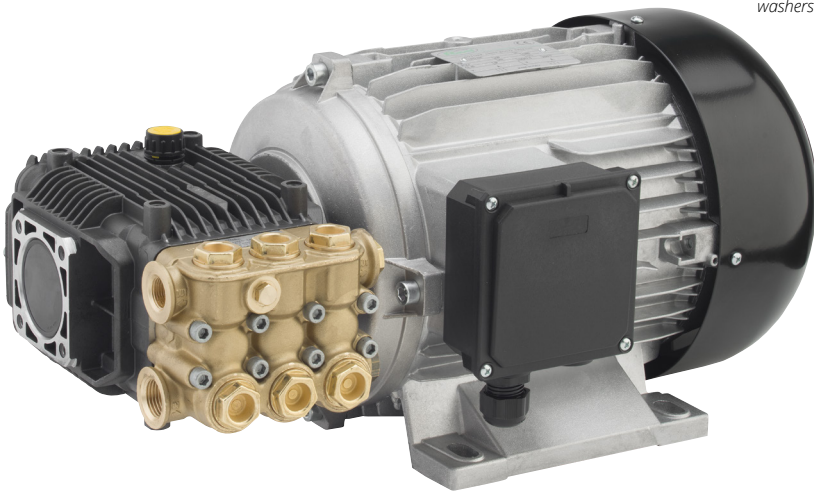

GR. 112 motor hollow shaft

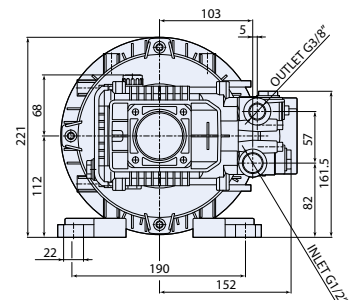
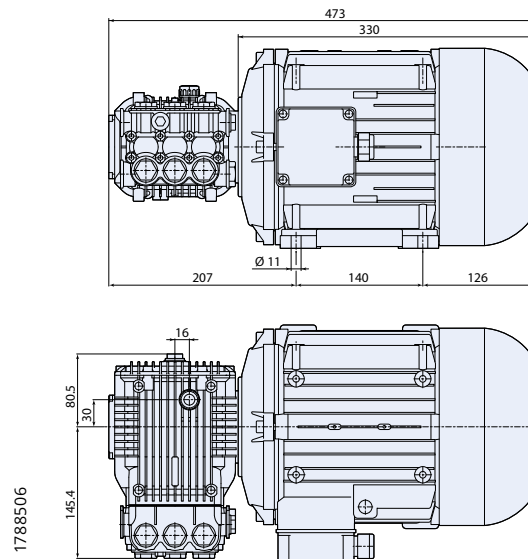

MOD	COD	MAX		MAX						KG	
	3 ~	l/min	gpm	bar	psi	hp	kW	N° giri/1'	V 3-50Hz	Gr.	kg
HXM - HSXM 1450rpm											
HXM 13.17 ET	20196	13	3,43	170	2500	5,5	4	1450	230/400	112	30
HSXM 13.20 ET	21370	13	3,43	200	2900	7,5	5,5	1450	230/400	112	38
HXM 15.15 ET	20197	15	3,96	150	2200	5,5	4	1450	230/400	112	30
HSXM 15.20 ET	21371	15	3,96	200	2900	7,5	5,5	1450	230/400	112	38



testa in
ottone
brass
head



bielle in
bronzo
connecting-rods
in bronze



bielle in
alluminio
connecting-rods
in aluminium



frequenza
motore
motor
frequency



178 Series

GASOLINE MOTOR-PUMP UNITS



idropultrici
pressure
washers

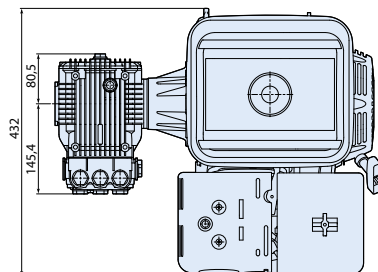
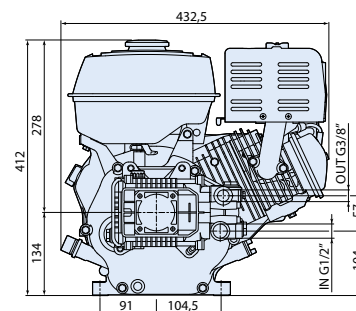
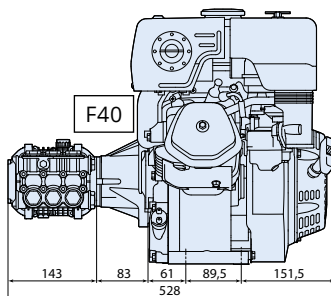
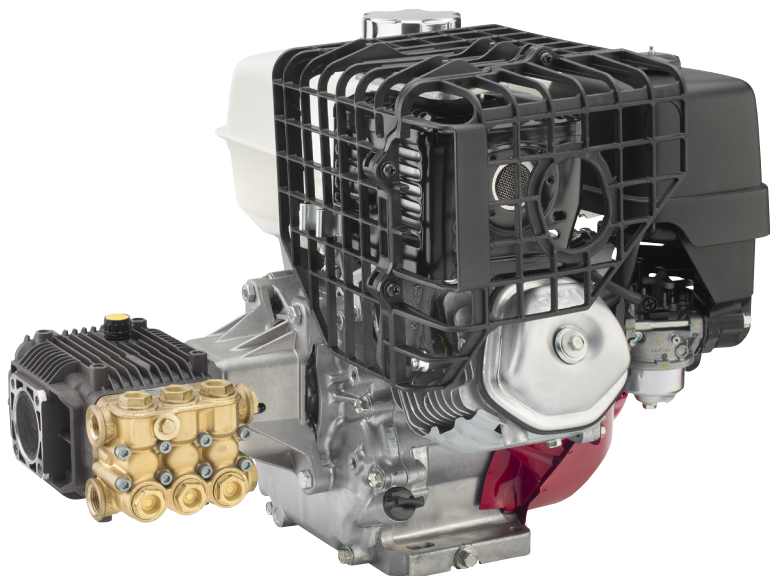

1788538

MOD	COD	MAX	MAX	RPM	NET		
		l/min	gpm	bar	psi	N° giri/1'	kg
XMV Direct Drive							
XMV 4 G20 HONDA GX 270-QX Type	8,4 20237	15,1	4	140	2000	3400	32



testa in
ottone
brass
head



bielle in
alluminio
connecting-rods
in aluminium



motore a
scoppio
gasoline
engine

178 Series

HYDRAULIC DRIVE

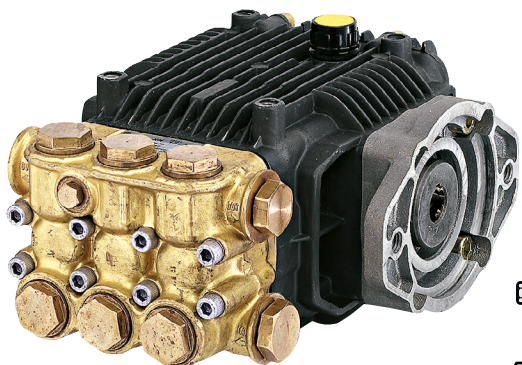

municipality

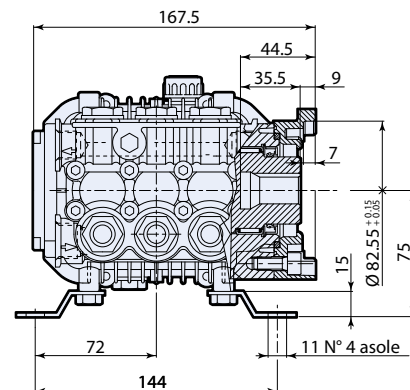
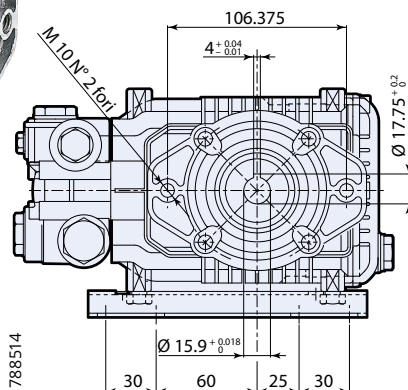

Piedi a richiesta.
Base on request.

XM + F38

MOD	COD	MAX	gpm	MAX	psi	hp	kW	N° giri/1'	NET	kg
l/min										
XM 1450rpm + F38										
XM 15.15 + F38	21598	15	3,96	150	2200	5,5	4	1450	3,2	



testa in ottone
brass head



bielle in alluminio
connecting-rods in aluminium

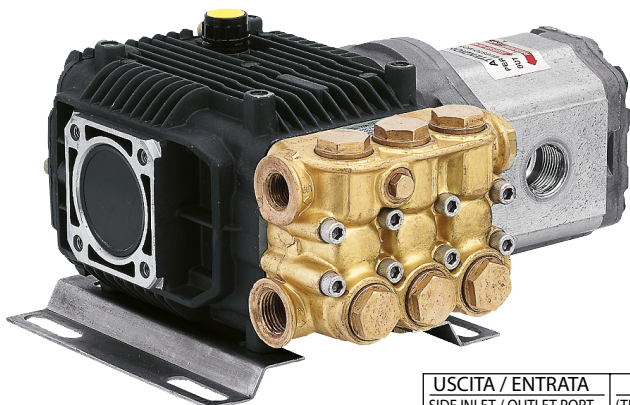

HYDRAULIC DRIVE



municipality

USCITA / ENTRATA SIDE INLET / OUTLET PORT	G 3/4" (THD 16 mm deep)	USCITA / ENTRATA SIDE INLET / OUTLET PORT	G 3/4" (THD 16 mm deep)
--	----------------------------	--	----------------------------

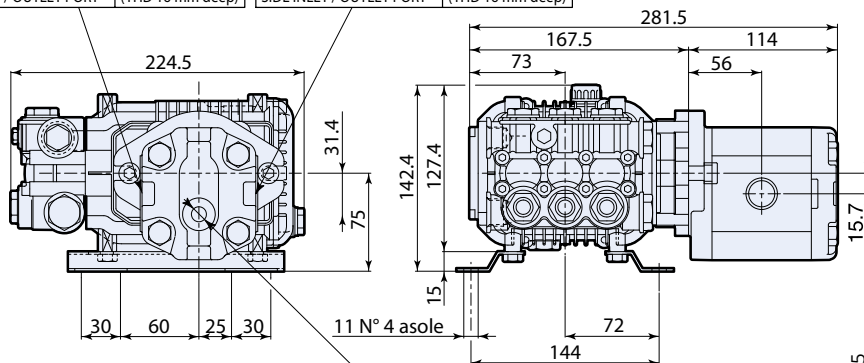

DRENAGGIO DRAIN PORT	G 1/4" (THD 13 mm deep)
-------------------------	----------------------------



testa in ottone
brass head



bielle in alluminio
connecting-rods in aluminium



motore idraulico
hydraulic drive

HYD - XM

MOD	COD	POMPA A PISTONI • HP PISTON PUMP					MOTORE IDRAULICO • HYDRAULIC MOTOR					NET		
		MAX	gpm	MAX	RPM	hp	SAUER DANFOSS	MAX	MAX	RPM	kg			
		l/min	gpm	bar	psi	N° giri/1'	hp	Type	Cod	cm ³	bar	l/min	N° giri/1'	kg
HYD-XM														
HYD-XM 15.15	21603	15	3,96	150	2200	1450	5,5	SNM2NN/019 BN06GAM1F5F5N	4769	19,2	105	29	1450	6,7

1788515





322 SERIES

RR
RRA
RRV
HRR



Corpo e coperchi in alluminio pressofuso.

Coperchio laterale con livello olio.
Coperchio posteriore con scarico olio.

Bielle in lega zinco- alluminio pressofuso o in bronzo.

Testa in ottone stampato. Possibilità di testa in ottone nichelata.

Pistoni in ceramica.

Pump body and back cover in pressure die-cast aluminium alloy.

Side cover incorporated with oil sight glass. Back cover incorporated with oil drain outlet.

Connecting rods in die-cast zinc-aluminium alloy. Bronze connecting rods available.

Pump head in forged brass. Nickel plated brass head available.

Ceramic pistons.

322 Series

POMPA ALBERO MASCHIO Solid shaft pump



				
idropulitrici pressure washers	processi industriali industrial processes	autolavaggio car wash	agricoltura agriculture	cantieri ed edilizia construction industry

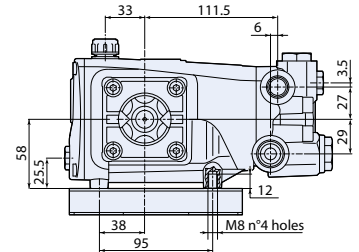
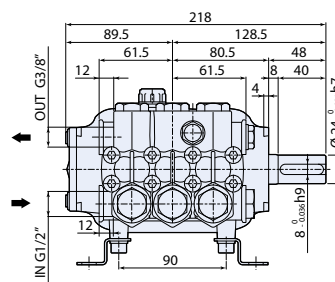
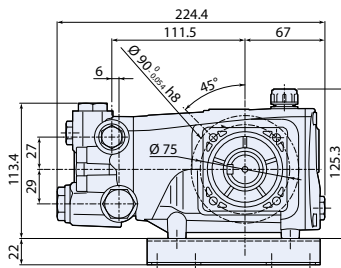

Piedi a richiesta.
Base on request.

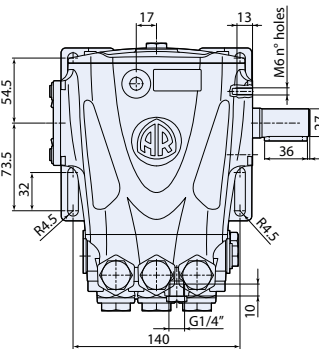









Model H

3228500

N version

Flangiatura compatibile XT N.
XT N flange type.

MOD	COD								
		l/min	gpm	bar	psi	hp	kW	N° giri/1'	kg
RR 1450rpm Nversion Ø24mm									
RR 13.20 N	23771	13	3,43	200	2900	7,5	5,5	1450	7,6
RR 15.15 N	23772	15	3,96	150	2200	5,5	4	1450	7,6
RR 15.20 N	23507	15	3,96	200	2900	7,5	5,5	1450	7,6
● RR 15.25 H N	● 24934	15	3,96	250	3600	10	7,5	1450	8
RR 18.12 N	23773	18	4,75	120	1740	5,5	4	1450	7,6
RR 18.16 N	23774	18	4,75	160	2300	7,5	5,5	1450	7,6
RRA 1750rpm Nversion Ø24mm									
RRA 3.5 G25 N	23779	13,2	3,5	170	2500	6	4,5	1750	7,6
RRA 4 G30 N	23780	15,1	4	205	3000	8,2	5,5	1750	7,6
● RRA 4 G36 H N	● 24937	15,1	4	250	3600	8,6	6,4	1750	8
RRA 5.5 G30 N	23781	20,8	5,5	205	3000	11	8,2	1750	7,6



● testa nichelata
nickel plated
brass head



● bielle in bronzo
connecting-rods
in bronze



testa in ottone
brass head



● bielle in alluminio
connecting-rods
in aluminium



322 Series

POMPA ALBERO CAVO Hollow shaft pump



idropulitrici
pressure
washers



processi
industriali
industrial
processes



autolavaggio
car wash



agricoltura
agriculture



cantieri ed
edilizia
construction
industry

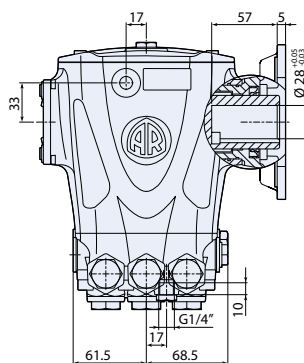
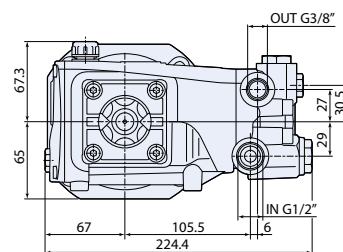
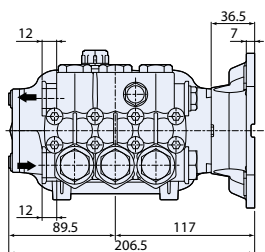
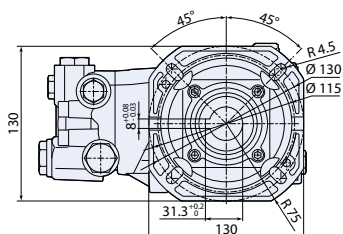

3228501

C version + flange

MOD	COD	MAX	MAX						
		l/min	gpm	bar	psi	hp	kW	N° giri/1'	kg
RR 1450rpm Cversion + flange Ø28mm									
RR 13.20 C + flange Ø 28 mm	23775	13	3,43	200	2900	7,5	5,5	1450	8
RR 15.15 C + flange Ø 28 mm	23776	15	3,96	150	2200	5,5	4	1450	8
RR 15.20 C + flange Ø 28 mm	23777	15	3,96	200	2900	7,5	5,5	1450	8
RR 18.16 C + flange Ø 28 mm	23778	18	4,75	160	2300	7,5	5,5	1450	8

Flangia per motori elettrici B14 Gr.100÷112 IEC34-7, 4 poli 50Hz. Flangia inclusa.
Flange for electric motor B14 100÷112 IEC34-7, 4 poles 50Hz. Flange included.



testa in
ottone
brass
head



bielle in
alluminio
connecting-rods
in aluminium

322 Series

POMPA ALBERO CAVO Hollow shaft pump

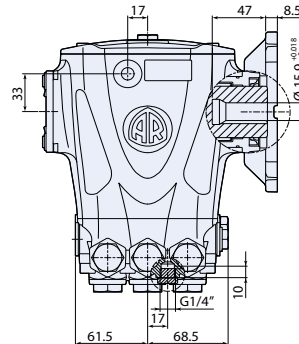
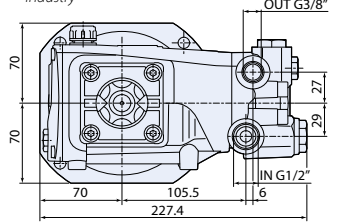
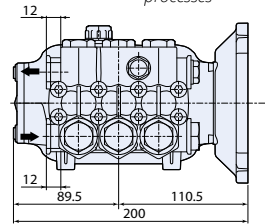
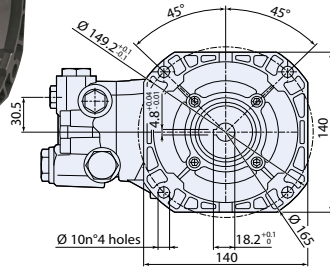

3228502

E version + flange

MOD	COD	MAX	MAX						
		l/min	gpm	bar	psi	hp	kW	N° giri/1'	kg
RRV 3400rpm	Eversion + flange Ø5/8"								
RRV 3 G25 E + flange Ø5/8"	23785	11,4	3	170	2500	5	3,7	3400	8
RRV 3.5 G20 E + flange Ø5/8"	23786	13,2	3,5	140	2000	4,8	3,6	3400	8

Flangia per motori elettrici NEMA 56-C, 2 poli 60Hz. Flangia inclusa.
Flange for electric motor NEMA 56-C, 2 poles 60Hz. Flange included.

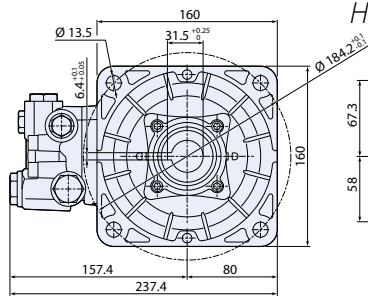
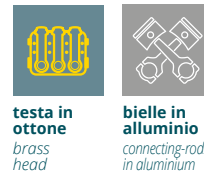

POMPA ALBERO CAVO Hollow shaft pump

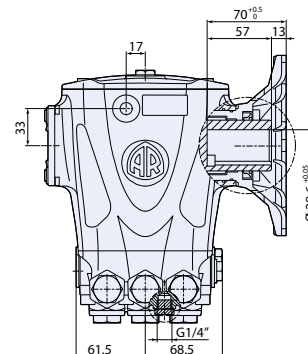
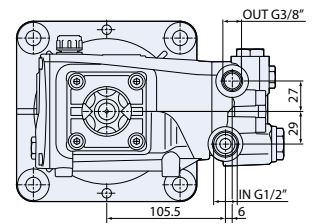
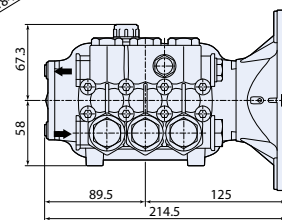

3228503



E version + flange

MOD	COD	MAX	MAX						
		l/min	gpm	bar	psi	hp	kW	N° giri/1'	kg
RRA 1750rpm	Eversion + flange Ø1"1/8								
RRA 3 G30 E + flange Ø1"1/8	23782	11,4	3	205	3000	6,2	4,6	1750	8
RRA 4 G30 E + flange Ø1"1/8	23783	15,1	4	205	3000	8,2	6,1	1750	8
RRA 5.5 G26 E + flange Ø1"1/8	23784	20,8	5,5	180	2600	10	7,5	1750	8

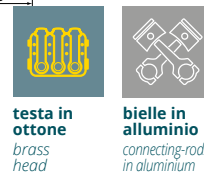

Flangia per motori elettrici NEMA 182-184, 4 poli 60 Hz. Flangia inclusa.
Flange for electric motor NEMA 182-184, 4 poles 60 Hz. Flange included.



322 Series

POMPA ALBERO CAVO Hollow shaft pump



idropultrici
pressure
washers

processi
industriali
industrial
processes

agricoltura
agriculture

cantieri ed
edilizia
construction
industry

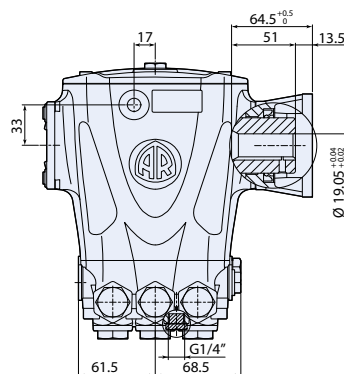
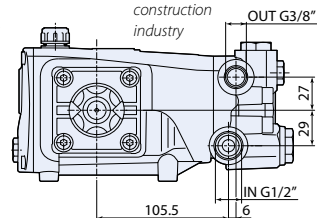
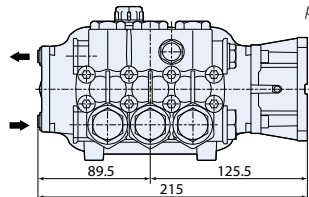
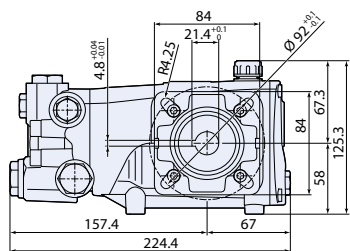

3228504

D version + flange

MOD	COD	MAX	MAX						
		l/min	gpm	bar	psi	hp	kW	N° giri/1'	kg
RRV 3400rpm Dversion + flange Ø 3/4"									
RRV 3 G27 D + flange Ø 3/4"	23787	11,4	3	186	2700	5,5	4	3400	8
RRV 3.5 G25 D + flange Ø 3/4"	23788	13,2	3,5	170	2500	6	4,5	3400	8



testa in
ottone
brass
head



bielle in
alluminio
connecting-rods
in aluminium

Flangia per motori scoppio Ø 3/4" SAE J609a. Flangia inclusa.
For gasoline engine flange Ø 3/4" SAE J609a. Flange included.

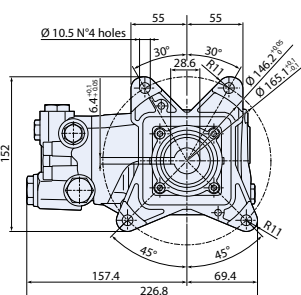

Model H

POMPA ALBERO CAVO Hollow shaft pump

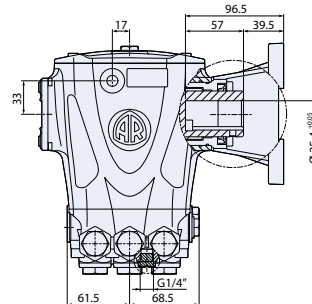
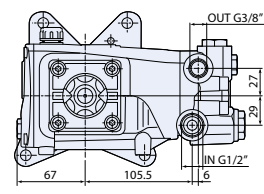
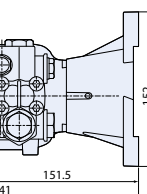

3228505



idropultrici
pressure
washers

processi
industriali
industrial
processes

agricoltura
agriculture

cantieri ed
edilizia
construction
industry

D version + flange

MOD	COD	MAX	MAX						
		l/min	gpm	bar	psi	hp	kW	N° giri/1'	kg
RRV 3400rpm Dversion + flange Ø 1"									
RRV 3 G30 D + flange Ø 1"	23789	11,4	3	205	3000	6,2	4,6	3400	8
RRV 3 G36 D + flange Ø 1"	23790	11,4	3	250	3600	7,4	5,5	3400	8
RRV 3.5 G36 D + flange Ø 1"	23791	13,2	3,5	250	3600	8,6	6,4	3400	8
RRV 4 G36 D + flange Ø 1"	23508	15,1	4	250	3600	9,9	7,4	3400	8



testa
nichelata
nickel plated
brass head



bielle in
bronzo
connecting-rods
in bronze



testa in
ottone
brass
head



bielle in
alluminio
connecting-rods
in aluminium

Flangia per motori scoppio Ø 1" SAE J609a.
Flangia inclusa.
For gasoline engine flange Ø 1" SAE J609a. Flange included.



idropultrici
pressure
washers



processi industriali
industrial
processes



autolavaggio
car wash



agricoltura
agriculture





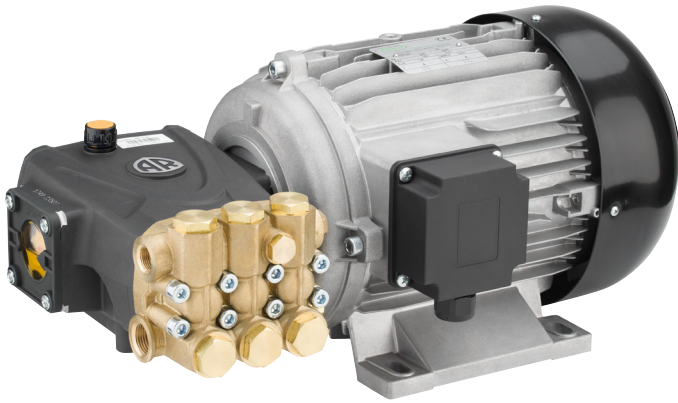

cantieri ed edilizia
construction
industry

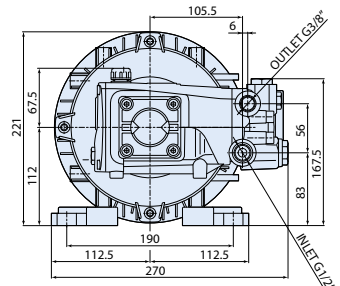
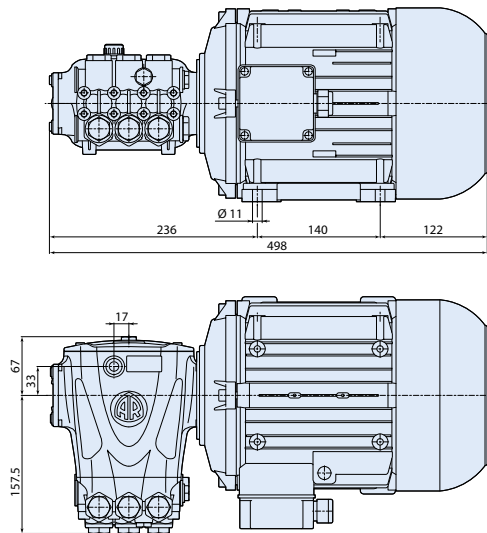

GR. 112 motor hollow shaft



3228509

MOD	COD	 MAX	 MAX								
	3 ~	l/min	gpm	bar	psi	hp	kW	N° giri/1'	V 3-50Hz	Gr.	kg
HRR 1450rpm											
HRR 15.15 ET	23978	15	3,96	150	2200	5,5	4	1450	230/400	112	24
HRR 15.20 ET	23979	15	3,96	200	2900	7,5	5,5	1450	230/400	112	33
HRR 18.16 ET	23980	18	4,75	160	2300	7,5	5,5	1450	230/400	112	33



testa in ottone
brass
head



bielle in alluminio
connecting-rods
in aluminium



3~50Hz
frequenza motore
motor
frequency

228 SERIES

RK
RKA
RKV
JK
JKA

RHW
RCW
HRK
RK+F38
HYD-RK



Corpo e coperchi in alluminio pressofuso.

Coperchio posteriore con livello olio e scarico olio. Possibilità di ulteriore livello olio laterale.

Cuscinetti a rulli conici.

Bielle in lega zinco-alluminio oppure in bronzo.

Testa in ottone stampato o in ottone nichelato.

Pistoni in ceramica.

Pump body and back cover in pressure die-cast aluminium alloy.

Back cover incorporated with oil sight glass and oil drain outlet. Possibility of further lateral oil sight glass.

Tapered roller bearings.

Connecting rods in zinc-aluminium alloy. Bronze connecting rods available.

Pump head in forged brass or nickel-plated brass.

Ceramic pistons.

228 Series

POMPA ALBERO MASCHIO Solid shaft pump



idropultrici
pressure washers

processi industriali
industrial processes

autolavaggio
car wash

agricoltura
agriculture

municipality



cantieri ed edilizia
construction industry



Model H

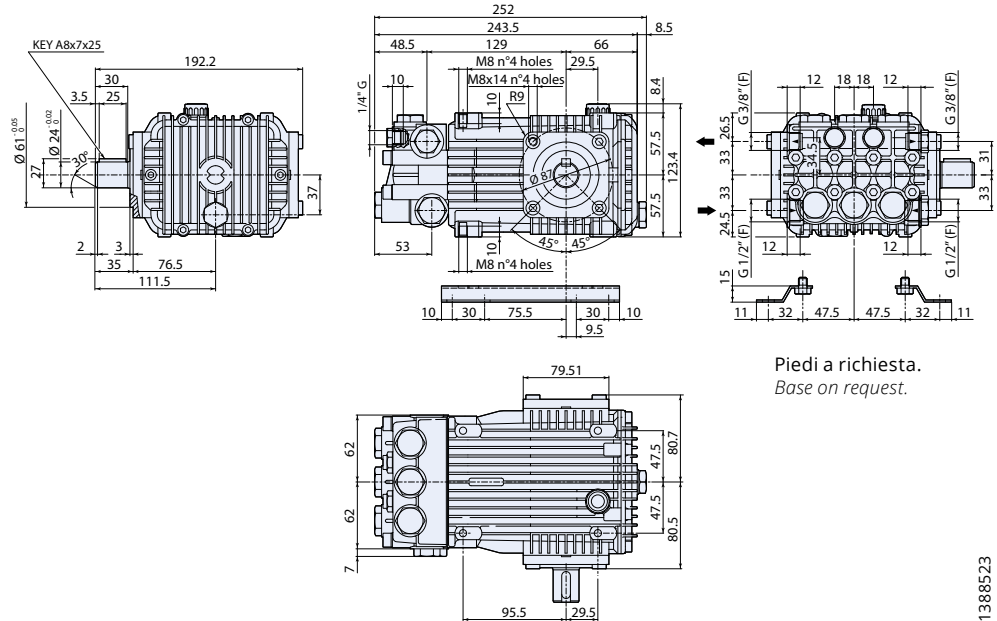

Piedi a richiesta.
Base on request.

N version

MOD	COD	MAX	gpm	MAX	bar	psi	hp	kW	N° giri/1'	KG NET
RK 1450rpm Nversion Ø24mm										
RK 11.14 N	20630	11	2,90	140	2000	4	3	1450	9	
● RK 11.20 H N	20631	11	2,90	200	2900	5,5	4	1450	9	
● RK 11.25 H N	● 20632	11	2,90	250	3600	7,5	5,5	1450	9,5	
RK 13.17 N	20634	13	3,43	170	2500	5,5	4	1450	9	
● RK 13.20 H N	20635	13	3,43	200	2900	7,5	5,5	1450	9	
RK 14.16 N	20636	14	3,70	160	2300	5,5	4	1450	9	
RK 15.15 N	20637	15	3,96	150	2200	5,5	4	1450	9	
● RK 15.20 H N	20638	15	3,96	200	2900	7,5	5,5	1450	9	
● RK 15.25 H N	● 20639	15	3,96	250	3600	10	7,5	1450	9,5	
● RK 15.28 H N	● 20640	15	3,96	275	4000	11	8,2	1450	9,5	
RK 18.12 N	20641	18	4,75	120	1740	5,5	4	1450	9	
● RK 18.20 H N	● 20643	18	4,75	200	2900	10	7,5	1450	9,5	
● RK 18.28 H N	● 21467	18	4,75	275	4000	15	11	1450	9,5	
RK 21.10 N	20644	21	5,55	100	1450	5,5	4	1450	9	
● RK 21.15 H N	20645	21	5,55	150	2200	7,5	5,5	1450	9	
● RK 21.20 H N	● 21129	21	5,55	200	2900	10	7,5	1450	9,5	
RK 24.10 N	23818	24	6,34	100	1450	6,3	4,7	1450	9	
● RK 24.15 H N	● 23819	24	6,34	150	2200	9,4	7,2	1450	9,5	



● testa nichelata
nickel plated brass head



● bielle in bronzo
connecting-rods in bronze



● testa in ottone
brass head



● bielle in alluminio
connecting-rods in aluminum

1388523



228 series

POMPA ALBERO MASCHIO Solid shaft pump



idropultrici
pressure
washers



processi
industriali
industrial
processes



autolavaggio
car wash



agricoltura
agriculture



municipality



cantieri ed
edilizia
construction
industry

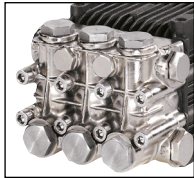

Model H

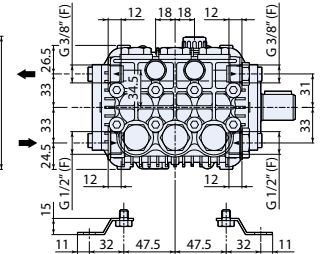
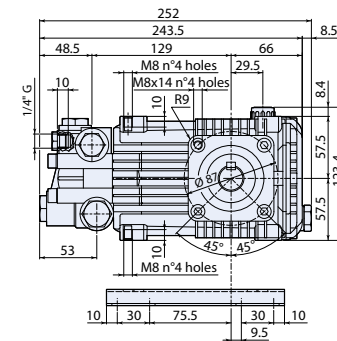
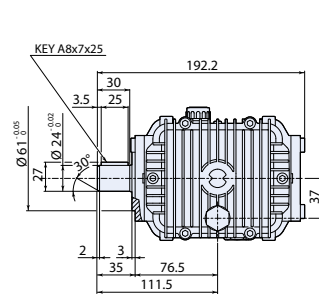

Piedi a richiesta.
Base on request.

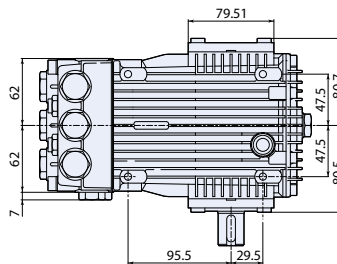

1368523

N version

MOD	COD	MAX l/min	MAX gpm	MAX bar	MAX psi	MAX hp	MAX kW	MAX N° giri/1'	MAX kg
RKA 1750rpm Nversion Ø24mm									
RKA 3.5 G25 N	20659	13,2	3,5	170	2500	5	3,6	1750	9
● RKA 3.5 G40 H N	● 20661	13,2	3,5	275	4000	10	7,5	1750	9,5
● RKA 4 G30 H N	● 20665	15,1	4	205	3000	7,5	5,5	1750	9,5
● RKA 4 G40 H N	● 20667	15,1	4	275	4000	11	8,2	1750	9,5
RKA 4.5 G17 N	20668	17	4,5	115	1700	5	3,6	1750	9
● RKA 4.5 G30 H N	● 20670	17	4,5	205	3000	10	7,5	1750	9,5
● RKA 4.5 G40 H N	● 21130	17	4,5	275	4000	12,5	9,2	1750	9,5
RKA 5.5 G13 N	20671	20,8	5,5	90	1300	5	3,6	1750	9
● RKA 5.5 G20 H N	20672	20,8	5,5	140	2000	7,5	5,5	1750	9
● RKA 5.5 G30 H N	● 21131	20,8	5,5	205	3000	11	8,2	1750	9,5
RKA 6.5 G13 N	20674	25	6,6	90	1300	6	4,4	1750	9
● RKA 6.5 G20 H N	● 20675	25	6,6	140	2000	9	6,8	1750	9,5
RKA 7 G13 N	20676	27	7,1	90	1300	6,5	4,7	1750	9
● RKA 7 G20 H N	● 20677	27	7,1	140	2000	10	7,5	1750	9,5



● testa
nichelata
nickel plated
brass head



● bielle in
bronzo
connecting-rods
in bronze



● testa in
ottone
brass
head



● bielle in
alluminio
connecting-rods
in aluminium

228 Series

POMPA ALBERO CAVO Hollow shaft pump



idropultrici
pressure
washers



processi industriali
industrial
processes



autolavaggio
car wash



agricoltura
agriculture



municipality



cantieri ed edilizia
construction
industry

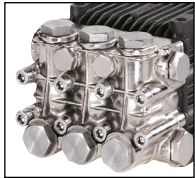

● Model H

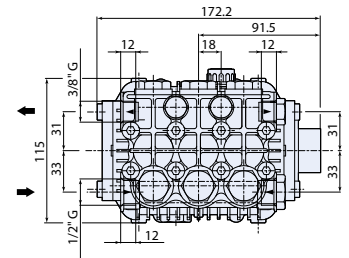
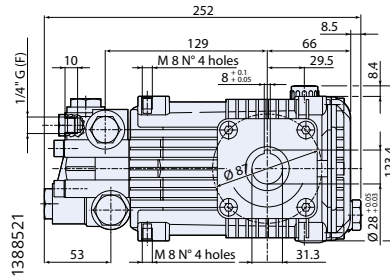

C version

MOD	COD	MAX		MAX				N° giri/1'	KG NET
		l/min	gpm	bar	psi	hp	kW		
RK 1450rpm Cversion Ø28mm									
● RK 11.20 H C	20647	11	2,90	200	2900	5,5	4	1450	9
RK 13.12 C	20648	13	3,43	120	1740	4	3	1450	9
RK 13.17 C	20649	13	3,43	170	2500	5,5	4	1450	9
● RK 13.20 H C	20650	13	3,43	200	2900	7,5	5,5	1450	9
RK 14.16 C	20651	14	3,70	160	2300	5,5	4	1450	9
RK 15.15 C	20652	15	3,96	150	2200	5,5	4	1450	9
● RK 15.20 H C	20653	15	3,96	200	2900	7,5	5,5	1450	9
RK 18.12 C	20654	18	4,75	120	1740	5,5	4	1450	9
● RK 18.16 H C	20655	18	4,75	160	2300	7,5	5,5	1450	9
RK 21.10 C	20656	21	5,55	100	1450	5,5	4	1450	9
● RK 21.15 H C	20657	21	5,55	150	2200	7,5	5,5	1450	9



● **testa nichelata**
nickel plated
brass head



testa in ottone
brass
head



bielle in alluminio
connecting-rods
in aluminium

F16 flange for electric motor B14 100+112 IEC34-7, 4 poles 50Hz. Flange not included.
Flangia F16 per motori elettrici B14 Gr.100+112 IEC34-7, 4 poli 50Hz. Flangia non inclusa.



228 series

POMPA ALBERO CAVO Hollow shaft pump



idropulitrici
pressure
washers



processi
industriali
industrial
processes



autolavaggio
car wash



agricoltura
agriculture



municipality



cantieri ed
edilizia
construction
industry

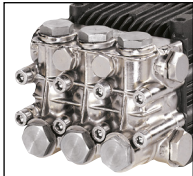

Model H

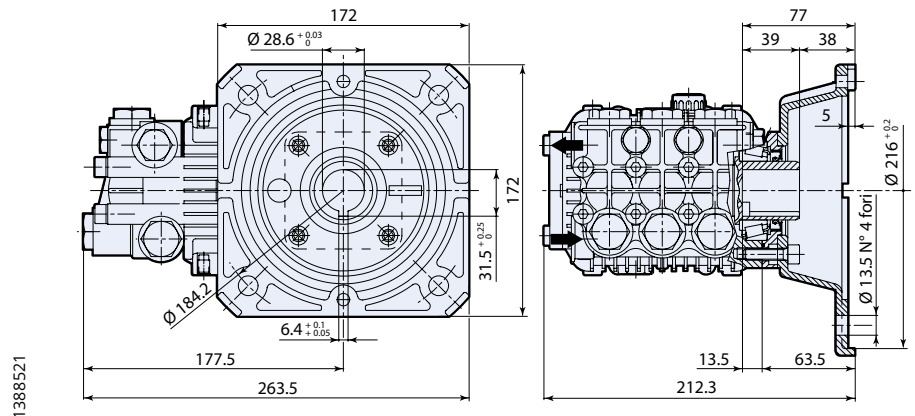

Flangia F17 fornita a richiesta.
F17 flange on request.

E version

MOD	COD	MAX		MAX				KG	
		l/min	gpm	bar	psi	hp	kW	N°	NET
								giri/1'	kg
RKA 1750rpm Eversion Ø1" 1/8									
RKA 3.5 G25 E	20678	13,2	3,5	170	2500	5	3,6	1750	9
● RKA 3.5 G30 H E	● 20679	13,2	3,5	205	3000	7,5	5,5	1750	9,5
RKA 4 G20 E	20680	15,1	4	140	2000	5	3,6	1750	9
● RKA 4 G30 H E	● 20681	15,1	4	205	3000	7,5	5,5	1750	9,5
RKA 5.5 G13 E	20682	20,8	5,5	90	1300	5	3,6	1750	9
RKA 6.5 G13 E	● 20683	25	6,6	90	1300	6	4,4	1750	9
● RKA 6.5 G20 H E	● 20684	25	6,6	140	2000	9	6,8	1750	9,5
RKA 7 G13 E	20685	27	7,1	90	1300	6,5	4,7	1750	9
● RKA 7 G20 H E	● 20686	27	7,1	140	2000	10	7,5	1750	9,5



● testa
nichelata
nickel plated
brass head



● bielle in
bronzo
connecting-rods
in bronze



● testa in
ottone
brass
head



● bielle in
alluminio
connecting-rods
in aluminium

Flangia F17 per motori elettrici NEMA 182-184,
4 poli 60Hz. Flangia non inclusa.
F17 flange for electric motor NEMA 182-184,
4 poles 60Hz. Flange not included.

228 Series

POMPA ALBERO CAVO Hollow shaft pump



Model H



idropultrici
pressure
washers



processi industriali
industrial
processes



autolavaggio
car wash



agricoltura
agriculture



municipality



cantieri ed edilizia
construction
industry

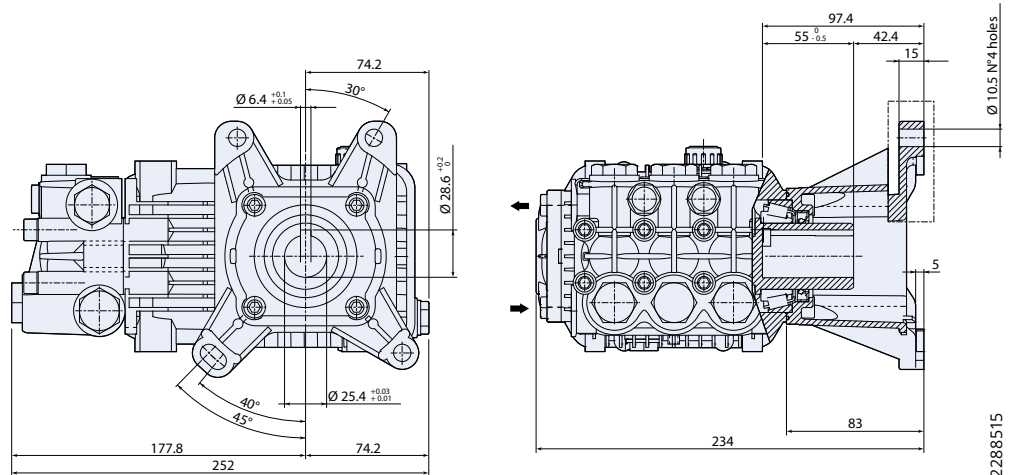

D version + F41

MOD	COD	MAX	MAX	MAX	MAX	MAX	MAX	N° giri/1'	NET
		l/min	gpm	bar	psi	hp	kW		kg
RKV 3400rpm Dversion + F41 Ø1"									
RKV 3.5 G25 D + F41	20693	13,2	3,5	170	2500	5	3,6	3400	10
●RKV 3.5 G30 H D + F41	● 20694	13,2	3,5	205	3000	5	3,6	3400	10,5
●RKV 3.5 G40 H D + F41	21132	13,2	3,5	275	4000	10	7,5	3400	10
RKV 4 G30 D + F41	● 20697	15,1	4	205	3000	7,5	5,5	3400	10,5
●RKV 4 G35 H D + F41	● 20699	15,1	4	240	3500	7,5	5,5	3400	10,5
●RKV 4 G40 H D + F41	● 21133	15,1	4	275	4000	11	8,2	3400	10,5
●RKV 4.5 G40 H D + F41	● 21134	17	4,5	275	4000	12	8,7	3400	10,5
●RKV 5.5 G40 H D + F41	● 21135	20,8	5,5	275	4000	15	11	3400	10,5



● **testa nichelata**
nickel plated
brass head



● **bielle in bronzo**
connecting-rods
in bronze



● **testa in ottone**
brass
head



● **bielle in alluminio**
connecting-rods
in aluminium

Flangia F41 per motori scoppio Ø 1" SAE J609a.
Flangia inclusa.
Flange F41 for gasoline engine Ø 1" SAE J609a.
Flange included.

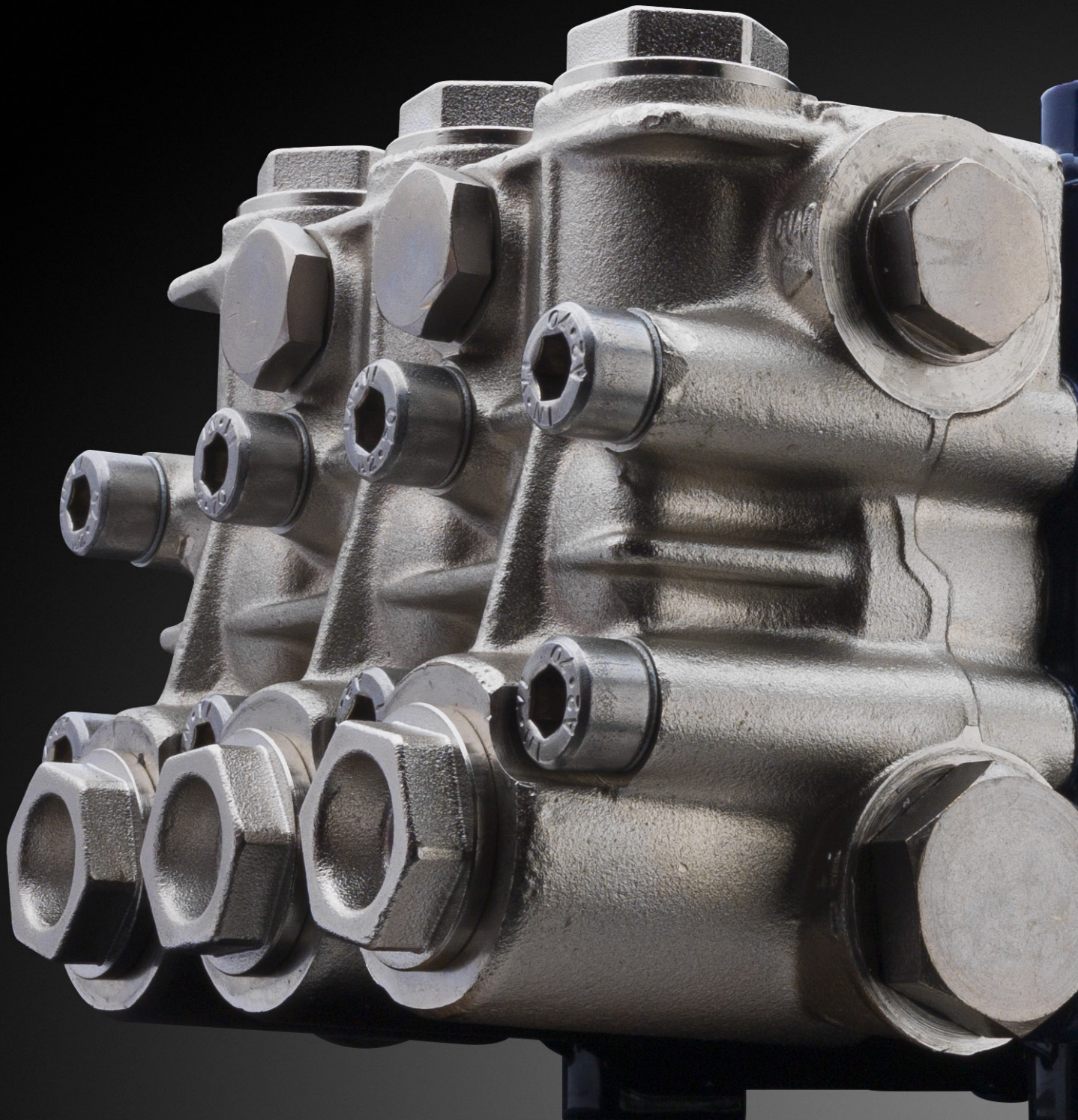

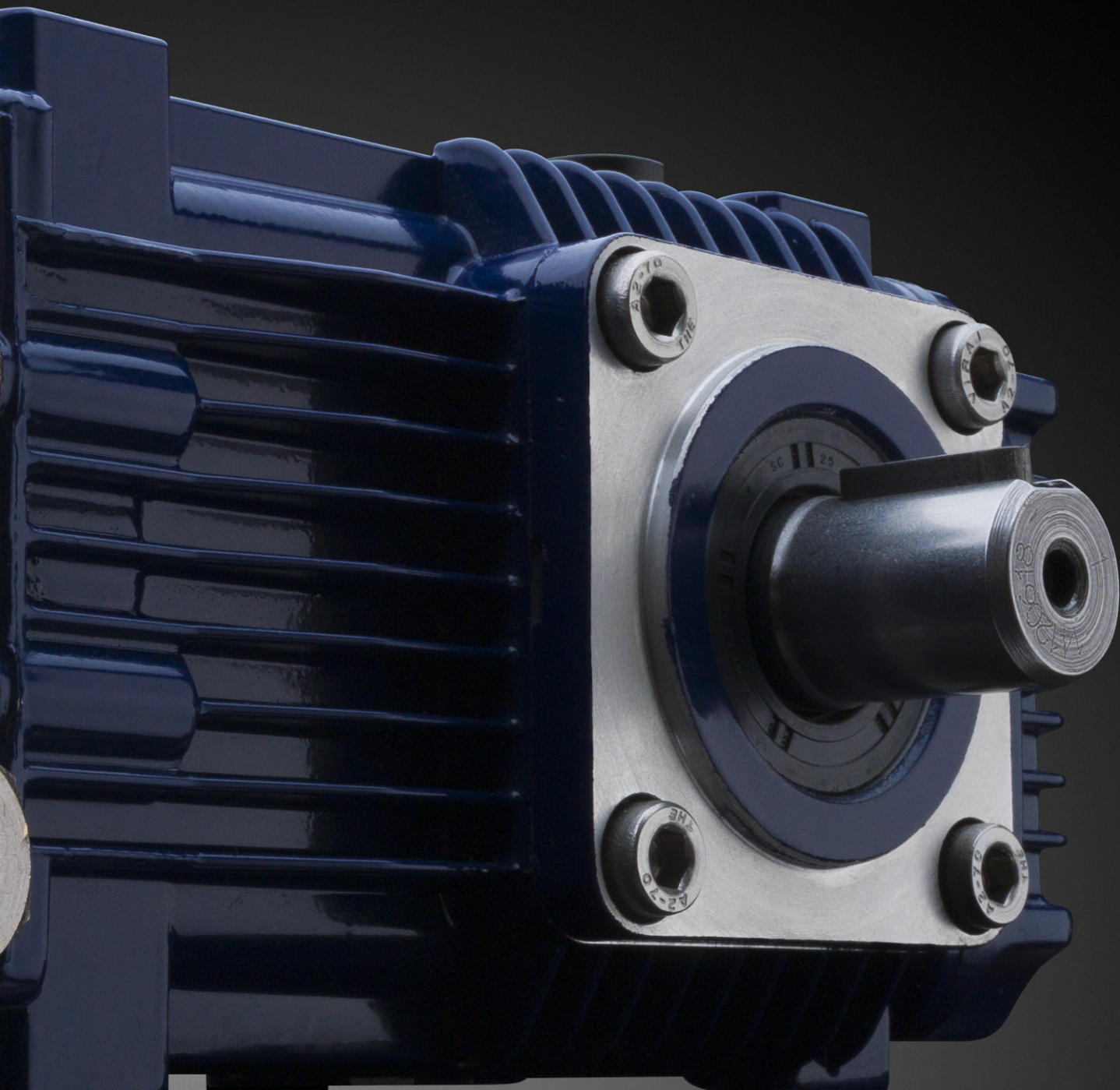

Premium Series

LOW MAINTENANCE
HIGH EFFICIENCY



228 Series

PREMIUM SERIES

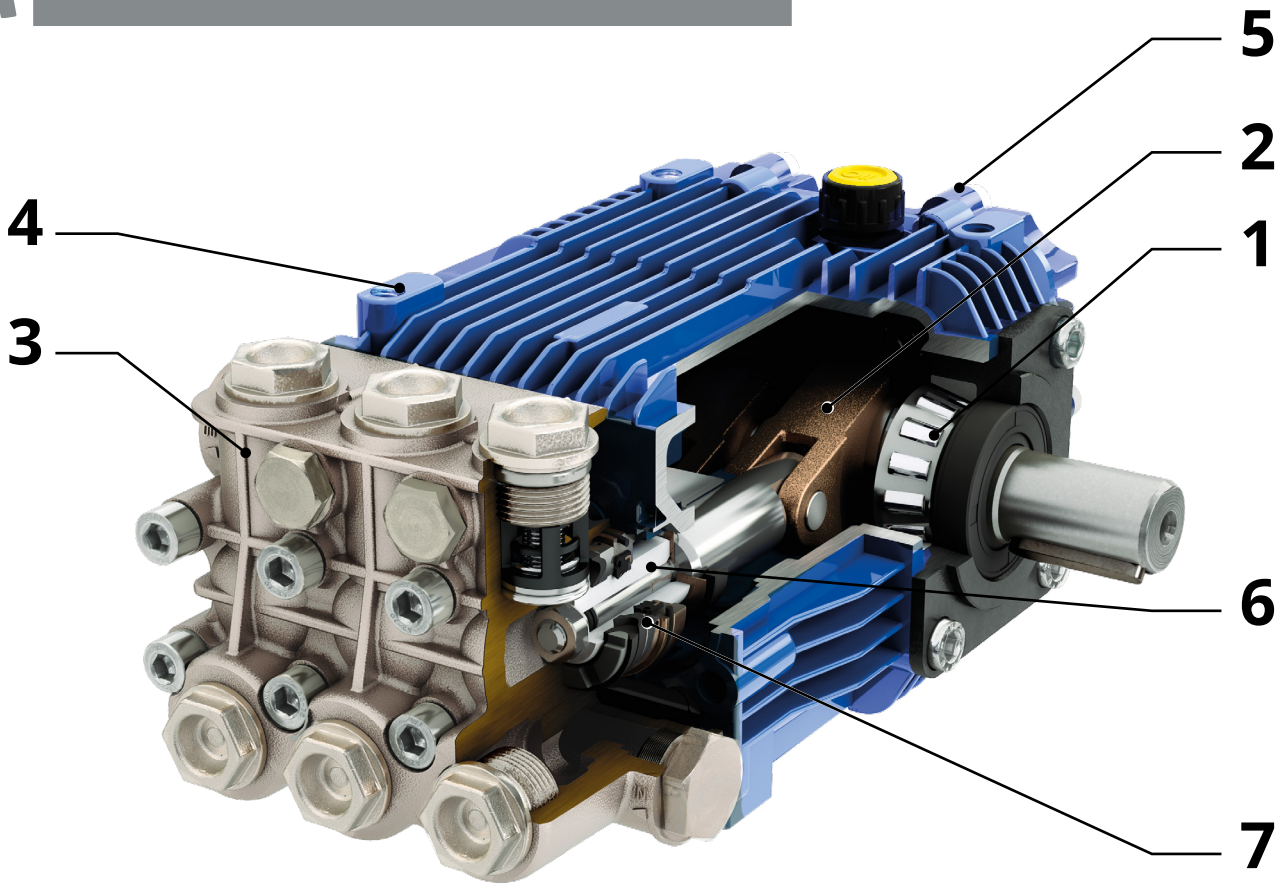

- 1** Cuscinetti a rulli conici di livello Premium.
- 2** Bielle in speciale lega in bronzo.
- 3** Testa in ottone nichelato per una maggiore resistenza agli agenti chimici.
- 4** Corpo in lega di alluminio pressofuso con trattamento di verniciatura a polvere per una maggiore resistenza alla corrosione.
- 5** Coperchio posteriore maggiorato per contenere una maggiore quantità di olio e per garantire quindi una migliore lubrificazione.
Tappo scarico olio magnetico per raccolta di particelle metalliche provenienti dall'usura delle parti meccaniche in movimento.

- 6** Pistoni in ceramica.
- 7** Doppia guarnizione Long Life per una durata maggiore e prevenire perdite di acqua.

- 1** *Premium quality tapered roller bearings.*
- 2** *Connecting rods in a special bronze alloy.*
- 3** *Nickel-plated brass pump head for added protection against chemicals.*
- 4** *Pump body in pressure die-cast aluminium alloy with a paint treatment that increases the corrosion resistance.*
- 5** *Extended back cover to contain a larger amount of oil and ensure a better lubrication.*
Magnetic discharge oil cap to attract all microscopic metal particles arising from heavy duty usage.

- 6** *Ceramic pistons.*
- 7** *Long life double sealing system to ensure longer duration and prevent water leakage.*



Premium Series

LOW MAINTENANCE
HIGH EFFICIENCY

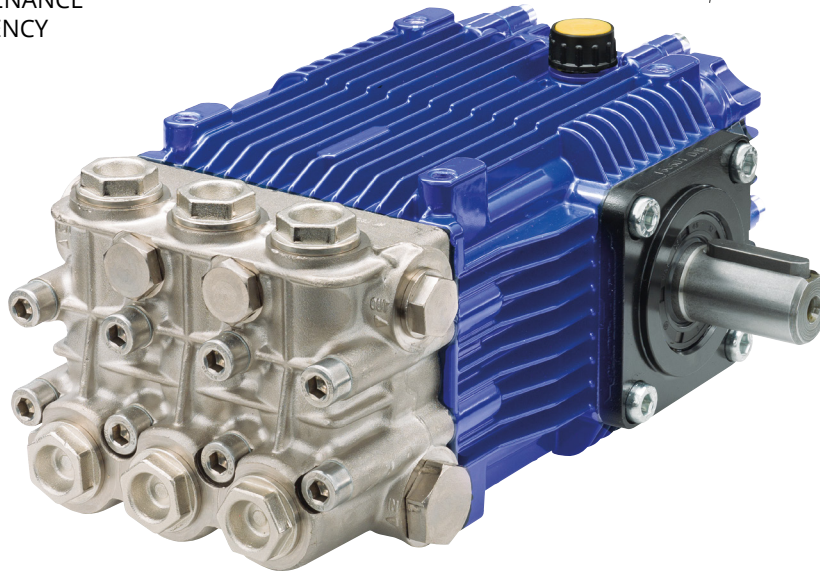

CAR WASH

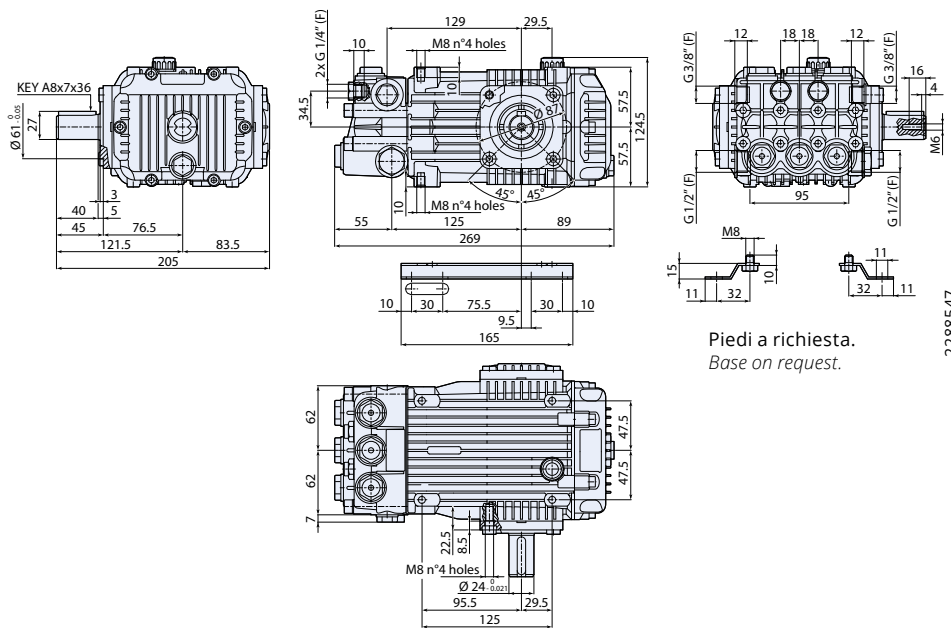

Piedi a richiesta.
Base on request.

2288547

N version

MOD	COD	MAX	MAX						
		l/min	gpm	bar	psi	hp	kW	N° giri/1'	kg
JK 1450rpm Nversion Ø24mm									
JK 11.20 H N	26781	11	2,9	200	2900	5,5	4	1450	9,5
JK 12.20 H N	26782	12	3,2	200	2900	5,5	4	1450	9,5
JK 13.12 H N	26359	13	3,43	120	1740	5,5	4	1450	9,5
JK 13.20 H N	26783	13	3,43	200	2900	7,5	5,5	1450	9,5
JK 15.15 H N	26169	15	3,96	150	2200	5,5	4	1450	9,5
JK 15.20 H N	23964	15	3,96	200	2900	7,5	5,5	1450	9,5
JK 18.16 H N	26779	18	4,75	160	2300	7,5	5,5	1450	9,5
JK 21.15 H N	26780	21	5,55	150	2200	7,5	5,5	1450	9,5
JKA 1750rpm Nversion Ø24mm									
JKA 4 G30 H N	26531	15,1	4	205	3000	7,5	5,5	1750	9,5

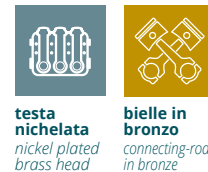



228 series

POMPA ALBERO MASCHIO Solid shaft pump



idropulitrici
pressure
washers



processi
industriali
industrial
processes



autolavaggio
car wash



agricoltura
agriculture



cantieri ed
edilizia
construction
industry

CAR WASH

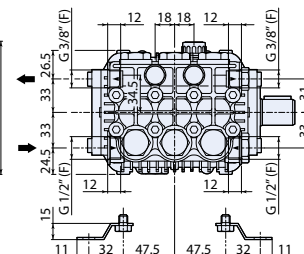
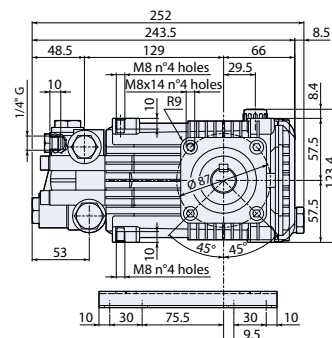
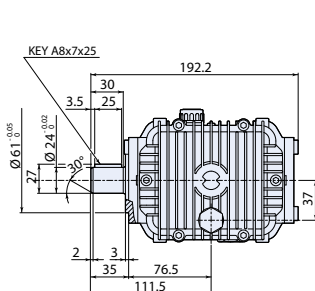
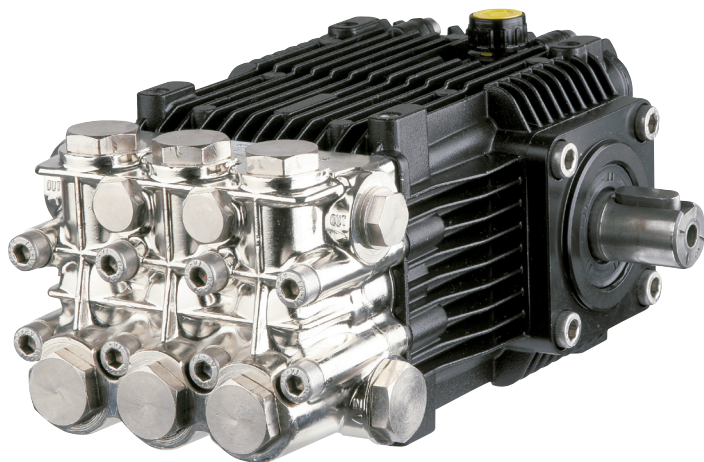

Piedi a richiesta.
Base on request.

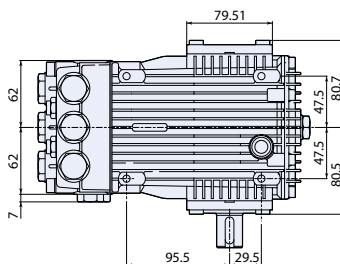

1388523

N version

MOD	COD	MAX	MAX	MAX	MAX	MAX	MAX	MAX	MAX
		l/min	gpm	bar	psi	hp	kW	N° giri/1'	kg
RCW 950rpm Nversion Ø24mm									
RCW 10.15 N	20825	10	2,64	150	2200	4	3	950	9,5
RCW 15.14 N	20826	15	3,96	140	2000	5,5	4	950	9,5
RCW 1450rpm Nversion Ø24mm									
RCW 11.10 N	20827	11	2,90	100	1450	3	2,2	1450	9,5
RCW 15.15 N	20828	15	3,96	150	2200	5,5	4	1450	9,5
RCW 15.20 N	20833	15	3,96	200	2900	7,5	5,5	1450	9,5



testa
nichelata
nickel plated
brass head



bielle in
bronzo
connecting-rods
in bronze



autolavaggio
car wash municipality

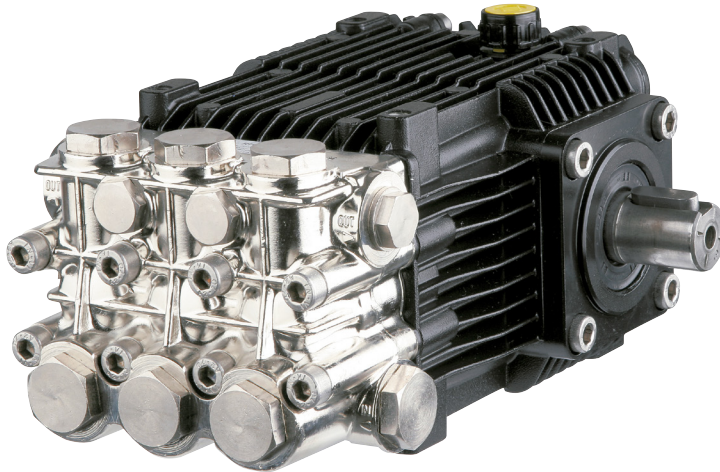

HOT WATER 85°C

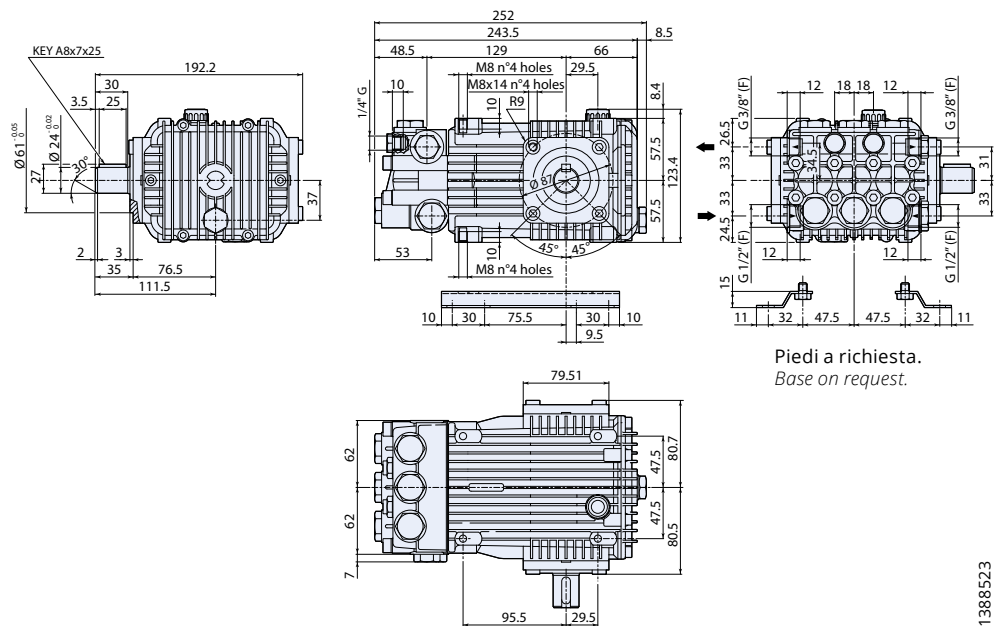

Piedi a richiesta.
Base on request.

1388523

N version

MOD	COD	MAX	MAX	MAX	MAX	MAX	MAX	MAX	NET
		l/min	gpm	bar	psi	hp	kW	N° giri/1'	kg
RHW 950rpm Nversion Ø24mm									
RHW 10.15 N	22345	10	2,64	150	2200	4	3	950	9
RHW 1450rpm Nversion Ø24mm									
RHW 13.12 N	22342	13	3,43	120	1740	4	3	1450	9
RHW 13.17 N	22343	13	3,43	170	2500	5,5	4	1450	9
RHW 15.15 N	22344	15	3,96	150	2200	5,5	4	1450	9



testa
nichelata
nickel plated
brass head



MAX
85°



PTFE
guarnizioni
in PTFE
PTFE gasket
sealing



bielle in
bronzo
connecting-rods
in bronze



228 Series

ELECTRIC MOTOR-PUMP UNITS



idropulitrici
pressure washers



processi industriali
industrial processes



autolavaggio
car wash



agricoltura
agriculture



industria alimentare
food industry



cantieri ed edilizia
construction industry

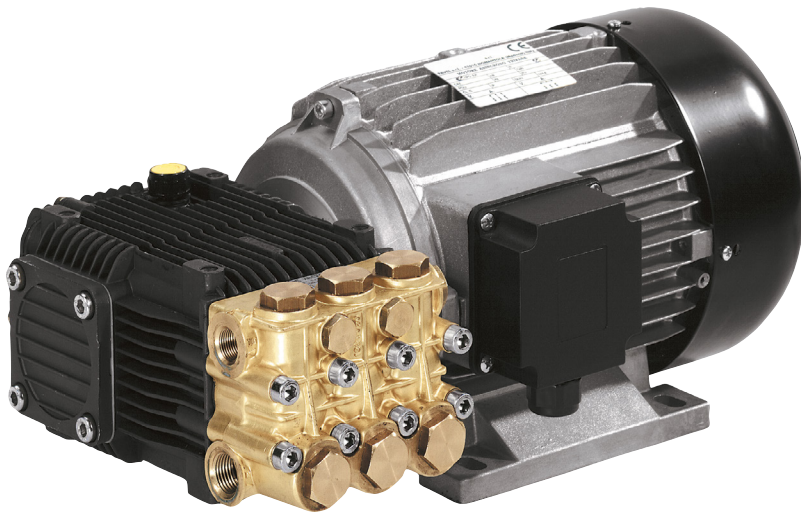

GR. 112 motor hollow shaft



Model H

2288501

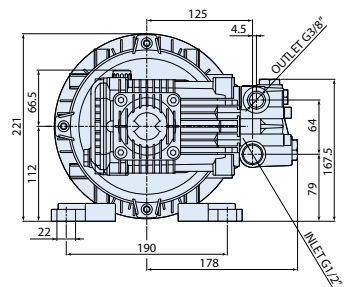
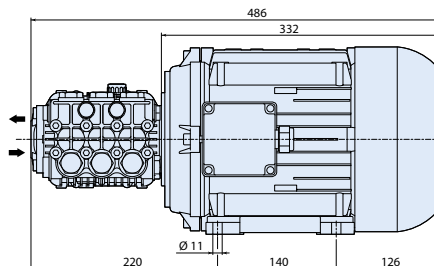

GR. 132 S motor hollow shaft

2288526

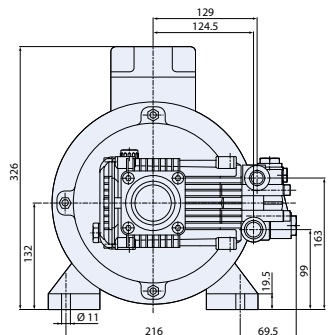
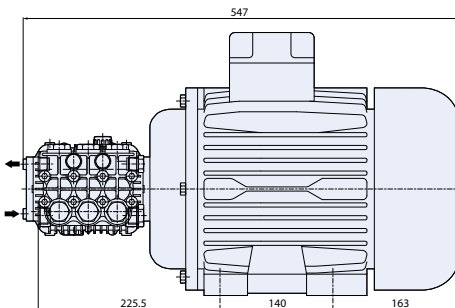

MOD	COD	MAX		MAX						KG NET	
	3 ~	l/min	gpm	bar	psi	hp	kW	N° giri/1'	V 3-50Hz	Gr.	kg
HRK 1450rpm											
● HRK 13.20 H ET	20859	13	3,43	200	2900	7,5	5,5	1450	230/400	112	41
HRK 14.16 ET	20860	14	3,70	160	2300	5,5	4	1450	230/400	112	32
HRK 15.15 ET	20861	15	3,96	150	2200	5,5	4	1450	230/400	112	32
● HRK 15.20 H ET	20862	15	3,96	200	2900	7,5	5,5	1450	230/400	112	41
● HRK 15.25 H ET	● 20863	15	3,96	250	3600	10	7,5	1450	230/400	132 S	56
● HRK 18.16 H ET	20865	18	4,75	160	2300	7,5	5,5	1450	230/400	112	41
HRK 21.10 ET	20866	21	5,55	100	1450	5,5	4	1450	230/400	112	32
● HRK 21.15 H ET	20867	21	5,55	150	2200	7,5	5,5	1450	230/400	112	41
● HRK 21.20 H ET	● 20868	20	5,55	190	2600	10	7,5	1450	230/400	132 S	56



● **testa nichelata**
nickel plated brass head



● **bielle in bronzo**
connecting-rods in bronze



● **testa in ottone**
brass head



● **bielle in alluminio**
connecting-rods in aluminum



● **3~50Hz**
frequenza motore
motor frequency

228 Series

HYDRAULIC DRIVE



municipality

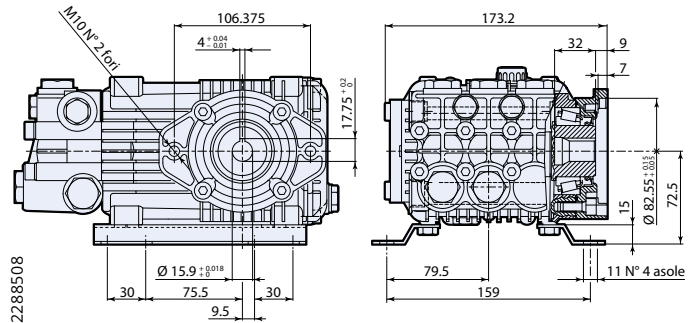

Piedi a richiesta.
Base on request.

RK + F38

MOD	COD	MAX	MAX	MAX	MAX					NET
		l/min	gpm	bar	psi	hp	kW	N° giri/1'	kg	
RK 1450 rpm + F 38										
RK 15.15 + F38	21599	15	3,96	150	2200	5,5	4	1450	9,2	
RK 15.20 + F38	21600	15	3,96	200	2900	7,5	5,5	1450	9,2	
RK 21.15 + F38	22086	21	5,55	150	2200	7,5	5,5	1450	9,2	



testa in ottone
brass head



bielle in alluminio
connecting-rods in aluminium

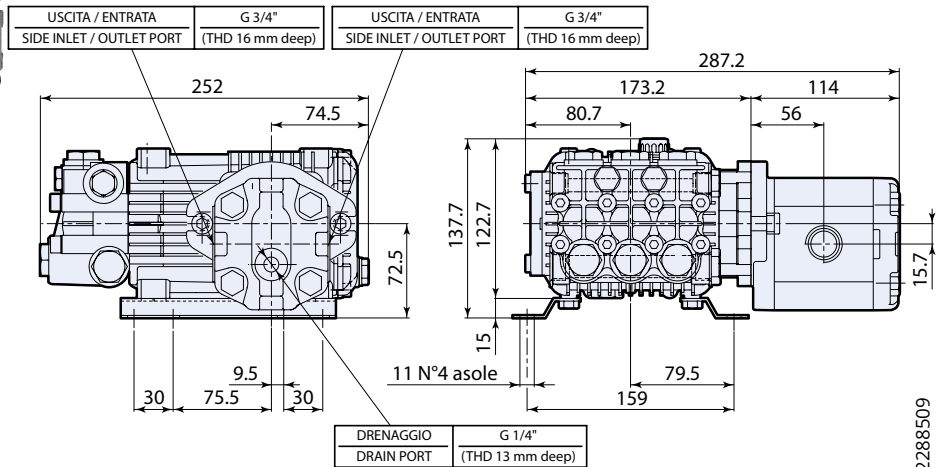

2288509



municipality



antincendio
fire fighting



testa in ottone
brass head



bielle in alluminio
connecting-rods in aluminium



motore idraulico
hydraulic drive

HYD - RK

MOD	COD	POMPA A PISTONI • HP PISTON PUMP						MOTORE IDRAULICO • HYDRAULIC MOTOR						
		MAX	MAX	MAX	MAX	RPM		SAUER DANFOSS*			MAX	MAX	RPM	NET
		l/min	gpm	bar	psi	N° giri/1'	hp	Type	Cod	cm ³	bar	l/min	N° giri/1'	kg
HYD-RK														
HYD-RK 15.15	21604	15	3,96	150	2200	1450	5,5	SNM2NN/019 BN06GAM1F5F5N	4769	19,2	105	29	1450	12,5
HYD-RK 15.20	21605	15	3,96	200	2900	1450	7,5	SNM2NN/019 BN06GAM1F5F5N	4769	19,2	140	29	1450	12,5
HYD-RK 21.15	22087	21	5,55	150	2200	1450	7,5	SNM2NN/019 BN06GAM1F5F5N	4769	19,2	150	29	1450	12,5

*) A richiesta disponibili motori idraulici Casappa - Marzocchi.
On request available Hydraulic Motor type: Casappa - Marzocchi.



228 Series

GASOLINE MOTOR-PUMP UNITS



idropulitrici
pressure
washers



processi industriali
industrial
processes



autolavaggio
car wash



agricoltura
agriculture



cantieri ed edilizia
construction
industry



RKV 3400 rpm Direct Drive
from Honda engine

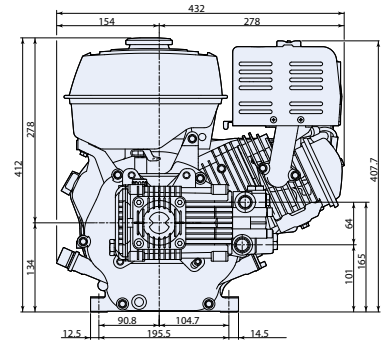
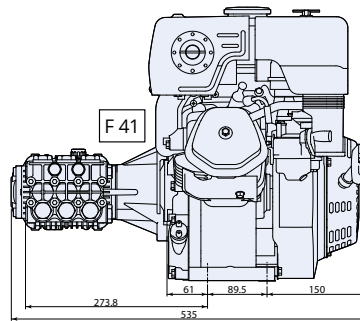

RKV 4 G20 Honda GX270

22885.27

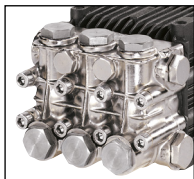
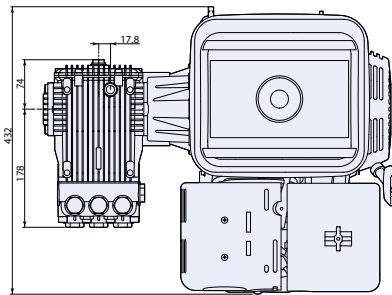

Model H

MOD	COD	MAX	MAX	RPM	NET		
Engine HP	l/min	gpm	bar	psi	N° giri/1' pompa	kg	
RKV Direct Drive							
RKV 4 G20 HONDA GX 270-QX Type	8,4 20880	15,1	4	140	2000	3400	35
● RKV 4 G30 H HONDA GX 270-QX Type	● 8,4 20882	15,1	4	205	3000	3400	35,5



● **testa nichelata**
nickel plated
brass head



● **bielle in bronzo**
connecting-rods
in bronze



testa in ottone
brass
head



bielle in alluminio
connecting-rods
in aluminum



motore a scoppio
gasoline
engine



- 
idropulitrici
pressure washers
- 
processi industriali
industrial processes
- 
autolavaggio
car wash
- 
agricoltura
agriculture
- 
cantieri ed edilizia
construction industry

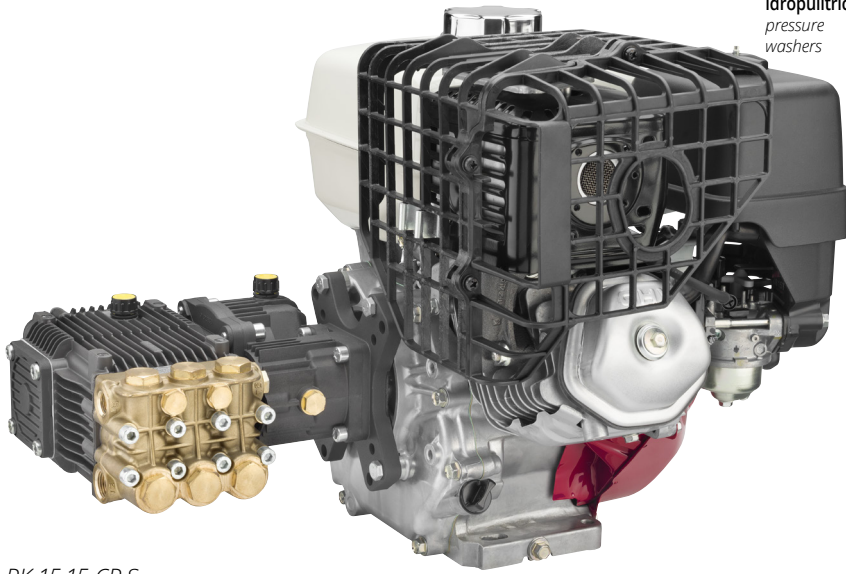

RK 15.15 CR S
(Honda engine)

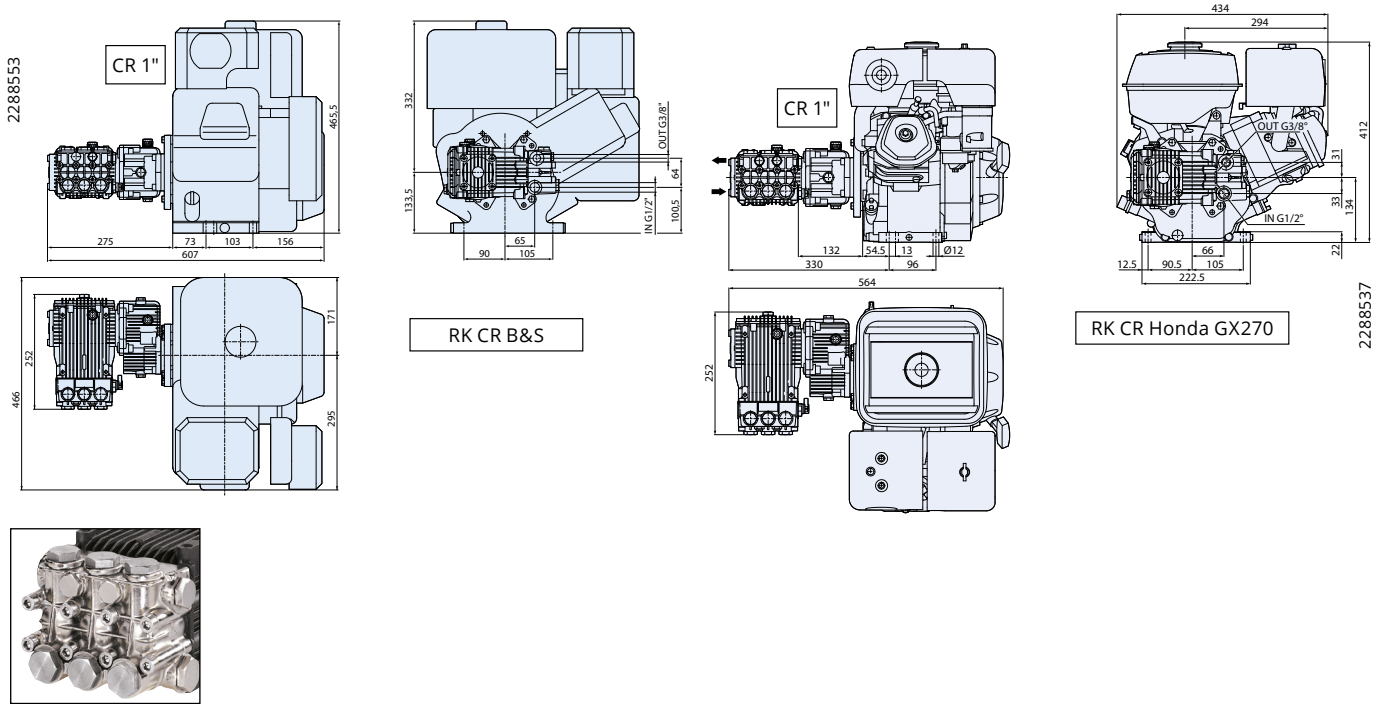

MOD	COD	MAX	MAX	RPM	NET		
	Engine HP	l/min	gpm	bar	psi	N° giri/1' pompa	kg
RK Gearbox Drive							
RK 15.15 CR HONDA GX 270-QX Type	8,4 20885	15	3,96	150	2200	1450	38
● RK 15.20 H CR B&S VANGUARD	13 20886	15	3,96	200	2900	1450	46
● RK 15.20 H CR HONDA GX 270-QX Type	8,4 20887	15	3,96	200	2900	1450	38

- 
testa nichelata
nickel plated brass head

bielle in alluminio
connecting-rods in aluminium
- 
testa in ottone
brass head

motore a scoppio
gasoline engine

402 SERIES

RG
RGA
RGX
RGXA



Corpo e coperchi in alluminio pressofuso.
Coperchio laterale con livello olio.
Coperchio posteriore con scarico olio.

Cuscinetti a rulli conici.
Bielle in lega zinco-alluminio pressofuso.
Testa in ottone stampato. Possibilità di testa in ottone nichelata.
Pistoni in ceramica.
Cuscinetti a rulli conici di alta qualità.

*Pump body and cover in pressure die-cast aluminium alloy.
Side cover incorporated with oil sight glass.
Back cover incorporated with oil drain outlet.
Tapered roller bearings.
Connecting rods in die-cast zinc-aluminium alloy.
Pump head in forged brass. Nickel-plated brass head available.
Ceramic pistons.
High quality tapered roller bearings.*

402 Series

POMPA ALBERO MASCHIO Solid shaft pump



lavaggio industriale
industrial cleaning



idropultrici
pressure washers



processi industriali
industrial processes



autolavaggio
car wash



agricoltura
agriculture



cantieri ed edilizia
construction industry



antincendio
fire fighting



Model H

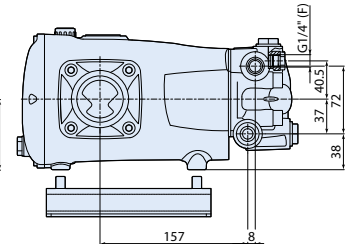
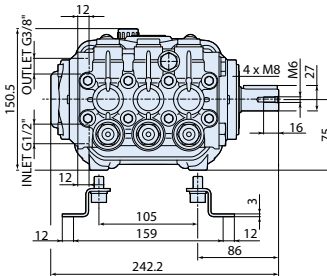
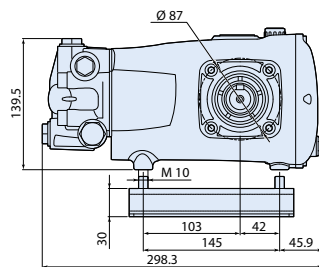



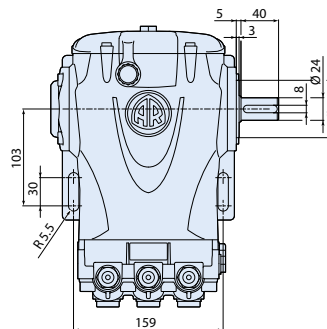

Piedi a richiesta.
Base on request.



4028500

N version

MOD	COD	 MAX	 MAX	 MAX	 MAX	hp	kW	N° giri/1'	 NET
		l/min	gpm	bar	psi				kg
RG 1450rpm Nversion Ø24mm									
RG 13.17 N	25399	13	3,43	170	2500	5,5	4	1450	14
RG 15.15 N	24962	15	3,96	150	2200	5,5	4	1450	14
● RG 15.20 H N	25400	15	3,96	200	2900	7,5	5,5	1450	14,5
● RG 15.25 H N	25401	15	3,96	250	3600	10	7,5	1450	14,5
RG 18.17 N	25402	18	4,75	170	2500	7,5	5,5	1450	14
● RG 18.20 H N	25403	18	4,75	200	2900	10	7,5	1450	14,5
RG 21.15 N	25404	21	5,55	150	2200	7,5	5,5	1450	14
● RG 21.20 H N	25405	21	5,55	200	2900	10	7,5	1450	14,5
● RG 21.25 H N	25406	21	5,55	250	3600	12,5	9,2	1450	14,5
RG 24.10 N	25943	24	6,34	100	1450	7,5	5,5	1450	14,5
RGA 1750rpm Nversion Ø24mm									
RGA 4G 22 N	25407	15,1	4	150	2200	5,5	4	1750	14
● RGA 4G 30 H N	25408	15,1	4	205	3000	7,5	5,5	1750	14,5
RGA 5.5G 22 N	25409	20,8	5,5	150	2200	7,5	5,5	1750	14,5
● RGA 5.5G 30 H N	25410	20,8	5,5	205	3000	10	7,5	1750	14,5



● **testa nichelata**
nickel plated brass head



testa in ottone
brass head



bielle in alluminio
connecting-rods in aluminium



RGX
RGXA

402 SERIES

Derivata dalla RG ma con testa di nuovo disegno per poter raggiungere pressioni più elevate grazie al posizionamento delle valvole di aspirazione sopra ai pistoni. Pompa a facile manutenzione grazie all'architettura della nuova testa.

Pump derived from the existing RG series pumps with a new-design head with the intake valves placed above the pistons to generate higher-than-normal pressures. The new head configuration simplifies pump maintenance.



NEW



402 Series

POMPA ALBERO MASCHIO Solid shaft pump



lavaggio industriale
industrial cleaning



idropultrici
pressure washers



processi industriali
industrial processes



agricoltura
agriculture



municipality



cantieri ed edilizia
construction industry





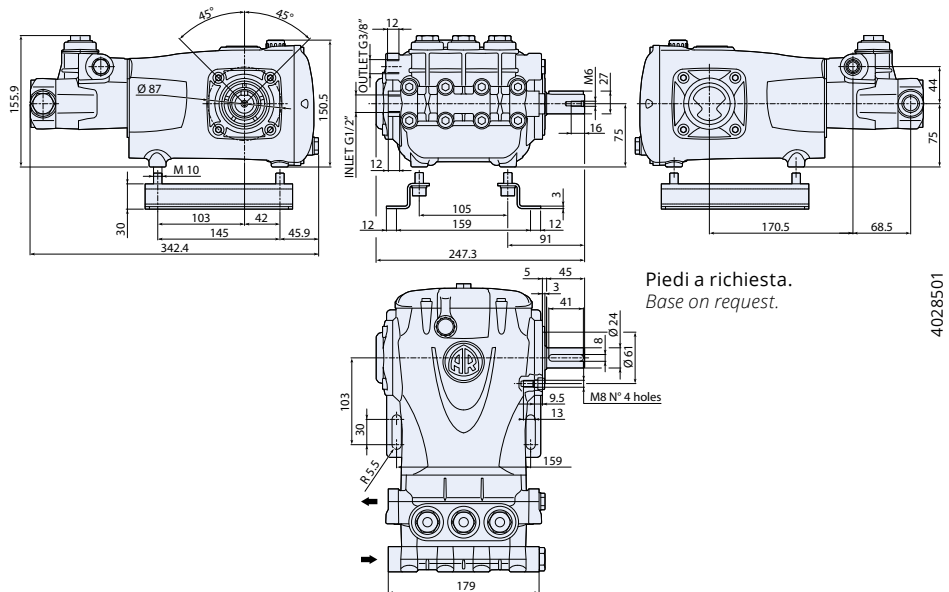

antincendio
fire fighting



4028501

N version

MOD	COD	 MAX	 MAX						
		l/min	gpm	bar	psi	hp	kW	N° giri/1'	kg
RGX 1450rpm Nversion Ø24mm									
RGX 15.50 N	25514	15	3,96	500	7250	20	15	1450	16
RGX 22.50 N	25638	22	5,8	500	7250	27	20	1450	16
RGXA 1750rpm Nversion Ø24mm									
RGXA 4G 70 N	25639	15,1	4	500	7250	20	15	1750	16

NEW



testa in ottone
brass head



bielle in alluminio
connecting-rods in aluminium

298 SERIES

RW
RWA
HRW



Corpo e coperchi in alluminio pressofuso.
Coperchio laterale con livello olio.
Coperchio posteriore con scarico olio.

Cuscinetti a rulli conici.

Bielle in lega zinco-alluminio pressofuso.
Testa in ottone stampato. Possibilità di testa in ottone nichelata.
Pistoni in ceramica.

Pump body and cover in pressure die-cast aluminium alloy.

Side cover incorporated with oil sight glass. Back cover incorporated with oil drain outlet.

Tapered roller bearings.

Connecting rods in die-cast zinc-aluminium alloy.

Pump head in forged brass. Nickel-plated brass head available.

Ceramic pistons.

298 Series

POMPA ALBERO MASCHIO Solid shaft pump



lavaggio industriale industrial cleaning	idropultrici pressure washers	processi industriali industrial processes	autolavaggio car wash	produzione manufacturing

agricoltura agriculture	municipality	misting	pulizia tubazioni sewer jetting	cantieri ed edilizia construction industry	antincendio fire fighting



Model H

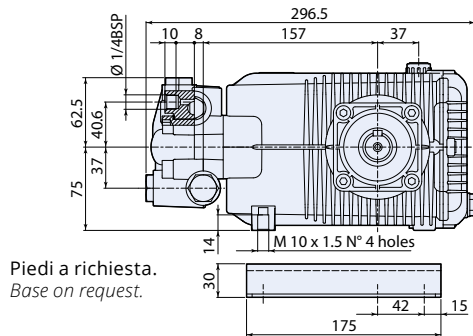

Piedi a richiesta.
Base on request.

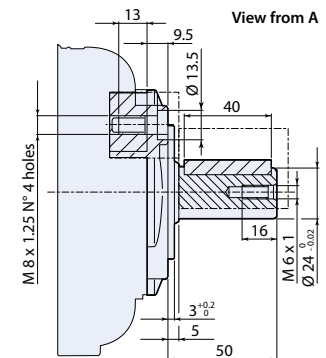
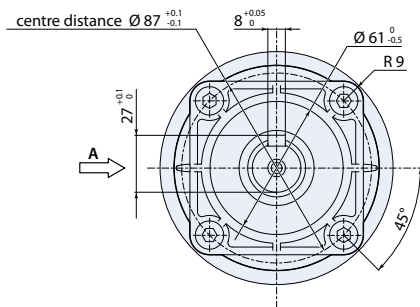
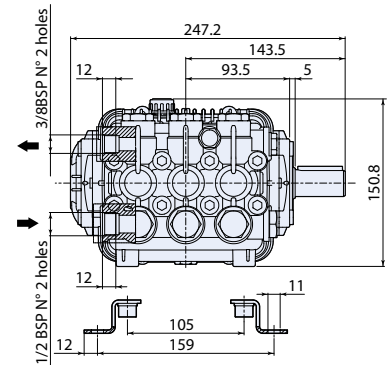

2988501

N version

MOD	COD								
		l/min	gpm	bar	psi	hp	kW	N° giri/1'	kg
RW 1450rpm Nversion Ø24mm									
RW 15.15 N	22584	15	3,96	150	2200	5,5	4	1450	14
● RW 15.20 H N	22585	15	3,96	200	2900	7,5	5,5	1450	14,5
RW 18.17 N	22586	18	4,75	170	2500	7,5	5,5	1450	14
● RW 18.20 H N	22587	18	4,75	200	2900	10	7,5	1450	14,5
● RW 21.15 H N	22588	21	5,55	150	2200	7,5	5,5	1450	14
● RW 21.20 H N	22589	21	5,55	200	2900	10	7,5	1450	14,5
RWA 1750rpm Nversion Ø24mm									
RWA 4G 22 N	22990	15,1	4	150	2200	5,5	4	1750	14
● RWA 4G 30 H N	22991	15,1	4	205	3000	7,5	5,5	1750	14,5
● RWA 5.5G 22 H N	22992	20,8	5,5	150	2200	7,5	5,5	1750	14,5
● RWA 5.5G 30 H N	22993	20,8	5,5	205	3000	10	7,5	1750	14,5

testa nichelata nickel plated brass head	testa in ottone brass head	bielle in alluminio connecting-rods in aluminium



298 Series

ELECTRIC MOTOR-PUMP UNITS

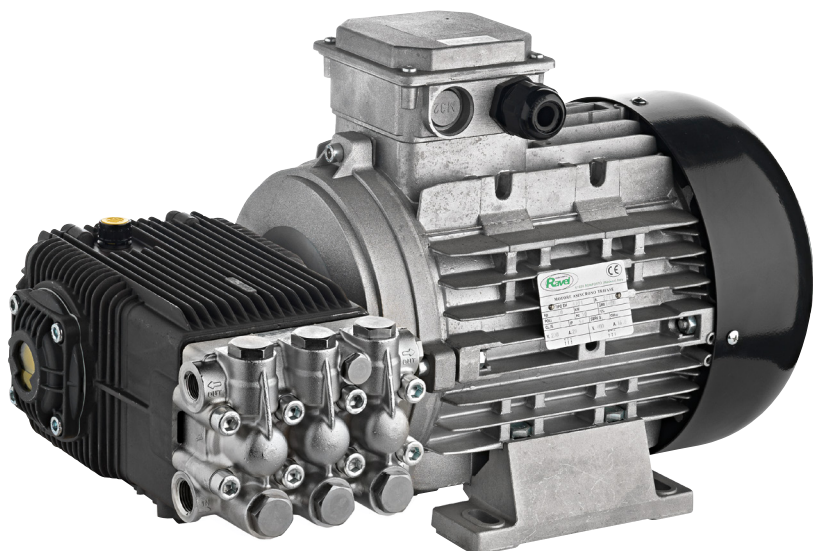

-  **lavaggio industriale**
industrial cleaning
-  **idropultrici**
pressure washers
-  **processi industriali**
industrial processes
-  **autolavaggio**
car wash
-  **produzione**
manufacturing
-  **agricoltura**
agriculture
-  **municipality**
-  **misting**
-  **pulizia tubazioni**
sewer jetting
-  **cantieri ed edilizia**
construction industry
-  **antincendio**
fire fighting

GR. 112 motor hollow shaft

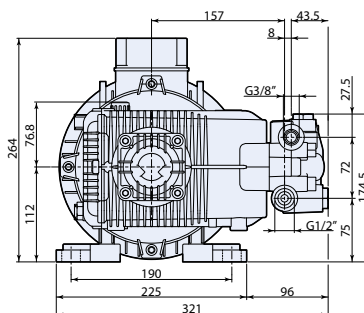
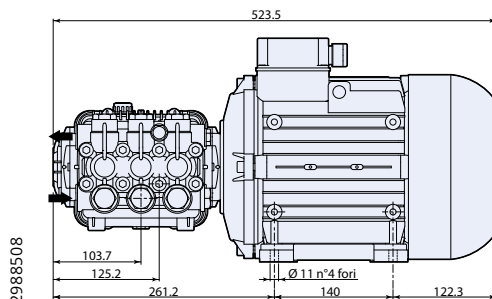

GR. 132 S motor hollow shaft

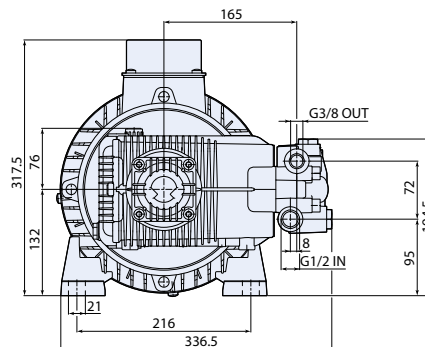
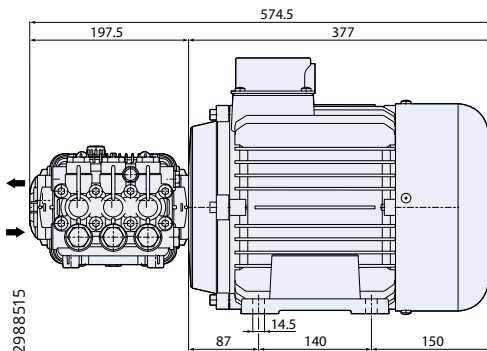

MOD	COD	 MAX	 MAX		KG NET						
	3 ~	l/min	gpm	bar	psi	hp	kW	N° giri/1'	V 3-50Hz	Gr.	kg
HRW 1450rpm											
HRW 15.15 ET	23974	15	3,96	150	2200	5,5	4	1450	230/400	112	30
 HRW 15.20 H ET	23975	15	3,96	200	2900	7,5	5,5	1450	230/400	112	40
 HRW 21.15 H ET	23976	21	5,50	150	2200	7,5	5,5	1450	230/400	112	40
 HRW 21.20 H ET	23977	21	5,50	200	2900	10	7,5	1450	230/400	132 S	50

-  **testa nichelata**
nickel plated brass head
-  **testa in ottone**
brass head
-  **bielle in alluminio**
connecting-rods in aluminium
-  **frequenza motore**
motor frequency





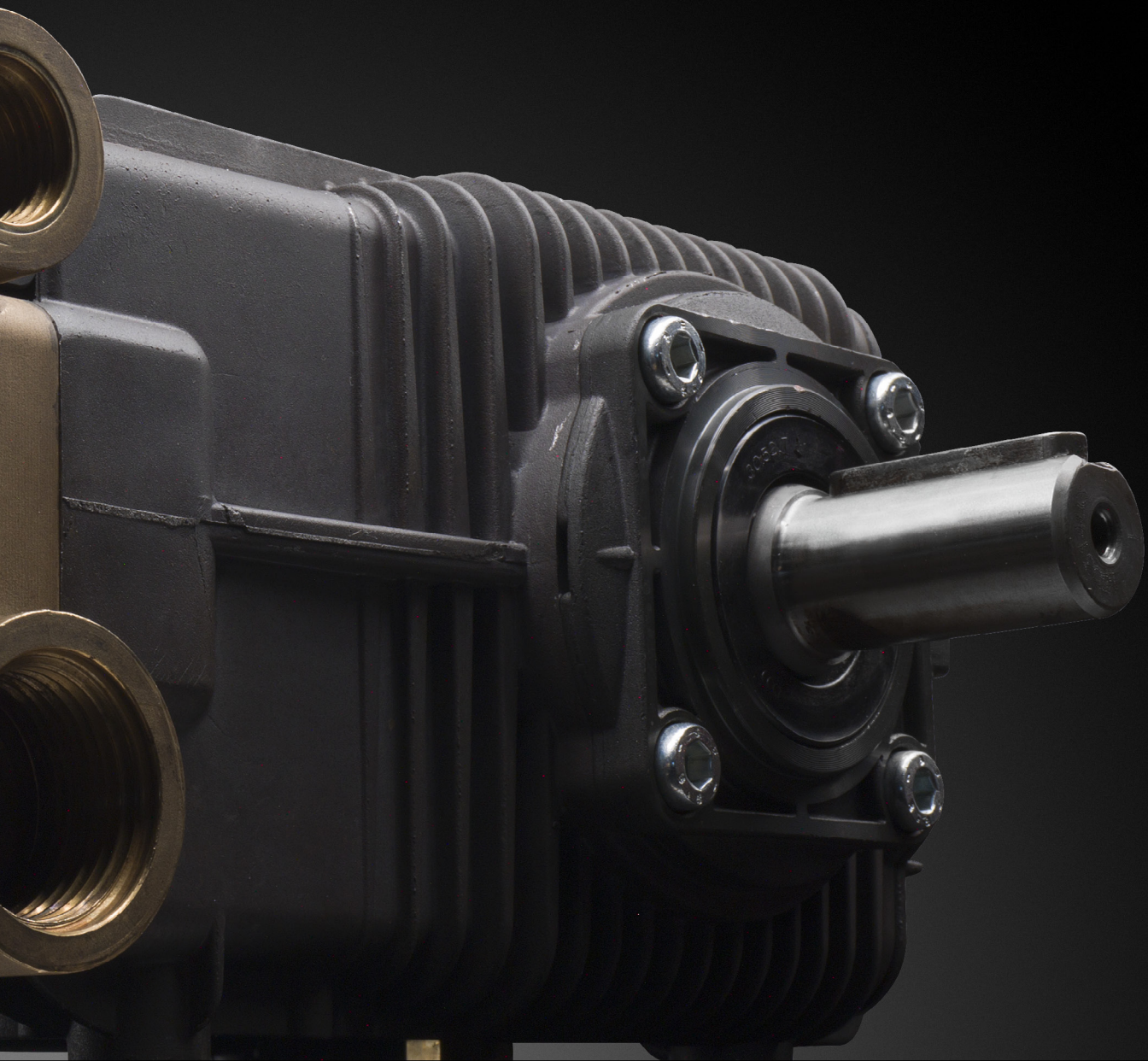

**194
SERIES**

194 SERIES

XWF
XW
XWL
XWT
XWA
XWLA
XWP

SXW
SXWA
SHP
SHPA
STP-I
STPA-I
CWX

WHW
WHWL
HXW
HXWL
HXWA
HSXW
HSHP
HYD-XW
HYD-XWL
XW+F38



Corpo e coperchi in alluminio pressofuso.

Coperchio laterale con livello olio.
Coperchio posteriore con scarico olio.

Bielle in lega zinco-alluminio pressofuso o in bronzo.

Testa in ottone stampato. Possibilità di testa in ottone nichelato.

Testa in AISI 420 per le versioni STP-I, STPA-I.

Pistoni in ceramica.

Pump body and cover in pressure die-cast aluminium alloy.

Side cover incorporated with oil sight glass. Back cover incorporated with oil drain outlet.

Connecting rods in die-cast zinc-aluminium alloy. Bronze connecting rods available.

Pump head in forged brass. Pump head in nickel-plated brass available.

Pump head in AISI 420 for STP-I and STPA-I models.

Ceramic pistons.

194 Series

POMPA ALBERO MASCHIO Solid shaft pump



lavaggio industriale
industrial cleaning



processi industriali
industrial processes



autolavaggio
car wash



produzione
manufacturing



agricoltura
agriculture



municipality



misting



pulizia tubazioni
sewer jetting



cantieri ed edilizia
construction industry



antincendio
fire fighting

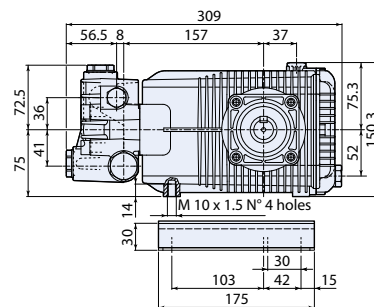

Piedi a richiesta.
Base on request.

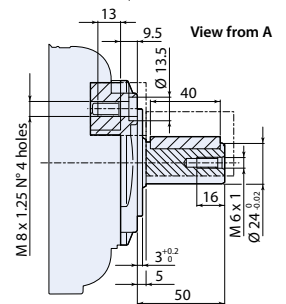
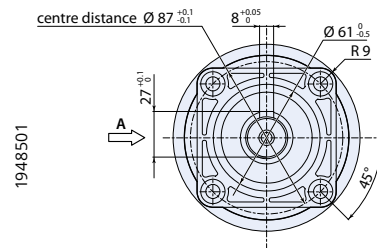
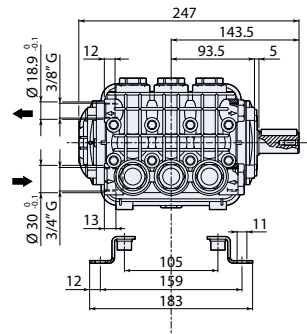

N version

MOD	COD	MAX		MAX				KG
		l/min	gpm	bar	psi	hp	kW	NET
XWF 1000rpm Nversion Ø24mm								
XWF 26.06 N	21049	26	6,87	60	900	4	3	16
XWF 26.09 N	21050	26	6,87	90	1300	5,5	4	16
XWF 26.12 N	21051	26	6,87	120	1740	7,5	5,5	16
XWF 26.15 N	21052	26	6,87	150	2200	10	7,5	16
XWF 26.20 N	21053	26	6,87	200	2900	13	9,6	16
XWF 30.10 N	21054	30	7,92	100	1450	7,5	5,5	16
XWF 30.18 N	21055	30	7,92	180	2600	15	11	16
XWF 30.20 N	22921	30	7,92	200	2900	15	11	16
XWF 36.17 N	21056	36	9,51	170	2500	15	11	16



testa in ottone
brass head



bielle in bronzo
connecting-rods in bronze



bielle in alluminio
connecting-rods in aluminium



194 Series

POMPA ALBERO MASCHIO Solid shaft pump



lavaggio industriale
industrial cleaning



idropultrici
pressure washers



processi industriali
industrial processes



autolavaggio
car wash



produzione
manufacturing



agricoltura
agriculture



municipality



misting



pulizia tubazioni
sewer jetting



cantieri ed edilizia
construction industry



antincendio
fire fighting

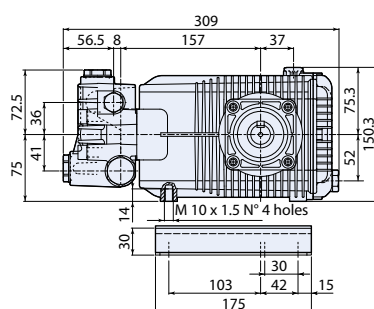

Piedi a richiesta.
Base on request.

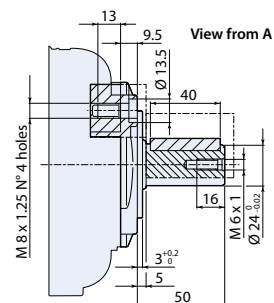
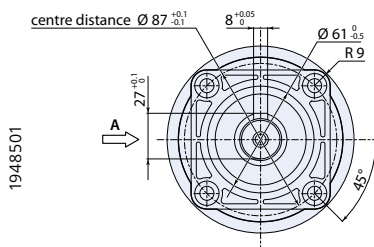
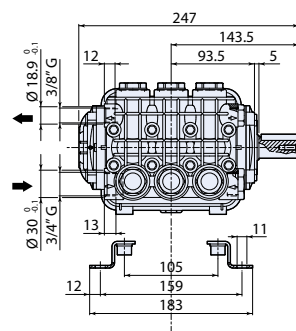

N version

MOD	COD	MAX	MAX	MAX	MAX	MAX	MAX	MAX	MAX
		l/min	gpm	bar	psi	hp	kW	N° giri/1'	kg
XW 1450rpm Nversion Ø24mm									
XW 15.15 N	20352	15	3,96	150	2200	5,5	4	1450	16
XW 15.20 N	20353	15	3,96	200	2900	7,5	5,5	1450	16
XW 15.30 N	20592	15	3,96	300	4350	12	8,7	1450	16
XW 21.20 N	20174	21	5,55	200	2900	10	7,5	1450	16
XW 21.25 N	20058	21	5,55	250	3600	12,5	9,2	1450	16
XW 21.28 N	21136	21	5,55	280	4060	15	11	1450	16
XW 26.12 N	20175	26	6,87	120	1740	7,5	5,5	1450	16
XW 26.15 N	20176	26	6,87	150	2200	10	7,5	1450	16
XW 26.20 N	20059	26	6,87	200	2900	12,5	9,2	1450	16
XW 26.23 N	20177	26	6,87	230	3400	15	11	1450	16
XW 30.10 N	20178	30	7,92	100	1450	7,5	5,5	1450	16
XW 30.15 N	20179	30	7,92	150	2200	10	7,5	1450	16
XW 30.20 N	20060	30	7,92	200	2900	15	10	1450	16
XW 30.25 N	21137	30	7,92	250	3600	19	14	1450	16

A richiesta testa nichelata · Nickel plated head available.



testa in ottone
brass head



bielle in alluminio
connecting-rods in aluminium

194 Series

POMPA ALBERO MASCHIO Solid shaft pump



for
XWL



for
XWT

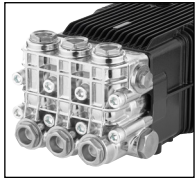

Model H

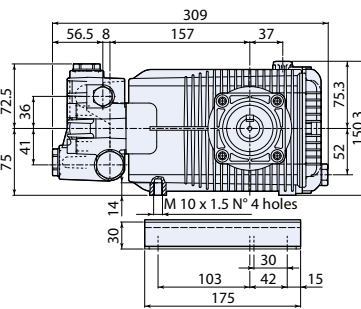

Piedi a richiesta.
Base on request.

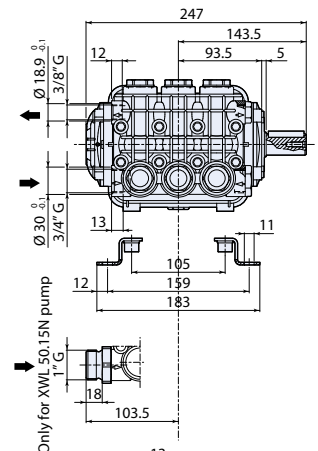

Only for XWL 50.15N pump
1" G

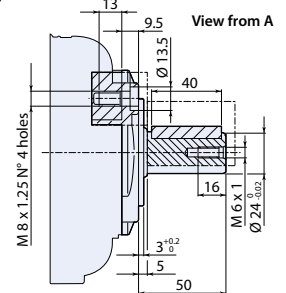
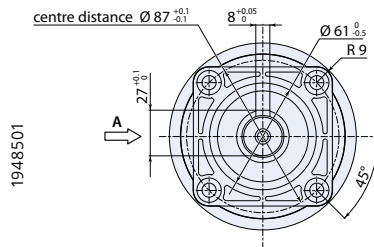

N version

MOD	COD	MAX	MAX						
		l/min	gpm	bar	psi	hp	kW	N° giri/1'	kg
XWL 1450rpm Nversion Ø24mm									
XWL 36.15 N	22175	36	9,51	150	2200	15	11	1450	16
XWL 41.20 N	22462	41	10,83	200	2900	20	15	1450	16
XWL 42.05 N	21057	42	11,09	50	725	5,5	4	1450	16
XWL 42.07 N	21058	42	11,09	70	1000	8	5,9	1450	16
XWL 42.10 N	21059	42	11,09	100	1450	11	8,2	1450	16
XWL 42.15 N	21060	42	11,09	150	2200	16	11,8	1450	16
XWL 50.15 N*	23709	50	13,20	150	2200	20	15	1450	16
● XWL 50.15 H N*	23816	50	13,20	150	2200	20	15	1450	16
XWT 550rpm Nversion Ø24mm									
XWT 21.18 N	21048	21	5,55	180	2600	10	7,5	550	16
XWT 21.20 N	22994	21	5,55	200	2900	15	11	550	16



● testa nichelata
nickel plated brass head

● bielle in bronzo
connecting-rods in bronze

● testa in ottone
brass head

● bielle in alluminio
connecting-rods in aluminium

* Minimo +0,1 bar (+1,5 psi) di pressione in entrata. • Min. +0,1 bar (+1,5 psi) inlet pressure.



194 Series

POMPA ALBERO MASCHIO Solid shaft pump



lavaggio industriale
industrial cleaning



processi industriali
industrial processes



autolavaggio
car wash



produzione
manufacturing



agricoltura
agriculture



municipality



misting



pulizia tubazioni
sewer jetting



cantieri ed edilizia
construction industry

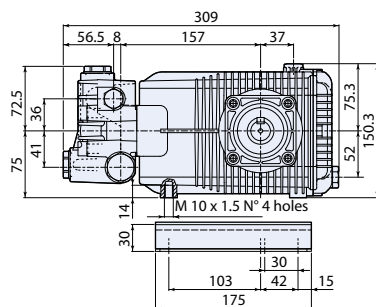

Piedi a richiesta.
Base on request.

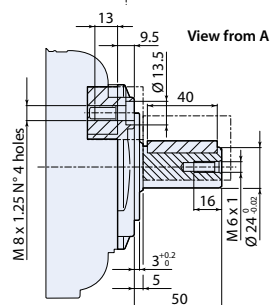
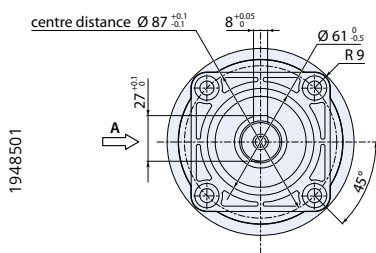
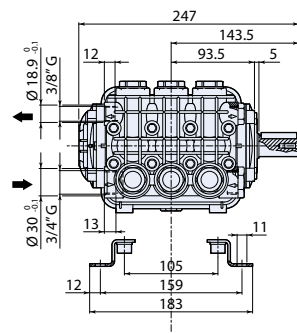

N version

MOD	COD	MAX	MAX		NET				
		l/min	gpm	bar	psi	hp	kW	N° giri/1'	kg

XWA 1750rpm Nversion Ø24mm

XWA 4 G20 N	20781	15,1	4	140	2000	5,5	4	1750	16
XWA 4 G30 N	20354	15,1	4	205	3000	7,5	5,5	1750	16
XWA 5.5 G22 N	20180	20,8	5,5	150	2200	7,5	5,5	1750	16
XWA 5.5 G30 N	20061	20,8	5,5	205	3000	10	7,5	1750	16
XWA 5.5 G40 N	21138	20,8	5,5	275	4000	14	10,5	1750	16
XWA 7 G22 N	20181	26,5	7	150	2200	10	7,5	1750	16
XWA 7 G32 N	20062	26,5	7	220	3200	14	10,5	1750	16
XWA 7 G35 N	21139	26,5	7	240	3500	15	11	1750	16
XWA 7 G40 N	21140	26,5	7	275	4000	17	12,5	1750	16
XWA 8 G19 N	20182	30,2	8	130	1900	10	7,5	1750	16
XWA 8 G29 N	20063	30,2	8	200	2900	15	11	1750	16
XWA 8 G35 N	21141	30,2	8	240	3500	18	13,4	1750	16
XWA 9 G16 N	20183	34	9	110	1600	10	7,5	1750	16
XWA 9 G24 N	20064	34	9	165	2400	15	11	1750	16
XWA 9 G30 N	21645	34	9	205	3000	18	13,4	1750	16

XWLA 1750rpm Nversion Ø24mm

XWLA 13 G15 N*	21198	49,2	13	100	1450	13	9,6	1750	16
----------------	--------------	------	----	-----	------	----	-----	------	----

* Minimo +0,1 bar (+1,5 psi) di pressione in entrata. • Min. +0,1 bar (+1,5 psi) inlet pressure.



testa in ottone
brass head



bielle in alluminio
connecting-rods in aluminium

194 Series

POMPA ALBERO MASCHIO Solid shaft pump



lavaggio industriale
industrial cleaning



processi industriali
industrial processes



autolavaggio car wash



produzione manufacturing



agricoltura agriculture



municipality



misting



pulizia tubazioni sewer jetting



cantieri ed edilizia construction industry

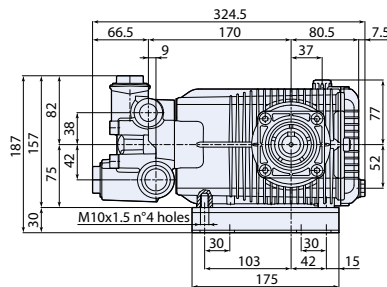

Piedi a richiesta.
Base on request.

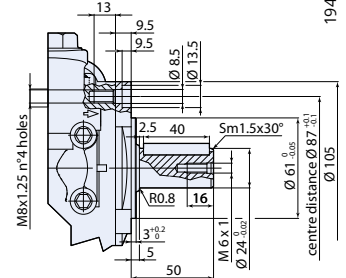
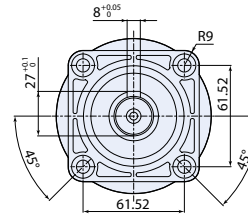
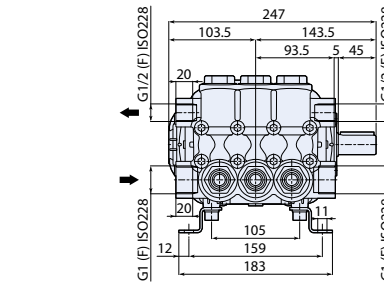
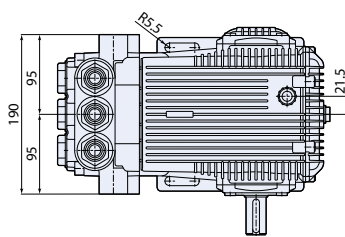





1948558

Parte meccanica della XW con pistoni maggiorati, nuovo design della testata con tenute e valvole che permettono di raggiungere portate maggiori.

Pump that maintains the drive of the XW. Larger-size pistons, new pump head design with seals and valves that enable to achieve higher flow rates (superior to 50 l/min).

N version

MOD	COD	 MAX	 MAX						
		l/min	gpm	bar	psi	hp	kW	N° giri/1'	kg
XWP 1450rpm Nversion Ø24mm									
XWP 50.15 N	26283	50	13,2	150	2200	20	15	1450	17,6
XWP 55.14 N	26284	55	14,5	140	2000	20	15	1450	17,6
XWP 60.13 N	26285	60	15,9	130	1900	20	15	1450	17,6
XWP 65.12 N	26286	65	17,2	120	1740	20	15	1450	17,6
XWP 70.12 N	26287	70	18,5	120	1740	20	15	1450	17,6
XWP 70.15 N	26919	70	18,5	150	2200	27	20	1450	17,6

A richiesta testa nichelata · Nickel plated head available.

NEW



testa in ottone
brass head



bielle in alluminio
connecting rods in aluminium



194 Series

POMPA ALBERO MASCHIO Solid shaft pump

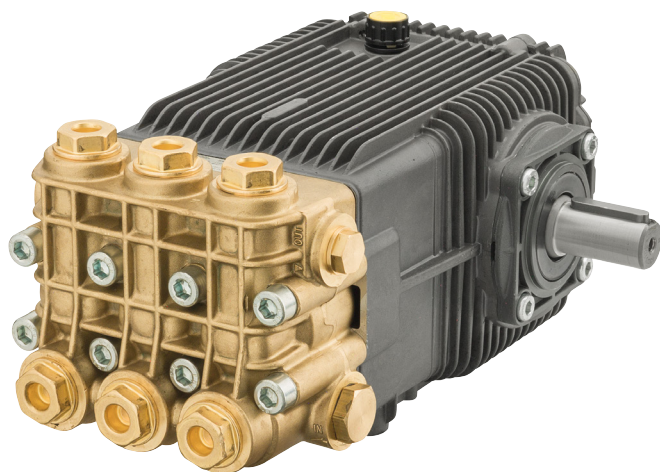

lavaggio industriale
industrial cleaning



idropultrici
pressure washers



processi industriali
industrial processes



agricoltura
agriculture



municipality



pulizia tubazioni
sewer jetting



cantieri ed edilizia
construction industry



antincendio
fire fighting

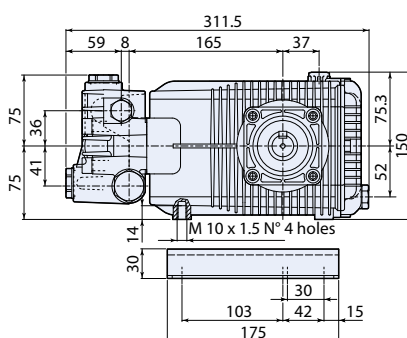

Piedi a richiesta.
Base on request.

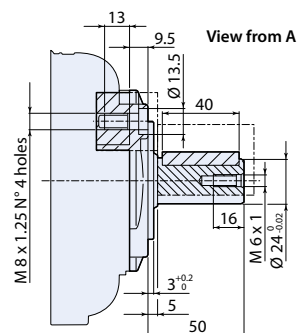
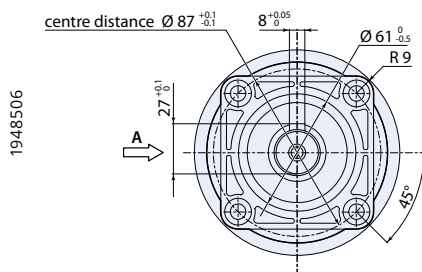
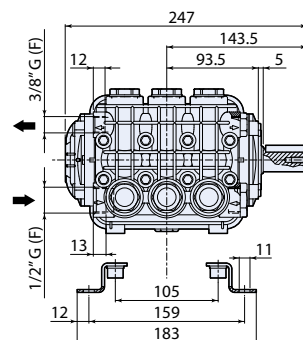

N version

MOD	COD	MAX	MAX	MAX	MAX	hp	kW	N° giri/1'	kg
		l/min	gpm	bar	psi				
SXW 1450rpm Nversion Ø24mm									
SXW 15.35 N	20807	15	3,96	350	5100	15	11	1450	16
SXW 17.35 N	23208	17	4,5	350	5100	17	12,7	1450	16
SXW 19.30 N	22899	19	5	300	4350	19	14,1	1450	16
SXW 21.28 N	20930	21	5,55	280	4060	20	15	1450	16
SXW 21.35 N	20808	21	5,55	350	5100	20	15	1450	16
SXWA 1750rpm Nversion Ø24mm									
SXWA 4 G 50 N	21024	15,1	4	345	5000	13	9,5	1750	16
SXWA 5.5G 50 N	21006	20,8	5,5	345	5000	18	13,4	1750	16
SXWA 7 G 50 N	21211	26,5	7	345	5000	22	16,2	1750	16



testa in ottone
brass head



bielle in alluminio
connecting-rods in aluminium

194 Series

POMPA ALBERO MASCHIO Solid shaft pump



lavaggio industriale
industrial cleaning



idropultrici
pressure washers



processi industriali
industrial processes



agricoltura
agriculture



pulizia tubazioni
sewer jetting



cantieri ed edilizia
construction industry



antincendio
fire fighting

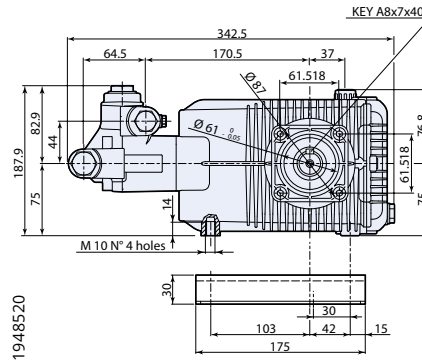

Piedi a richiesta.
Base on request.

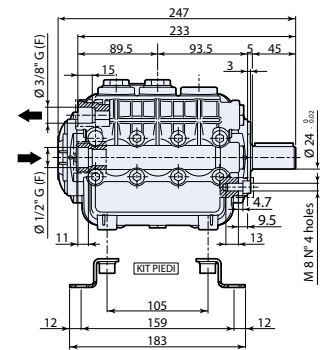

N version

MOD	COD	MAX		MAX				KG NET
		l/min	gpm	bar	psi	hp	kW	N° giri/1'
SHP 1450rpm Nversion Ø24mm								
SHP 10.50 N	22569	10	2,64	500	7250	14	10,4	1450
SHP 15.50 N	21825	15	3,96	500	7250	20	15	1450
SHP 20.50 N	25413	20	5,30	500	7250	25	18,5	1450
SHP 22.50 N	21826	22	5,80	500	7250	27	20	1450
SHPA 1750rpm Nversion Ø24mm								
SHPA 4 G 70 N	23022	15,1	4	500	7250	20	15	1750



testa in ottone
brass head



bielle in alluminio
connecting-rods in aluminium

STP-I
STPA-I

194 SERIES

STP-I Stainless Steel ad alta pressione
fino a 500 bar.

- Albero in acciaio ad alta resistenza e supportato da due **cuscinetti a rulli conici** di alta qualità e sovradimensionati.
- Bielle in speciale **lega zinco-alluminio antifrizione**.
- Corpo pompa e coperchi laterali in lega di **alluminio ad alta resistenza** per pressofusione e con trattamento di **anodizzazione**.
- Pistoni in **ceramica** integrale.
- Sistema di tenuta a **doppia guarnizione**.
- Testa in **acciaio inox** AISI 420.
- **Valvole di costruzione robusta** per reggere le alte pressioni di utilizzo.
- Coperchio posteriore con **scarico** e **livello olio**.
Livello olio laterale.

STP-I Stainless Steel pump up to 500 bar.

- *Shaft in high-strength steel supported by two high-quality, oversized tapered roller bearings.*
- *Connecting rods in a special low-friction zinc-aluminium alloy.*
- *Pump head in stainless steel AISI 420.*
- *Body and side covers in anodised die-cast high-strength aluminium alloy.*
- *Ceramic pistons.*
- *Double gasket sealing system.*
- *Valves are of rugged construction to withstand the high operating pressures.*
- *Back cover incorporated with oil sight glass and oil drain outlet. Lateral oil sight glass.*

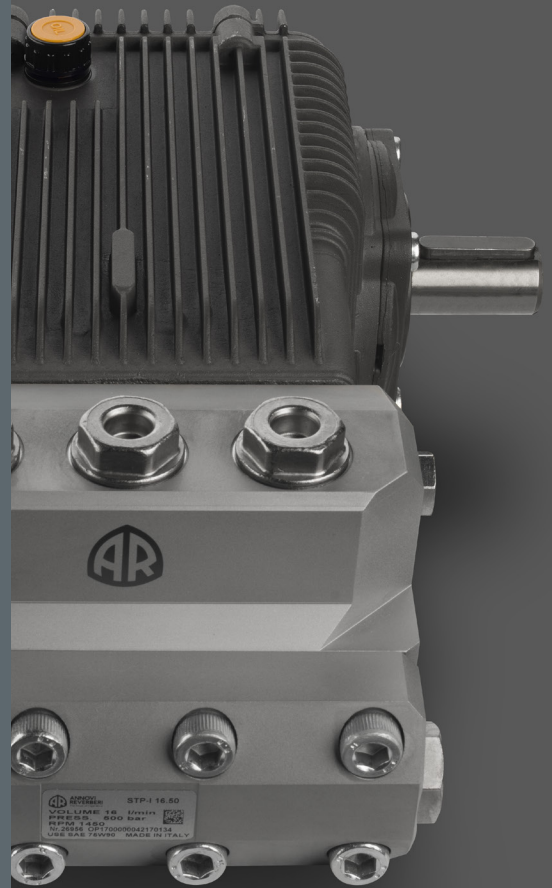

NEW

**AISI
420**



194 Series

POMPA ALBERO MASCHIO Solid shaft pump

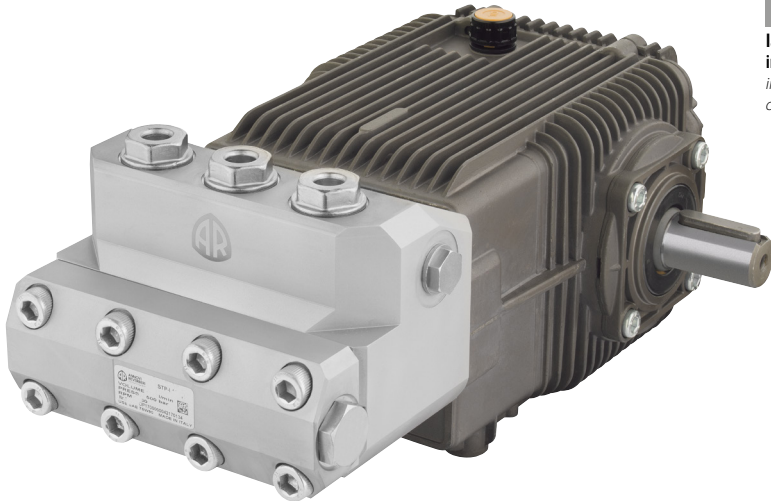

lavaggio industriale
industrial cleaning



idropultrici
pressure washers



processi industriali
industrial processes



municipality



pulizia tubazioni
sewer jetting



cantieri ed edilizia
construction industry



settore navale
marine industry

Piedi a richiesta.
Base on request.

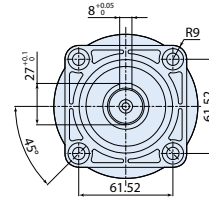
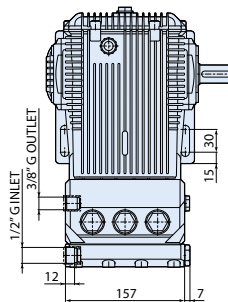
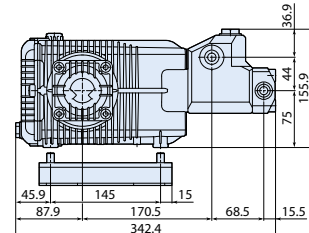
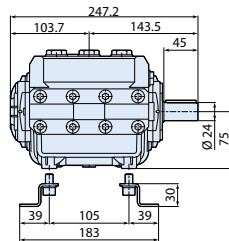

Flangiatura pompa
Pump flange

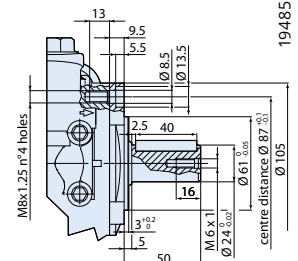

1948561

N version

MOD	COD	MAX		MAX				KG NET
		l/min	gpm	bar	psi	hp	kW	N° giri/1'
STP-I 1450rpm Nversion Ø24mm								
STP-I 10.50 N	27170	10	2,64	500	7250	14	10,4	1450
STP-I 15.50 N	26597	15	3,96	500	7250	20	15	1450
STP-I 20.50 N	27171	20	5,30	500	7250	25	18,5	1450
STP-I 22.50 N	27172	22	5,80	500	7250	27	20	1450
STPA-I 1750rpm Nversion Ø24mm								
STPA-I 4 G 70 N	27173	15,1	4	500	7250	20	15	1750
STPA-I 5.5 G 70 N	27167	20,8	5,5	500	7250	25,5	19	1750



testa in inox
inox head



bielle in alluminio
connecting-rods in aluminium



194 Series

POMPA ALBERO MASCHIO Solid shaft pump



autolavaggio
car wash

CAR WASH

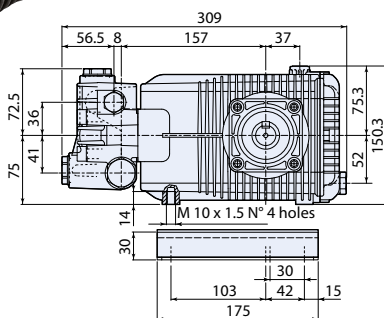
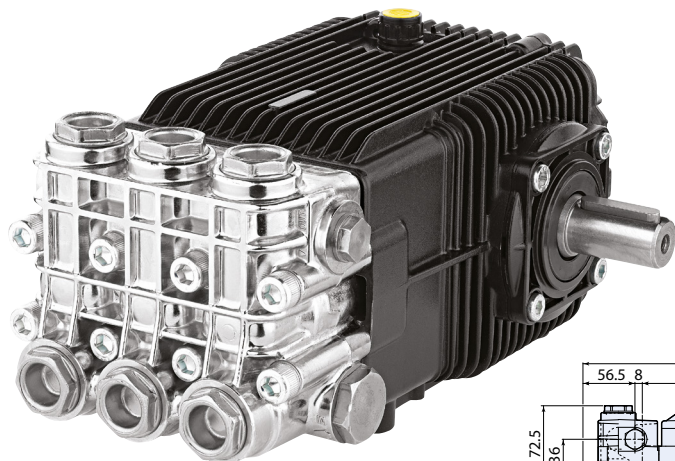

Piedi a richiesta.
Base on request.

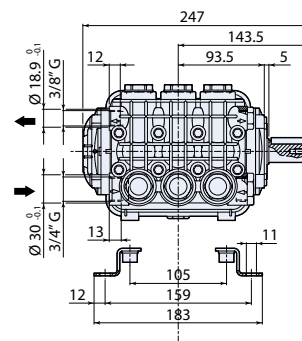

1948501

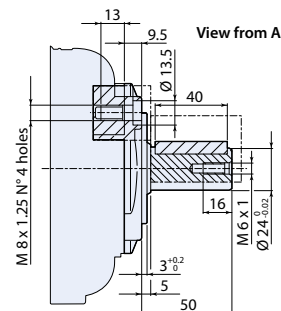
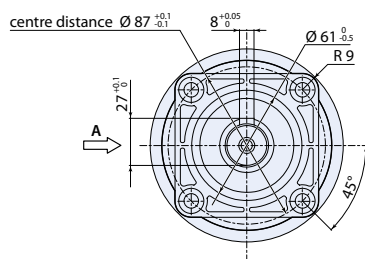

N version

MOD	COD	MAX	MAX						
		l/min	gpm	bar	psi	hp	kW	N° giri/1'	kg
CWX 950rpm Nversion Ø24mm									
CWX 15.17 N	20472	15	3,96	170	2500	7,5	5,2	950	16
CWX 1200rpm Nversion Ø24mm									
CWX 18.10 N	20473	18	4,75	100	1450	5,5	3,6	1200	16
CWX 1750rpm Nversion Ø24mm									
CWX 15.17 N	20474	15	3,96	170	2500	7,5	5,2	1750	16



testa
nichelata
nickel plated
brass head



bielle in
alluminio
connecting-rods
in aluminium

194 Series

POMPA ALBERO MASCHIO Solid shaft pump



autolavaggio municipality
car wash

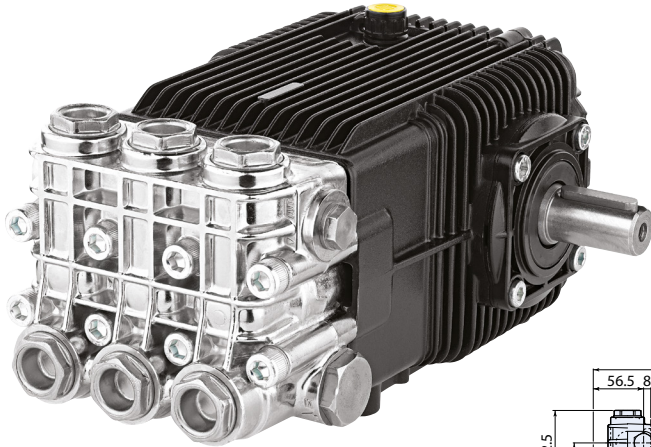

HOT WATER 85°C

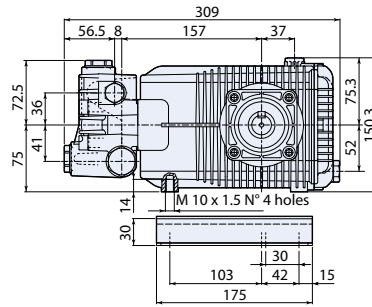

Piedi a richiesta.
Base on request.

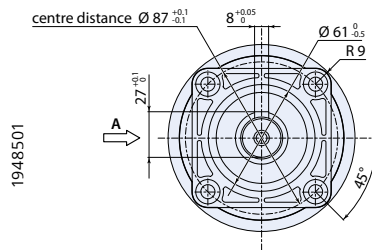

1948501

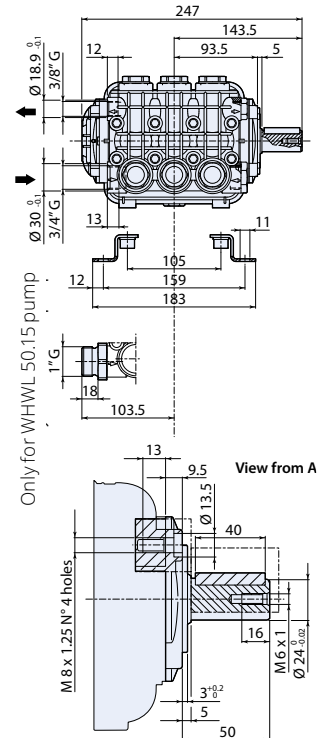

Only for WHWL 50:15 pump

N version

MOD	COD	MAX	MAX						
		l/min	gpm	bar	psi	hp	kW	N° giri/1'	kg
WHW 1450rpm Nversion Ø24mm									
WHW 15.20 N	22986	15	3,96	200	2900	7,5	5,5	1450	16
WHW 21.15 N	22987	21	5,55	150	2200	7,5	5,5	1450	16
WHW 26.15 N	22988	26	6,87	150	2200	10	7,5	1450	16
WHW 32.20 N	22989	32	8,45	200	2900	15	11	1450	16
WHWL 1450rpm Nversion Ø24mm									
WHWL 38.15 N	23966	38	9,81	150	2200	15	11	1450	16,5
WHWL 42.15 N	23967	42	11,09	150	2200	16	11,8	1450	16,5
WHWL 50.15 N	23968	50	13,20	150	2200	20	15	1450	16,5



testa
nichelata
nickel plated
brass head



guarnizioni
in PTFE
PTFE gasket
sealing



bielle in
alluminio
connecting-rods
in aluminium



194 Series

ELECTRIC MOTOR-PUMP UNITS



lavaggio industriale
industrial cleaning



idropultrici
pressure washers



processi industriali
industrial processes



autolavaggio
car wash



produzione
manufacturing



agricoltura
agriculture



municipality



misting



pulizia tubazioni
sewer jetting



cantieri ed edilizia
construction industry

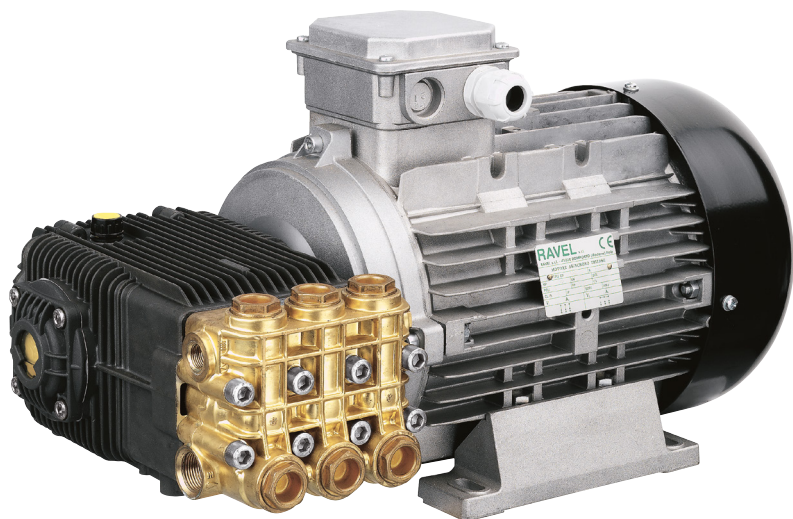

GR. 100 motor hollow shaft

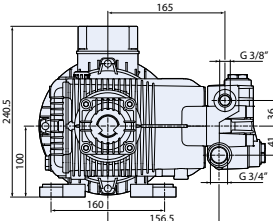
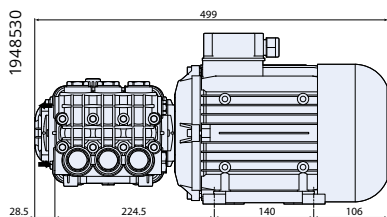

GR. 112 motor hollow shaft

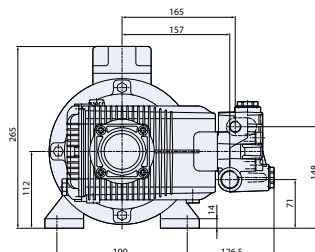
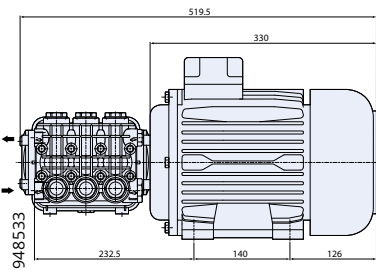

GR. 132 S motor hollow shaft

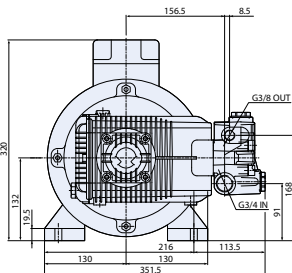
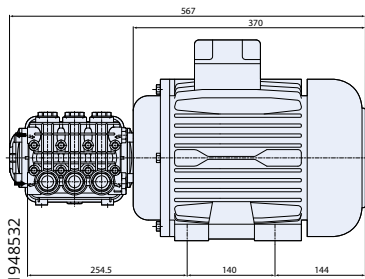

GR. 132 L motor hollow shaft

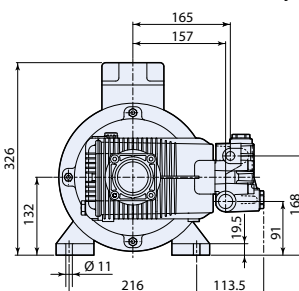
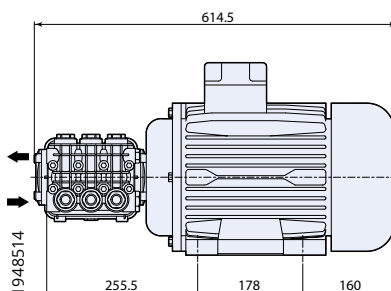

COD	3 ~	l/min	gpm	bar	psi	hp	kW	N° giri/1'	V 3-50Hz	Gr.	kg
HXW 1450 rpm											
HXW 15.15 ET	20871	15	3,96	150	2200	5,5	4	1450	230/400	100	33
HXW 15.20 ET	20872	15	3,96	200	2900	7,5	5,5	1450	230/400	112	39
HXW 21.20 ET	20224	21	5,55	200	2900	10	7,5	1450	230/400	132 S	63
HXW 26.15 ET	20225	26	6,87	150	2200	10	7,5	1450	230/400	132 S	63
HXW 30.10 ET	20227	30	7,92	100	1450	7,5	5,5	1450	230/400	112	39
HXW 30.15 ET	20228	30	7,92	150	2200	10	7,5	1450	230/400	132 S	63
HXW 30.20 ET	20229	30	7,92	200	2900	15	11	1450	230/400	132 L	70



testa in ottone
brass head



bielle in alluminio
connecting-rods in aluminium



frequenza motore
motor frequency

194 Series

ELECTRIC MOTOR-PUMP UNITS

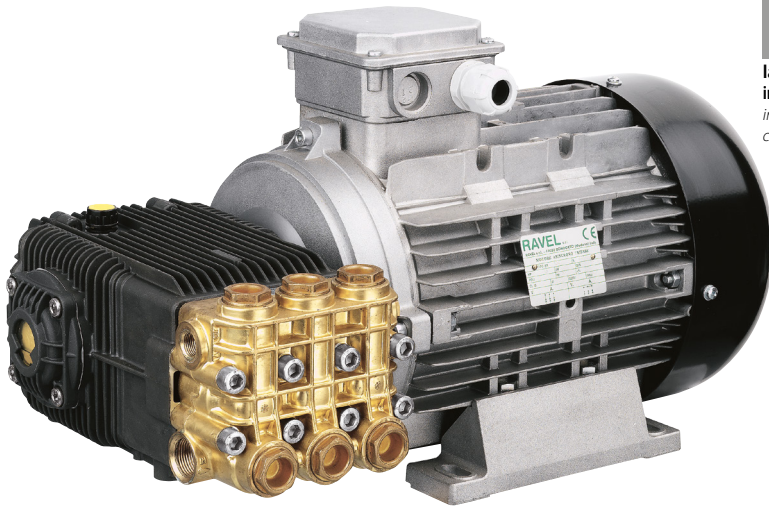

- 
lavaggio industriale
industrial cleaning
- 
idropultrici
pressure washers
- 
processi industriali
industrial processes
- 
autolavaggio
car wash
- 
produzione
manufacturing
- 
agricoltura
agriculture
- 
municipality
- 
misting
- 
pulizia tubazioni
sewer jetting
- 
cantieri ed edilizia
construction industry

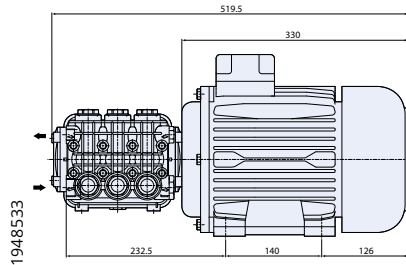

GR. 112 motor hollow shaft

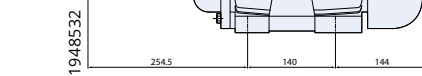
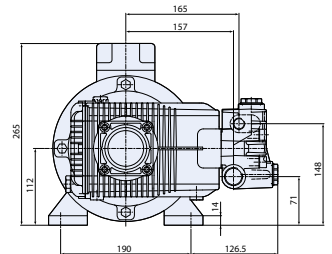

GR. 132 S motor hollow shaft

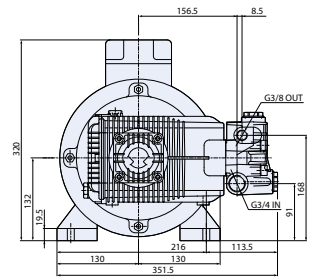

COD	3 ~	MAX		MAX		N° giri/1'				Gr.	kg
		l/min	gpm	bar	psi	hp	kW	V			
HXWL 1450 rpm											
HXWL 42.07 ET	21183	42	11,09	70	1000	7,5	5,5	1450	230/400 ^c	112	39
HXWL 42.10 ET	21184	42	11,09	100	1450	10	7,5	1450	230/400 ^c	132 S	63
HXWA 1750 rpm											
HXWA 4 G20 ET	20782	15,1	4	140	2000	5,5	4	1750	230/400 ^d	112	33
HXWA 4 G30 ET	20783	15,1	4	205	3000	7,5	5,5	1750	230/400 ^d	112	39



testa in ottone
brass head



bielle in alluminio
connecting-rods in aluminium



3~50Hz
frequenza motore
motor frequency

c) 3~ 50 Hz • d) 3~ 60 Hz



194 Series

ELECTRIC MOTOR-PUMP UNITS



lavaggio industriale
industrial cleaning



idropultrici
pressure washers



processi industriali
industrial processes



agricoltura
agriculture



municipality



pulizia tubazioni
sewer jetting



cantieri ed edilizia
construction industry

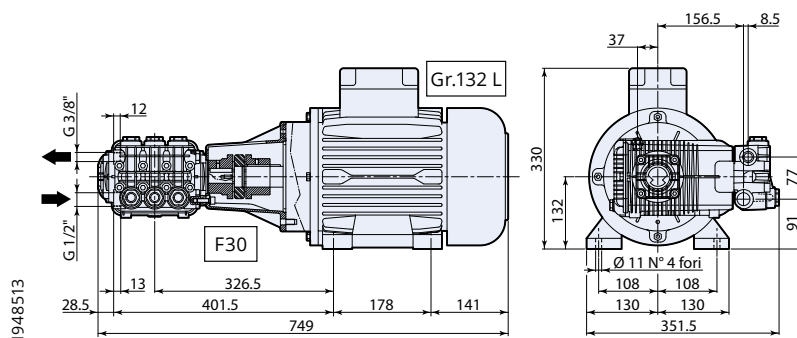

Flangiatura con giunto elastico.
Bell housing + flexible coupling.

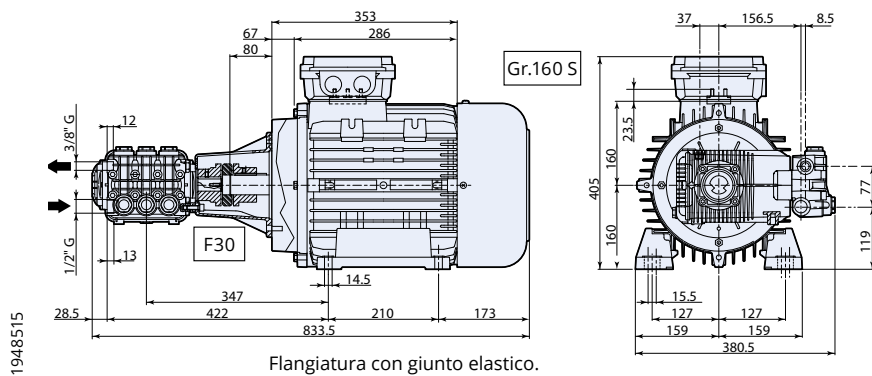

Flangiatura con giunto elastico.
Bell housing + flexible coupling.

COD	3 ~		MAX		MAX		N° giri/1'		V 3-50Hz	Gr.	KG NET
	l/min	gpm	bar	psi	hp	kW					
HSXW 1450 rpm											
HSXW 15.35 ET	21066	15,1	4	350	5100	15	11	1450	230/400	132 L	75
HSXW 21.35 ET	22995	21	5,55	350	5100	20	15	1450	400/690	160 S	115



testa in ottone
brass head



bielle in alluminio
connecting-rods in aluminium



frequenza motore
motor frequency

194 Series

ELECTRIC MOTOR-PUMP UNITS

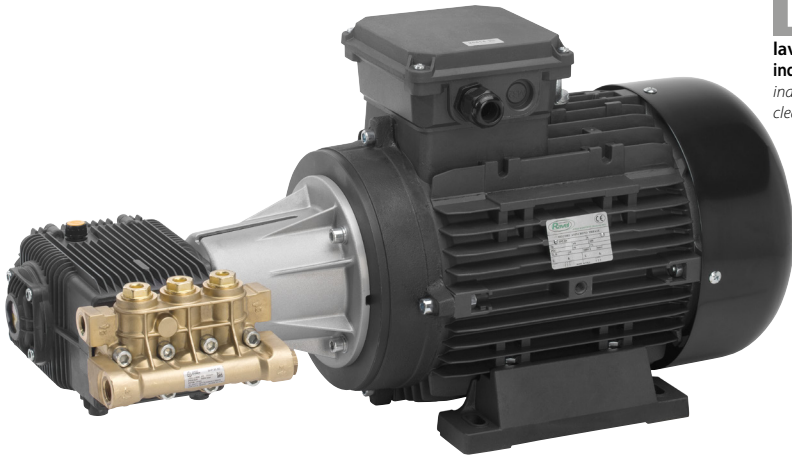

lavaggio industriale
industrial cleaning



idropultrici
pressure washers



processi industriali
industrial processes



agricoltura
agriculture



pulizia tubazioni
sewer jetting



cantieri ed edilizia
construction industry

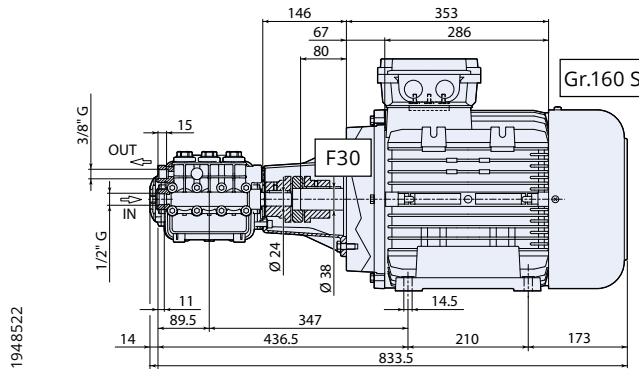

Flangiatura con giunto elastico.
Bell housing + flexible coupling.

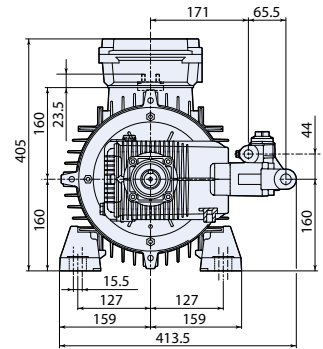

COD	MAX		MAX						NET		
	3 ~	l/min	gpm	bar	psi	hp	kW	N° giri/1'	V 3-50Hz	Gr.	kg
HSHP 1450rpm											
HSHP 15.50 ET	22082	15	3,96	500	7250	20	15	1450	400/690	160 S	115
HSHP 20.50 ET	25414	20	5,30	500	7250	25	18,5	1450	400/690	160 S	115



testa in ottone
brass head



bielle in alluminio
connecting-rods in aluminium



3~50Hz
frequenza motore
motor frequency



194 Series

GASOLINE MOTOR-PUMP UNITS



idropultrici
pressure
washers



processi
industriali
industrial
processes



autolavaggio
car wash



agricoltura
agriculture



municipality



cantieri ed
edilizia
construction
industry

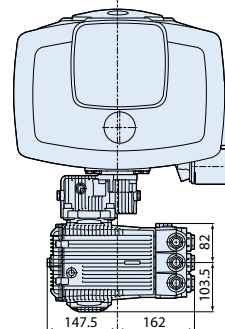
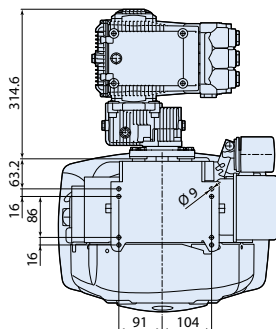
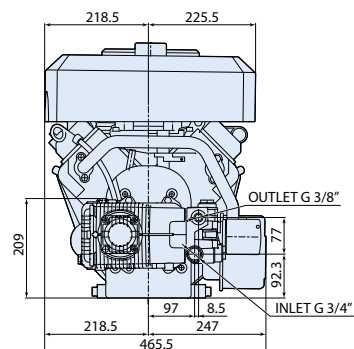
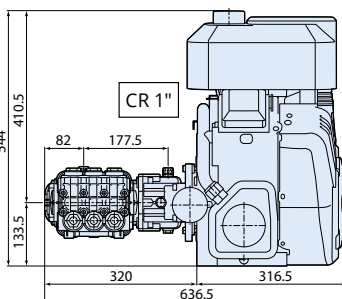
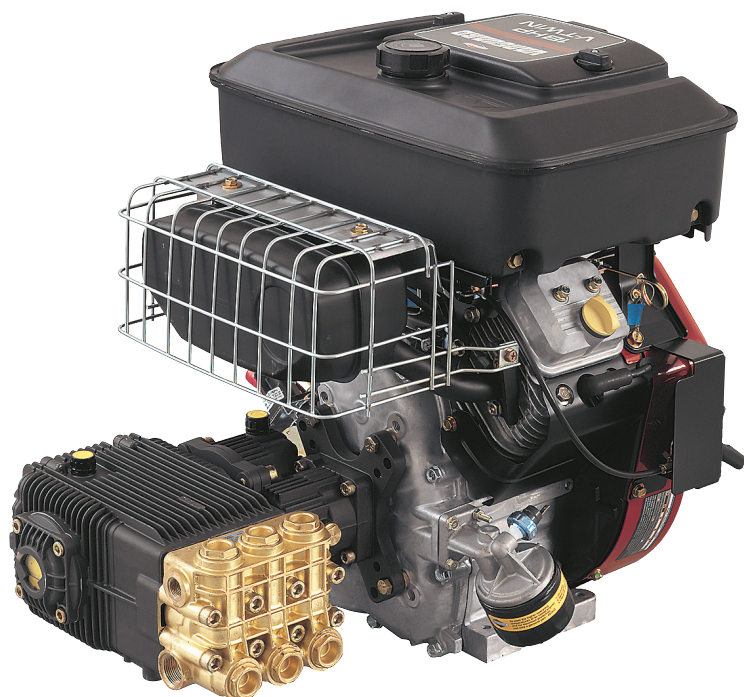

1948541

MOD	COD	MAX	MAX	RPM	NET		
	Engine HP	l/min	gpm	bar	psi	N° giri/1' pompa	kg
XW Gearbox Drive							
XW 30.15 CR B&S VANGUARD	18 20241	30	7,92	150	2200	1450	53



testa in
ottone
brass
head



bielle in
alluminio
connecting-rods
in aluminium



motore a
scoppio
gasoline
engine

194 Series

HYDRAULIC DRIVE

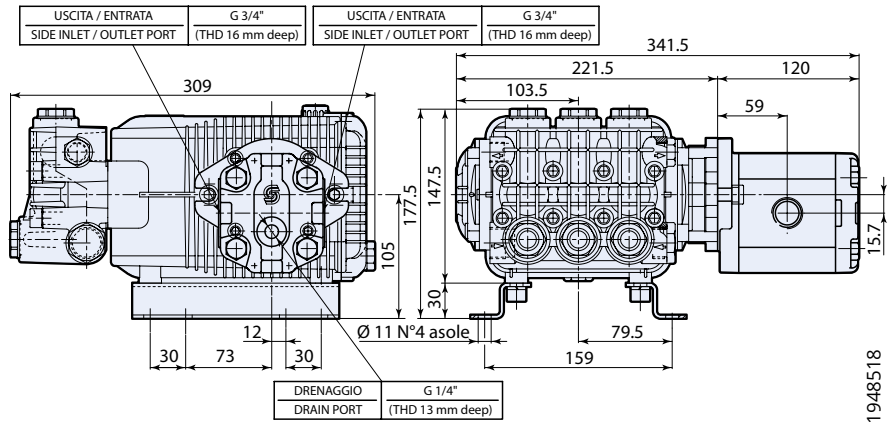
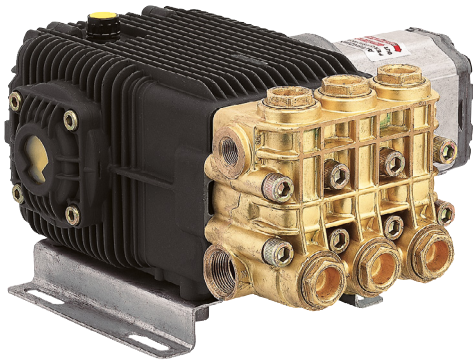

1948518



HYD - XW • HYD - XWL

MOD	COD	POMPA A PISTONI • HP PISTON PUMP						MOTORE IDRAULICO • HYDRAULIC MOTOR						KG NET
		SAUER DANFOSS (*)		SAUER DANFOSS (*)		SAUER DANFOSS (*)		SAUER DANFOSS (*)		SAUER DANFOSS (*)				
		l/min	gpm	bar	psi	N° giri/1'	hp	Type	Cod	cm ³	bar	l/min	N° giri/1'	kg
HYD-XW														
HYD-XW 30.10	21606	30	7,92	100	1450	1450	7,5	SNM2NN/022 BN06GAM1F5F5N	4770	22,8	125	36	1450	16,2
HYD-XW 30.15	22694	30	7,92	150	2200	1450	12	SNM2NN/022 BN06GAM1F5F5N	4770	22,8	180	36	1450	16,2
HYD-XWL														
HYD-XWL 50.09	25049	50	13,2	90	1300	1450	12	SNM2NN/022 BN06GAM1F5F5N	4770	22,8	180	36	1450	16,2

*) A richiesta disponibili motori idraulici Casappa - Marzocchi
 *) On request available Hydraulic Motor type: Casappa - Marzocchi



HYDRAULIC DRIVE

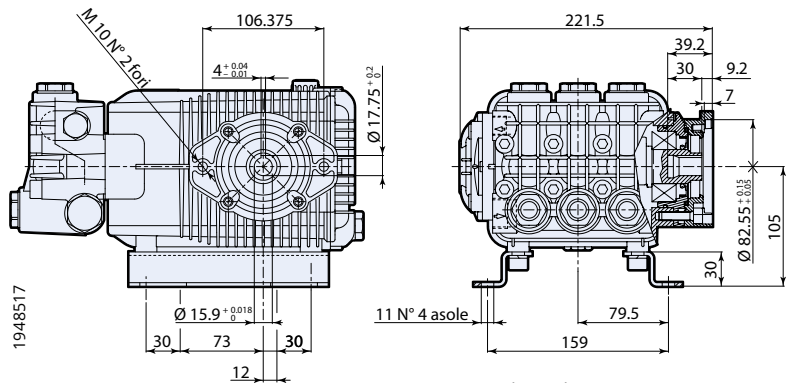

Piedi a richiesta.
Base on request.



XW + F38

MOD	COD	SAUER DANFOSS (*)		SAUER DANFOSS (*)		SAUER DANFOSS (*)		SAUER DANFOSS (*)		KG NET
		l/min	gpm	bar	psi	hp	kW	N° giri/1'	kg	
XW 1450rpm + F38										
XW 30.10 + F38	21601	30	7.92	100	1450	7,5	5,5	1450	3,4	
XW 30.15 + F38	22318	30	7.92	150	2200	10	7,5	1450	3,4	



366 SERIES

RTX
RTX-I
HRTX
HYD-RTX



Corpo e coperchi in alluminio pressofuso.

Coperchio posteriore con scarico olio.
Livello olio nel coperchio laterale.

Cuscinetti a rulli conici.

Bielle in lega zinco-alluminio o in bronzo.

Testa in ottone stampato e nichelata.
Testa in AISI 420 per la versione RTX-I.

Pistoni in ceramica.

Pump body and cover in pressure die-cast aluminium alloy.

Back cover incorporated with oil drain outlet.

Cover lateral oil sight glass.
Tapered roller bearings.

Connecting rods in pressure die-cast zinc-aluminium alloy. Bronze connecting rods available.

Nickel-plated forged brass pump head.
Pump head in AISI 420 for RTX-I model.

Ceramic pistons.

366 Series

POMPA ALBERO MASCHIO Solid shaft pump



- 
lavaggio industriale
industrial cleaning
- 
processi industriali
industrial processes
- 
autolavaggio
car wash
- 
produzione
manufacturing
- 
agricoltura
agriculture
- 
municipality
- 
misting
- 
pulizia tubazioni
sewer jetting
- 
antincendio
fire fighting

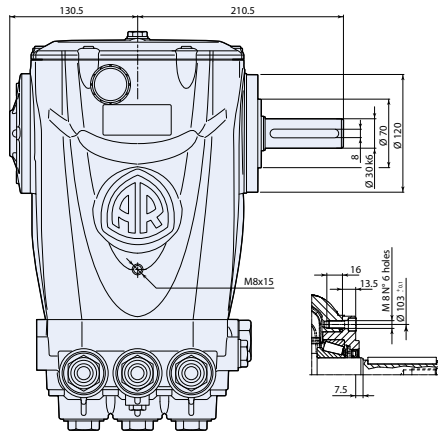
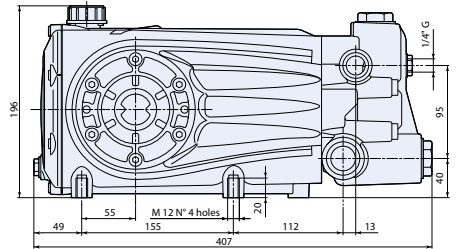
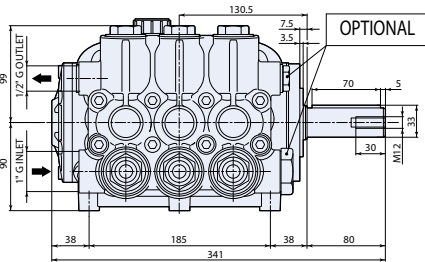

3668500

N version

MOD	COD	MAX		MAX				KG	NET
		l/min	gpm	bar	psi	hp	kW	N° giri/1'	kg
RTX 1450 rpm Nversion Ø30mm									
RTX 30.300 N	24448	30	7,92	300	4350	24	18	1450	32,5
RTX 50.300 N	26226	50	13,2	300	4350	40	30	1450	32,5
RTX 60.300 N	26068	60	15,8	300	4350	47	35	1450	32,5
RTX 70.150 N	24446	70	18,5	150	2200	30	22	1450	32,5
RTX 70.200 N DX	28258	70	18,5	200	2900	37	28	1450	32,5
RTX 70.200 N SX	28261	70	18,5	200	2900	37	28	1450	32,5
RTX 85.150 N DX	28259	85	22,5	150	2200	34	26	1450	32,5
RTX 100.120 N DX	27717	100	26,4	120	1740	30	22	1450	32,5



testa nichelata
nickel plated brass head



bielle in alluminio
connecting-rods in aluminium



366 Series

POMPA ALBERO MASCHIO Solid shaft pump



lavaggio industriale
industrial cleaning



processi industriali
industrial processes



autolavaggio
car wash



produzione
manufacturing



agricoltura
agriculture



municipality



misting



pulizia tubazioni
sewer jetting

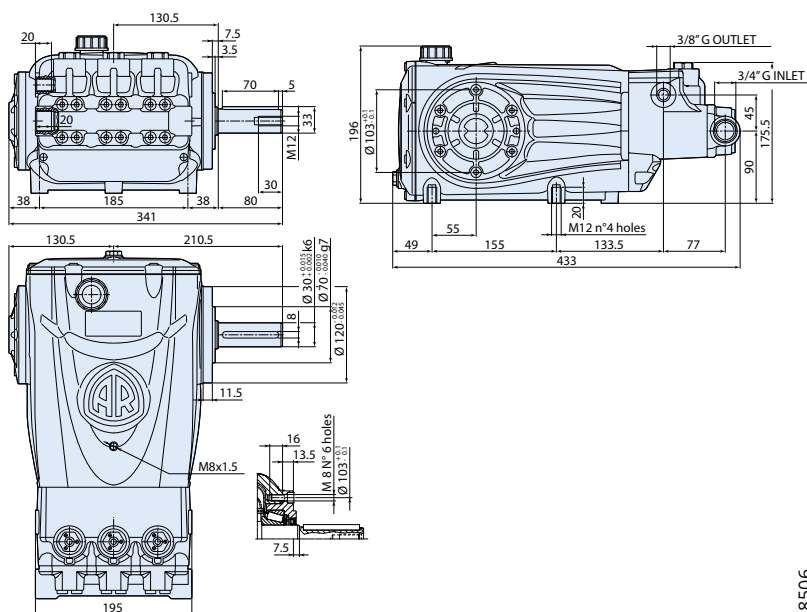

3668506

N version

MOD	COD	MAX	MAX		
		l/min gpm	bar psi	hp kW	N° giri/1' kg
RTX 1450rpm Nversion Ø30mm					
RTX 30.500 N	26116	30 7,92	500 7250	40 30	1450 34



testa nichelata
nickel plated brass head



bielle in bronzo
connecting-rods in bronze

366 Series

POMPA ALBERO MASCHIO Solid shaft pump



lavaggio industriale
industrial cleaning



processi industriali
industrial processes



autolavaggio
car wash



produzione
manufacturing



agricoltura
agriculture



municipality



misting



pulizia tubazioni
sewer jetting

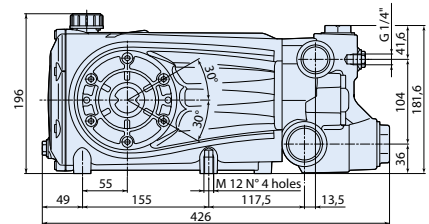
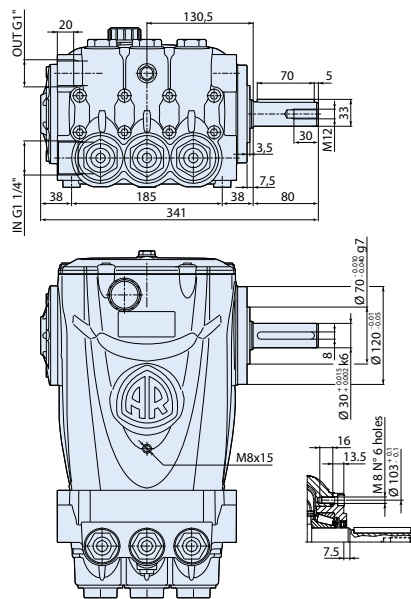

N version

MOD	COD	MAX	MAX						
		l/min	gpm	bar	psi	hp	kW	N° giri/1'	kg
RTX 1450rpm Nversion Ø30mm									
RTX 150.100 N	26485	150	39,6	100	1450	30	22	1450	35

NEW



testa nichelata
nickel plated brass head



bielle in bronzo
connecting-rods in bronze

3668509

RTX-I

366 SERIES

RTX-I Stainless Steel ad alta pressione
fino a 500 bar.

- Albero in acciaio ad alta resistenza e supportato da due **cuscinetti a rulli conici** di alta qualità e sovradimensionati.
- Bielle in **bronzo**.
- Corpo pompa e coperchi laterali in lega di **alluminio ad alta resistenza** per pressofusione e con trattamento di **anodizzazione**.
- Pistoni in **ceramica** integrale.
- Sistema di tenuta a **doppia guarnizione**.
- Testa in **acciaio inox** AISI 420.
- **Valvole di costruzione robusta** per reggere le alte pressioni di utilizzo.
- Coperchio posteriore con **scarico olio**.
Livello olio laterale.

RTX-I Stainless Steel pump up to 500 bar.

- *Shaft in high-strength steel supported by two **high-quality, oversized tapered roller bearings**.*
- ***Bronze** connecting rods.*
- *Pump head in **stainless steel** AISI 420.*
- *Body and side covers in **anodised die-cast high-strength aluminium alloy**.*
- ***Ceramic pistons**.*
- ***Double gasket sealing system**.*
- ***Valves** are of **rugged construction** to withstand the high operating pressures.*
- *Back cover incorporated with **oil drain outlet**.
Lateral oil sight glass.*

NEW

**AISI
420**

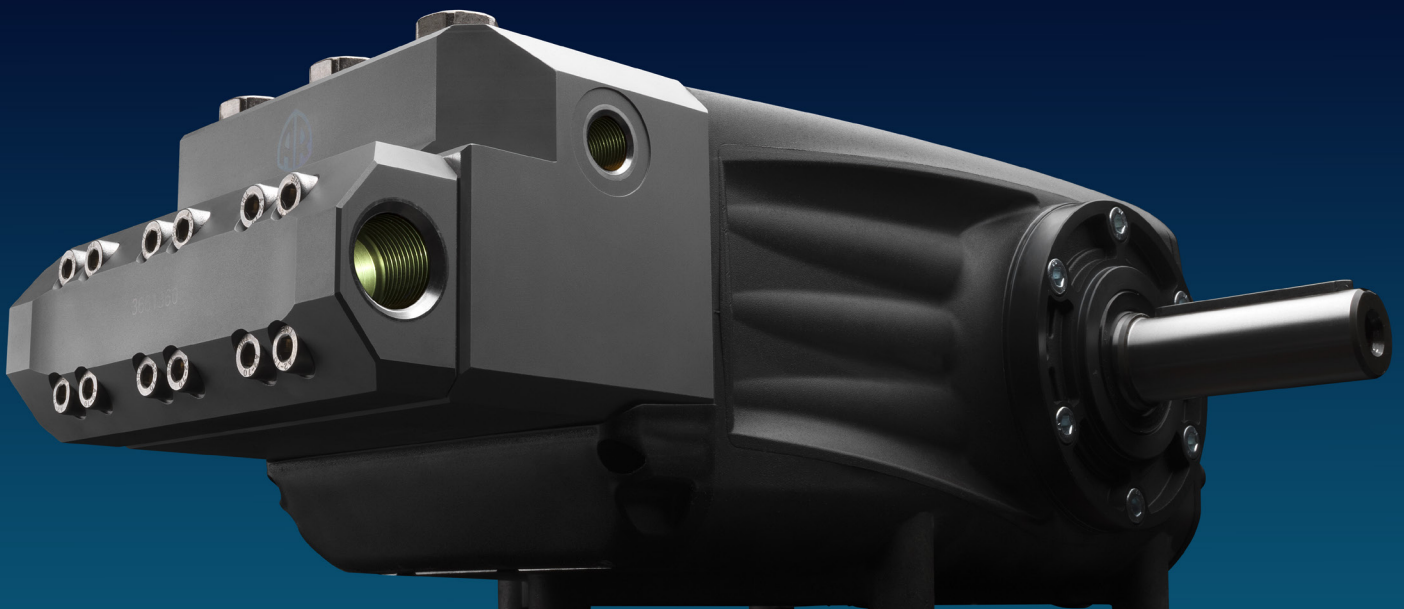

366 Series

POMPA ALBERO MASCHIO Solid shaft pump



lavaggio industriale
industrial cleaning



processi industriali
industrial processes



municipality



pulizia tubazioni
sewer jetting



cantieri ed edilizia
construction industry



settore navale
marine industry

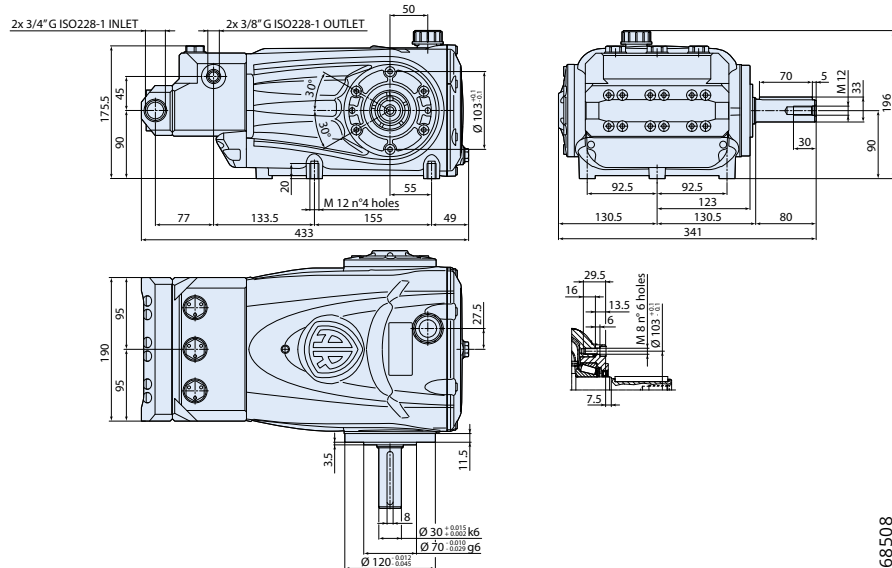

3668508

N version

MOD	COD	MAX	MAX						
		l/min	gpm	bar	psi	hp	kW	N° giri/1'	kg

RTX-I 1450rpm Nversion Ø30mm

RTX-I 30.500 N **26611** 30 7,92 500 7250 40 30 1450 34

NEW



testa in inox
inox head



bielle in bronzo
connecting-rods in bronze



366 Series

ELECTRIC MOTOR-PUMP UNITS

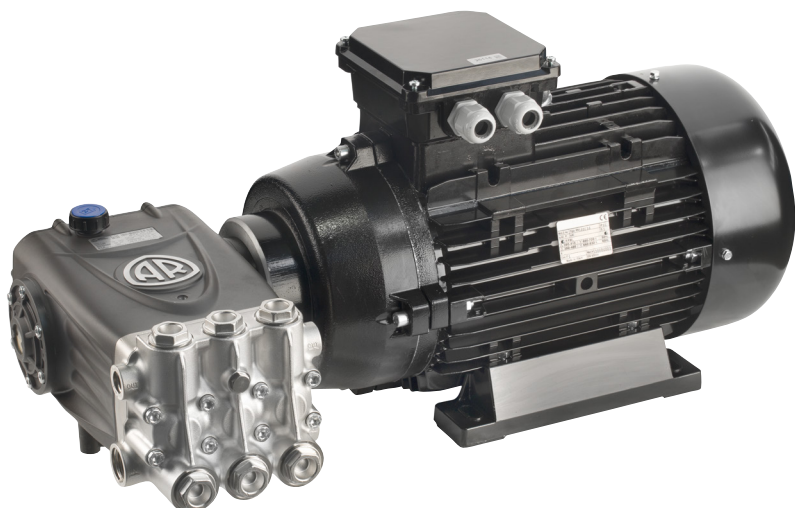

Motore elettrico GR. 160L con giunto flessibile interno.
GR. 160L electric motor with internal flexible joint.

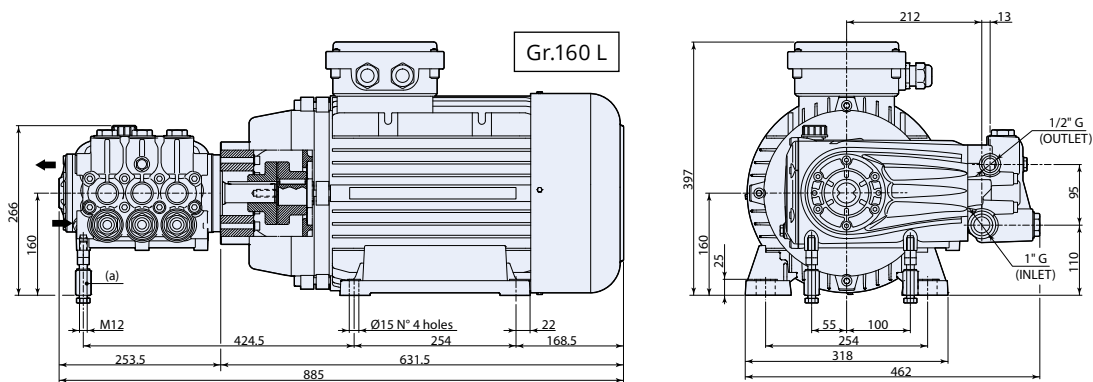

3668501

MOD	COD	MAX		MAX						KG NET	
	3 ~	l/min	gpm	bar	psi	hp	kW	N° giri/1'	V 3-50Hz	Gr.	kg
HRTX 1450 rpm											
HRTX 30.300 ET	25344	30	7,92	300	4350	25	18,6	1450	400/690	160 L	135
HRTX 50.200 ET	25257	50	13,2	200	2900	25	18,6	1450	400/690	160 L	135
HRTX 70.150 ET	25664	70	18,5	150	2200	30	22	1450	400/690	160 L	135
HRTX 100.120 ET	25665	100	26,4	120	1740	30	22	1450	400/690	160 L	135



testa in nickel
nickel plated head



bielle in alluminio
Connecting rods in aluminum



3~50Hz
frequenza motore
motor frequency

366 Series

ELECTRIC MOTOR-PUMP UNITS

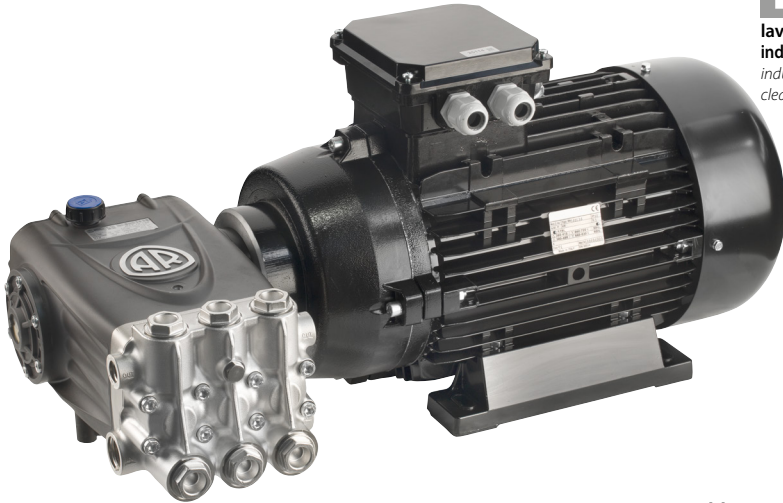



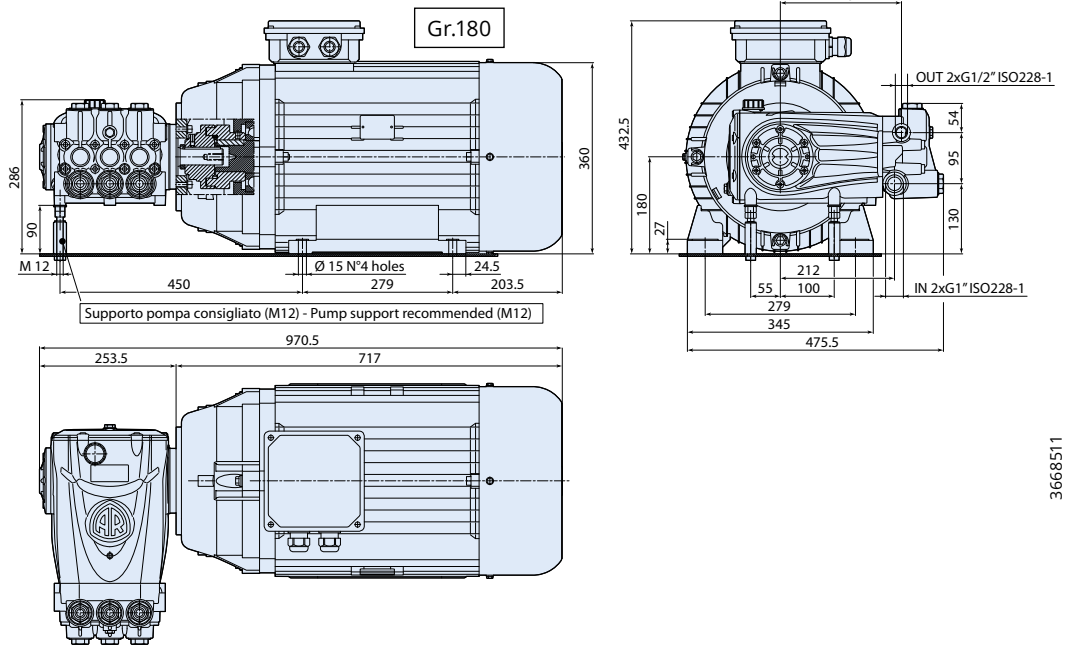

- 
lavaggio industriale
industrial cleaning
- 
processi industriali
industrial processes
- 
autolavaggio
car wash
- 
produzione
manufacturing
- 
agricoltura
agriculture
- 
municipality
- 
misting
- 
pulizia tubazioni
sewer jetting

Motore elettrico GR. 180 con giunto flessibile interno.
GR. 180 electric motor with internal flexible joint.



3668511

NEW

MOD	COD	 MAX	 MAX		 NET						
	3 ~	l/min	gpm	bar	psi	hp	kW	N° giri/1'	V 3-50Hz	Gr.	kg
HRTX 1450 rpm											
HRTX 50.200 ET	26923	50	13,2	200	2900	40	30	1450	400/690	180	220
HRTX 60.250 ET	26924	60	15,9	250	3600	40	30	1450	400/690	180	220



testa in nickel
nickel plated head



bielle in alluminio
connecting-rods in aluminum



frequenza motore
motor frequency



366 Series

ELECTRIC MOTOR-PUMP UNITS



lavaggio industriale
industrial cleaning



processi industriali
industrial processes



produzione
manufacturing



municipality



Motore elettrico GR. 180 con giunto flessibile interno.
GR. 180 electric motor with internal flexible joint.

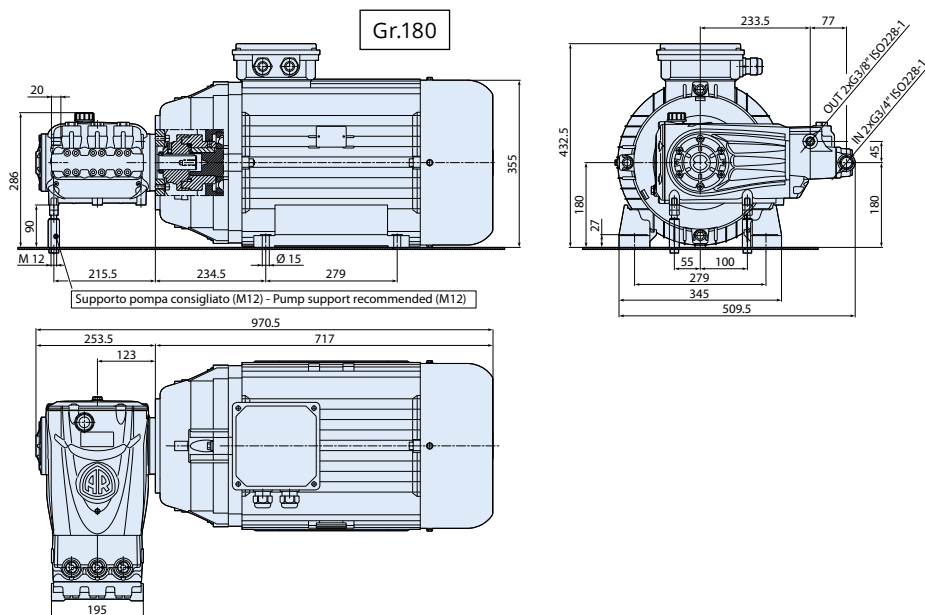

3668510

NEW

MOD	COD	MAX	MAX								
	3 ~	l/min	gpm	bar	psi	hp	kW	N° giri/1'	V 3-50Hz	Gr.	kg
HRTX 1450rpm											
HRTX 30.500 ET	26922	30	7,92	500	7250	40	30	1450	400/690	180	221



testa nichelata
nickel plated brass head



bielle in bronzo
connecting-rods in bronze



frequenza motore
motor frequency

366 Series

HYDRAULIC DRIVE



municipality



antincendio
fire fighting



Motor Type	A	B	C	D	E	F	G
	mm						Ø mm
SNM3NN/044 BN07GAM1A4A4 NNNN/NNNNN	71	148,5	558	30,18	58,72	7/16- 14 UNC	31,8

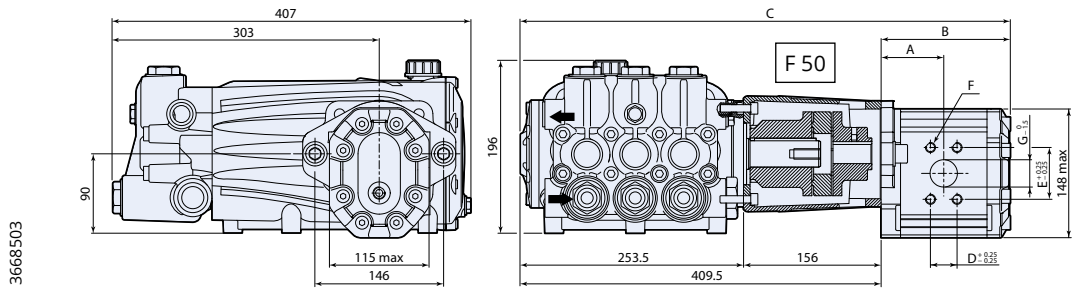

3668503



testa
nichelata
nickel plated
brass head



bielle in
alluminio
connecting-rods
in aluminium



motore
idraulico
hydraulic
drive

HYD - RTX

MOD	COD	POMPA A PISTONI • HP PISTON PUMP						MOTORE IDRAULICO • HYDRAULIC MOTOR						
		MAX		MAX		RPM	⚡	SAUER DANFOSS			MAX	MAX	RPM	KG NET
		l/min	gpm	bar	psi	N° giri/1'	hp	Type	Cod	cm³	bar	l/min	N° giri/1'	kg
HYD-XTX														
HYD-RTX 70.150	25549	70	18,5	150	2200	1450	30	NM3NN/044 BN07GAM1A4A4 NNNN/NNNNN	44741	44,1	180*	70*	1450	42,5
HYD-RTX 70.200	26148	70	18,5	200	2900	1450	37	SNM3NN/044 BN07GAM1A4A4 NNNN/NNNNN	44741	44,1	240*	70*	1450	42,5
HYD-RTX 100.120	25345	100	26,4	120	1740	1450	30	NM3NN/044 BN07GAM1A4A4 NNNN/NNNNN	44741	44,1	210*	70*	1450	42,5

*) Theoretical data.

418 SERIES

RTD
RTD-L



Corpo e coperchi in alluminio pressofuso.

Coperchio posteriore con scarico e livello olio.

Livello olio laterale.

Cuscinetti a rulli conici.

Bielle in lega zinco-alluminio o in bronzo.

Testa in ottone stampato. Possibilità di testa in ottone nichelata.

Pistoni in ceramica.

Pump body and cover in pressure die-cast aluminium alloy.

Back cover incorporated with oil sight glass and oil drain outlet.

Additional side oil sight glass.

Tapered roller bearings.

Connecting rods in die-cast zinc-aluminium alloy. Bronze connecting rods available.

Pump head in forged brass. Nickel-plated brass head available.

Ceramic pistons.

418 Series

POMPA ALBERO MASCHIO Solid shaft pump



lavaggio industriale
industrial cleaning



processi industriali
industrial processes



produzione
manufacturing



agricoltura
agriculture



municipality

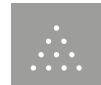

misting



pulizia tubazioni
sewer jetting



cantieri ed edilizia
construction industry





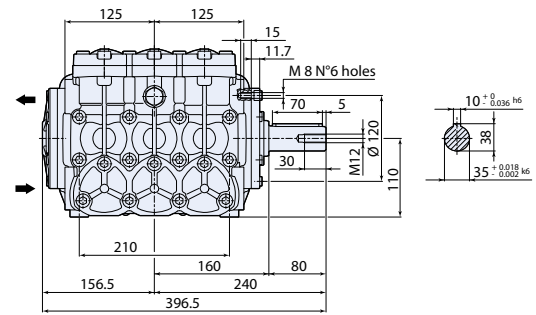
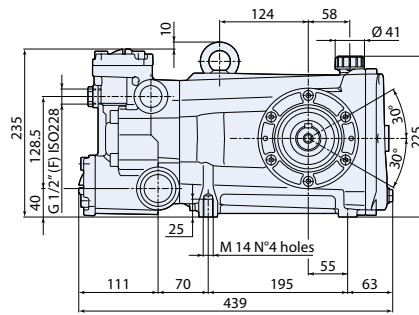

antincendio
fire fighting

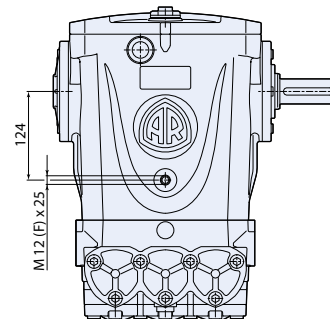
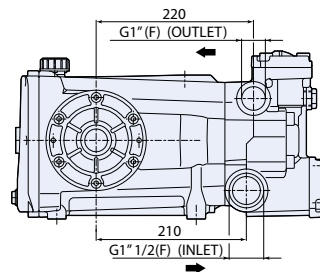

4188500



N version

MOD	COD	 MAX	 MAX						
		l/min	gpm	bar	psi	hp	kW	N° giri/1'	kg
RTD - L 800rpm Nversion Ø35mm									
RTD-L 160.100 N	25346	155	40,9	100	1450	42	32	800	58
RTD 1000rpm Nversion Ø35mm									
RTD 80.280 N	26875	80	21,1	280	4060	59	44	1000	58
RTD 100.200 N	26327	100	26,4	200	2900	54	41	1000	58
RTD 130.100 N	25348	130	34,5	100	1450	34	26	1000	58
RTD 130.160 N	26105	130	34,5	160	2300	54	41	1000	58
RTD 160.100 N	25347	160	42,3	100	1450	42	32	1000	58
RTD 160.130 N	26104	160	42,3	130	1900	54	41	1000	58



testa in ottone
brass head



bielle in bronzo
connecting-rods in bronze



bielle in alluminio
connecting-rods in aluminium

A richiesta testa nichelata. · Nickel plated head available.

282 SERIES

RTP
RTJ
RTF

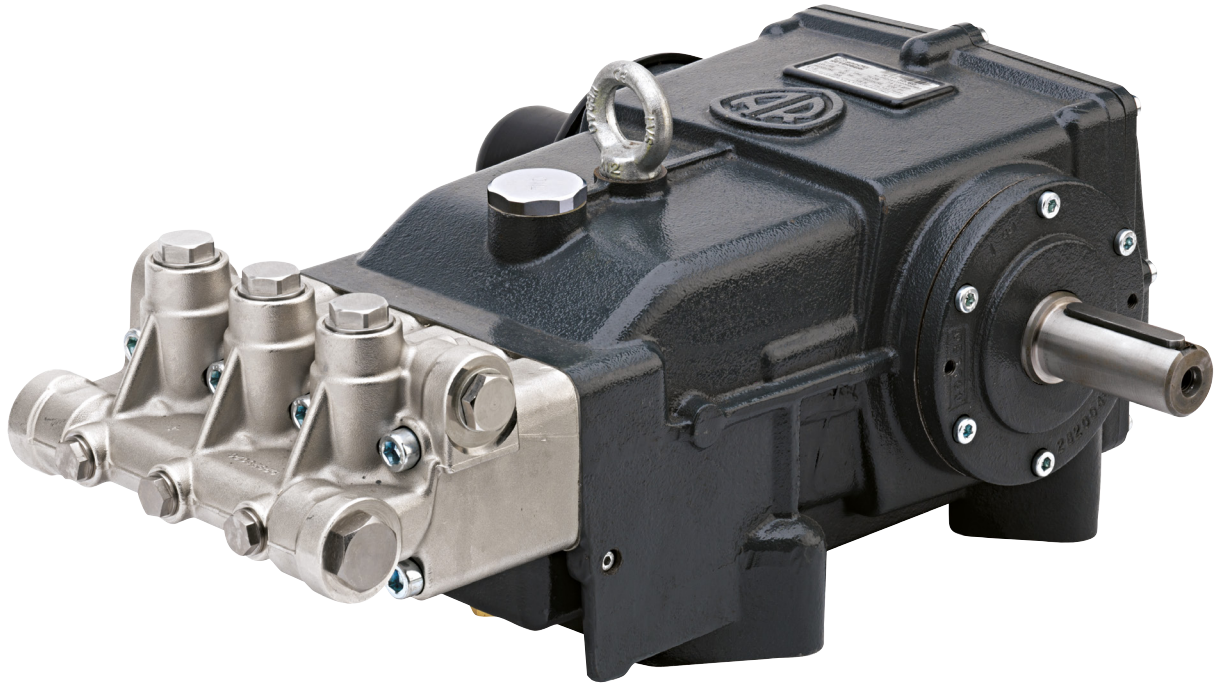

Corpo in ghisa.

Livello olio nel coperchio posteriore e tappo magnetico per recupero residui metallici.

Bielle in bronzo.

Albero passante.

Testa in ottone nichelato.

Triplo sistema di tenute acqua.

Cast iron pump body.

Back cover incorporated with oil sight glass. Magnetic discharge oil cap to attract all the microscopic metal particles arising from heavy duty usage.

Bronze connecting rods.

Through shaft.

Nickel-plated brass pump head.

Triple water seals.

282 Series

POMPA ALBERO MASCHIO Solid shaft pump

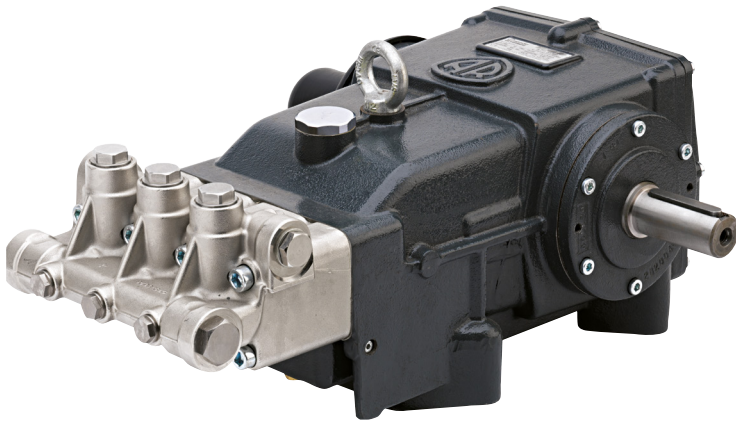

lavaggio industriale
industrial cleaning



municipality



pulizia tubazioni
sewer jetting



cantieri ed edilizia
construction industry



antincendio
fire fighting

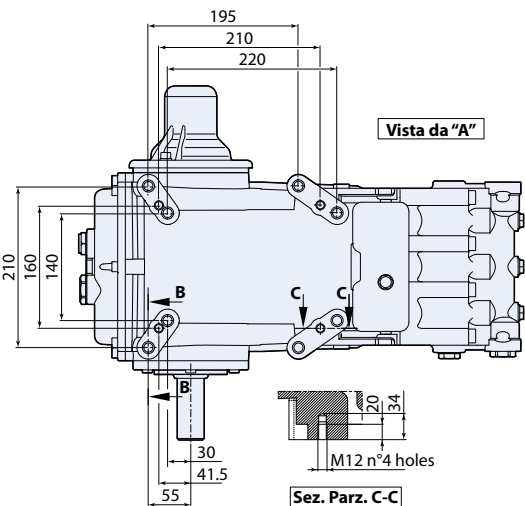
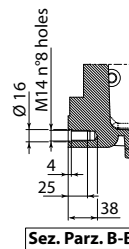
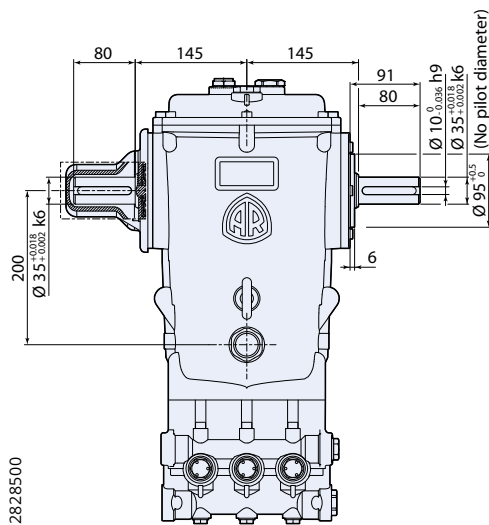
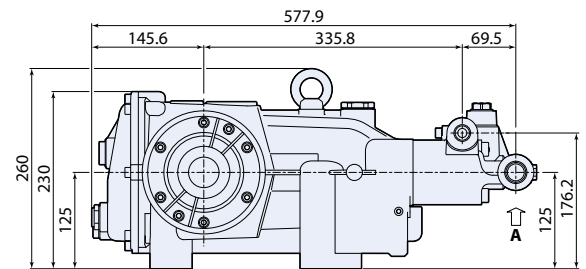
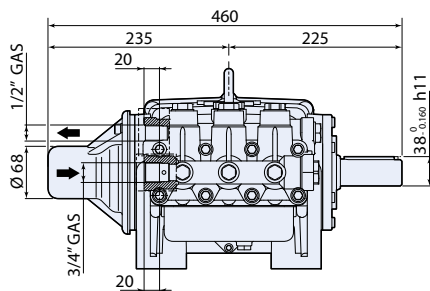

N version

MOD	COD	MAX	MAX						
		l/min	gpm	bar	psi	hp	kW	N° giri/1'	kg
RTP 1000rpm Nversion Ø35mm									
RTP 30.500 N AP	22215	30	7,92	500	7250	40	30	1000	78
RTP 38.500 N AP	22216	38	10	500	7250	51	38	1000	78
RTP 30.600 N AP *	22982	30	7,92	600	8702	48	36	1000	78



testa nichelata
nickel plated
brass head



bielle in bronzo
connecting-rods
in bronze

* A richiesta disponibile con testa in acciaio AISI 420.
On request available AISI 420 stainless steel head.



282 series

POMPA ALBERO MASCHIO Solid shaft pump



lavaggio industriale
industrial cleaning



processi industriali
industrial processes



municipality



pulizia tubazioni
sewer jetting



cantieri ed edilizia
construction industry



antincendio
fire fighting

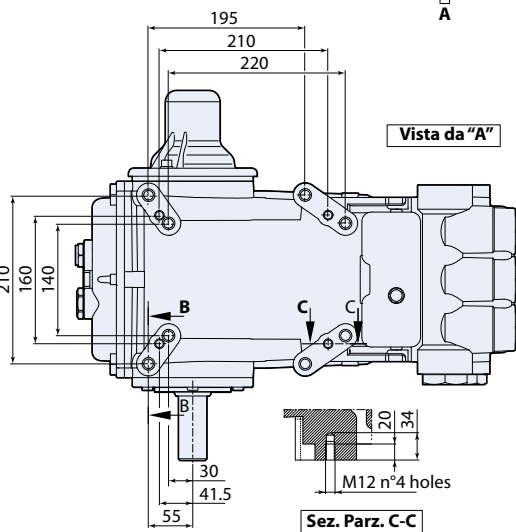
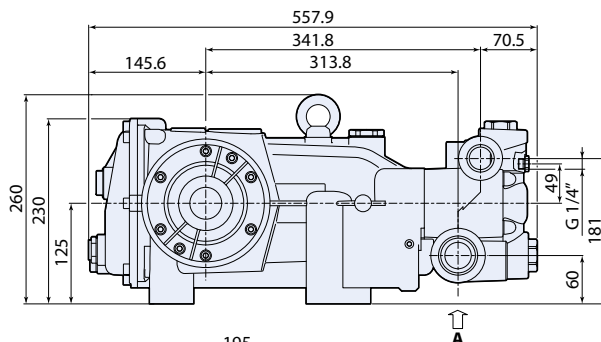
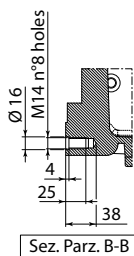
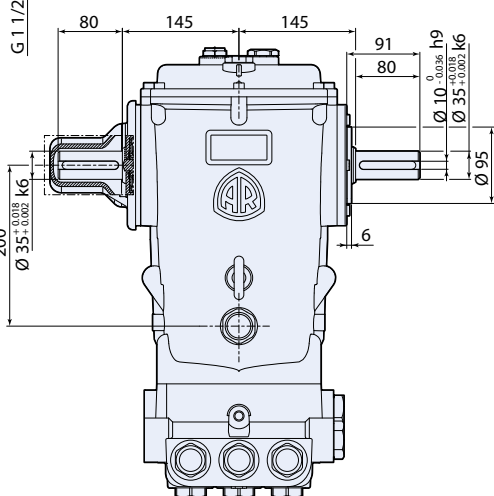
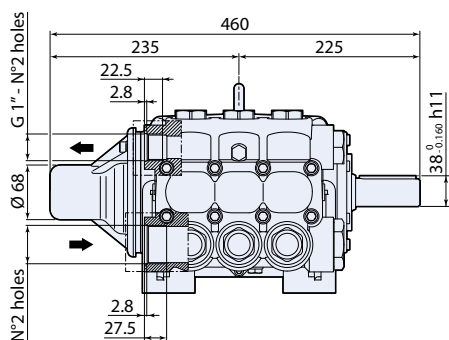

2828502

N version

MOD	COD	MAX	MAX		NET				
		l/min	gpm	bar	psi	hp	kW	N° giri/1'	kg
RTJ 1000rpm Nversion Ø35mm									
RTJ 70.275 N AP	22817	70	18,5	275	4000	51	38	1000	90



testa nichelata
nickel plated brass head



bielle in bronzo
connecting-rods in bronze

282 Series

POMPA ALBERO MASCHIO Solid shaft pump



lavaggio industriale
industrial cleaning

autolavaggio municipalità
car wash

misting

CAR WASH

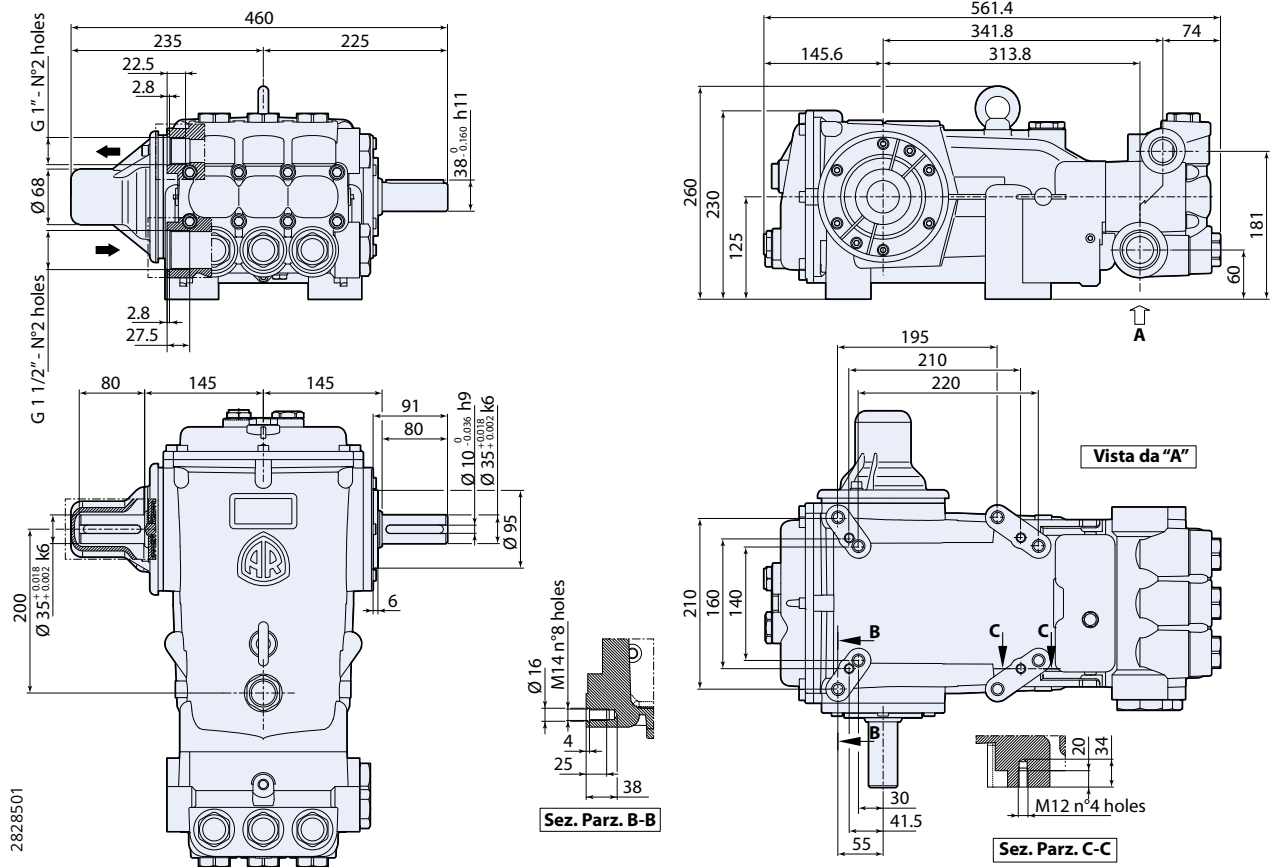

N version

MOD	COD	MAX	MAX						
		l/min	gpm	bar	psi	hp	kW	N° giri/1'	kg
RTF 800rpm Nversion $\varnothing 35$mm									
RTF 135.100 N AP	22217	135	35,7	100	1450	35	26	800	90
RTF 150.100 N AP	24381	150	39,6	100	1450	39	29	800	90



testa nichelata
nickel plated
brass head



bielle in bronzo
connecting-rods
in bronze

STAINLESS STEEL

XM-SS
XMA-SS
RK-SS
HYD RK-SS
RKA-SS

XWL-SS
RTX-SS



**AISI
316 L**

Corpo pompa in alluminio pressofuso e sottoposto poi a trattamento di verniciatura in cataforesi.

Testa lavorata dal pieno in acciaio AISI-316L per resistere ad atmosfere saline e acide.

Bielle in lega zinco-alluminio o in bronzo.

Albero in acciaio stampato e trattato termicamente per garantire elevata resistenza meccanica.

Pistoni in ceramica.

Pump body in pressure die-cast aluminium alloy with cathodolysis treatment.

Head machined from solid AISI 316L steel billet for resistance to saline and acid environments.

Connecting rods in pressure die-cast zinc-aluminium alloy. Bronze connecting rods available.

Shaft in heat-treated pressed steel for excellent mechanical strength.

Ceramic pistons.

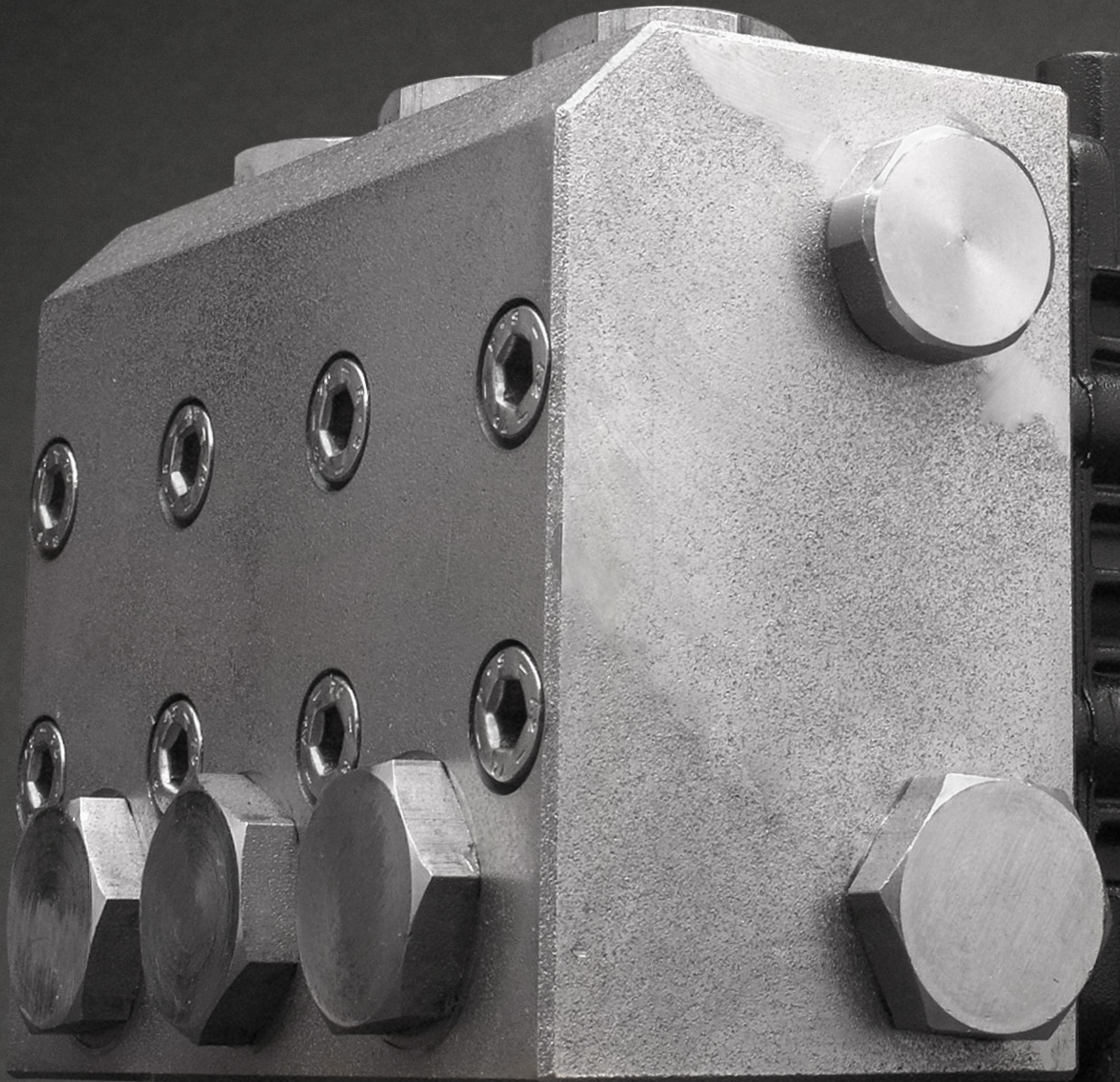



Stainless Steel

POMPA ALBERO MASCHIO Solid shaft pump



industria
alimentare
food
industry



settore
navale
marine
industry

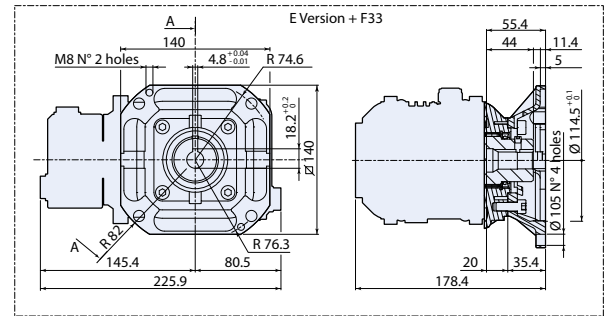
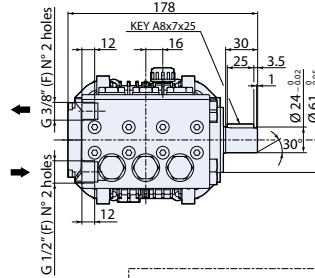
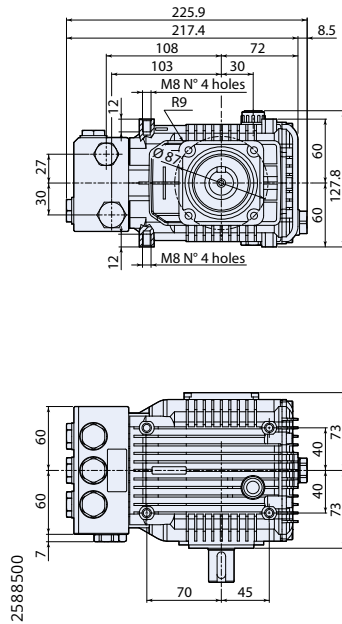
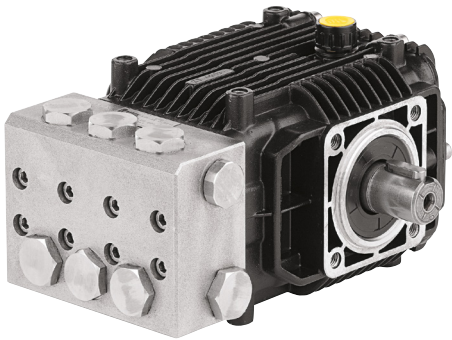

N version

MOD	COD	MAX	MAX						
		l/min	gpm	bar	psi	hp	kW	N° giri/1'	kg
XM - SS 1450rpm Nversion Ø24mm									
XM-SS 11.17 N	22124	11	2,90	170	2500	5	3,7	1450	7



testa in
inox
inox
head



bielle in
bronzo
connecting-rods
in bronze

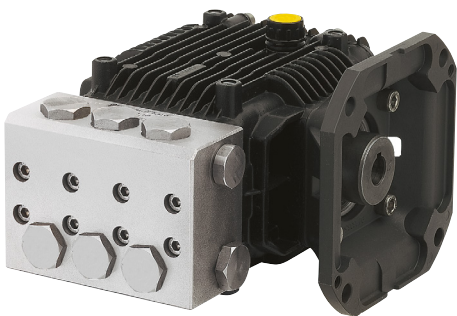

POMPA ALBERO CAVO Hollow shaft pump



industria
alimentare
food
industry



settore
navale
marine
industry

E version + F33

MOD	COD	MAX	MAX						
		l/min	gpm	bar	psi	hp	kW	N° giri/1'	kg
XMA-SS 1750rpm Eversion + F33 Ø 5/8"									
XMA-SS 0.5G15 E + F33	21435	1,9	0,5	103	1500	0,6	0,4	1750	7
XMA-SS 2.5G15 E + F33	21436	9,5	2,5	103	1500	2,5	1,8	1750	7
XMA-SS 3G15 E + F33	21437	11,4	3	103	1500	3	2,2	1750	7



testa in
inox
inox
head



bielle in
bronzo
connecting-rods
in bronze

Flangia F33 per motori elettrici NEMA 56-C, 4 poli 60Hz. Flangia inclusa.
F33 flange for electric motor NEMA 56-C, 4 poles 60Hz Flange included.

Stainless Steel

POMPA ALBERO MASCHIO Solid shaft pump

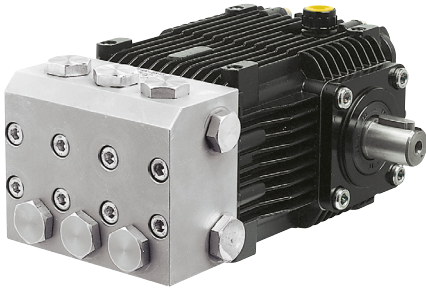

industria
alimentare
food
industry

settore
navale
marine
industry

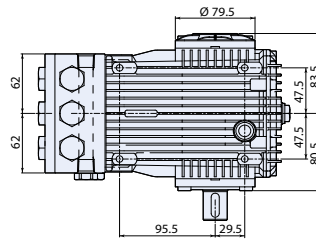
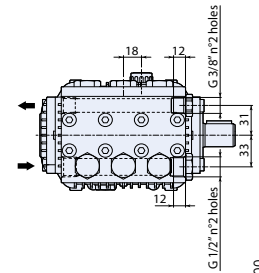
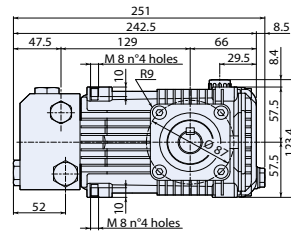
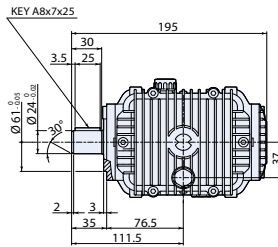

2348500

N version

MOD	COD	MAX		MAX				N° giri/1'	KG NET
		l/min	gpm	bar	psi	hp	kW		
RK - SS 1450rpm Nversion Ø24mm									
RK-SS 11.11 N	20958	11	2,90	110	1600	3	2,2	1450	10
RK-SS 13.17 N	20959	13	3,43	170	2500	5,5	4	1450	10
RK-SS 15.15 N	20960	15	3,96	150	2200	5,5	4	1450	10
RK-SS 21.15 N	21368	21	5,55	150	2200	7,5	5,5	1450	10



testa in
inox
inox
head



bielle in
bronzo
connecting-rods
in bronze

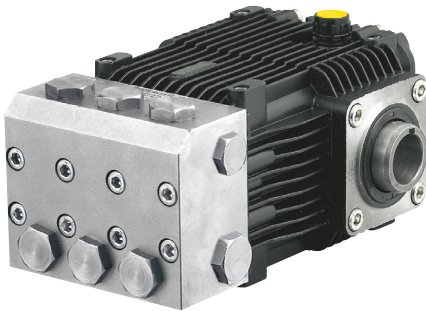

POMPA ALBERO CAVO Hollow shaft pump

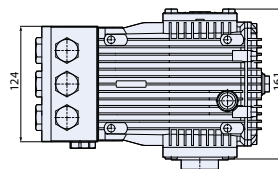
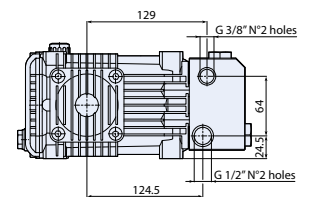
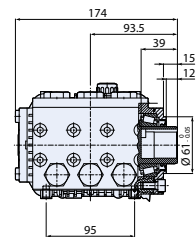
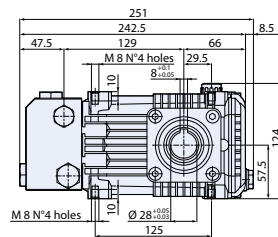

industria
alimentare
food
industry

settore
navale
marine
industry

C version

MOD	COD	MAX		MAX				N° giri/1'	KG NET
		l/min	gpm	bar	psi	hp	kW		
RK-SS 1450rpm Cversion Ø 28mm									
RK-SS 11.11 C	20961	11	2,90	110	1600	3	2,2	1450	10
RK-SS 13.17 C	20962	13	3,43	170	2500	5,5	4	1450	10
RK-SS 15.15 C	20963	15	3,96	150	2200	5,5	4	1450	10
RK-SS 21.15 C	21369	21	5,55	150	2200	7,5	5,5	1450	10



testa in
inox
inox
head



bielle in
bronzo
connecting-rods
in bronze

Flangia F16 per motori elettrici B14 Gr.100÷112 IEC34-7, 4 poli 50Hz. Flangia non inclusa.
F16 flange for electric motor B14 100÷112 IEC34-7, 4 poles 50Hz. Flange not included.

2348511



Stainless Steel

HYDRAULIC DRIVE



municipality
settore
navale
marine
industry

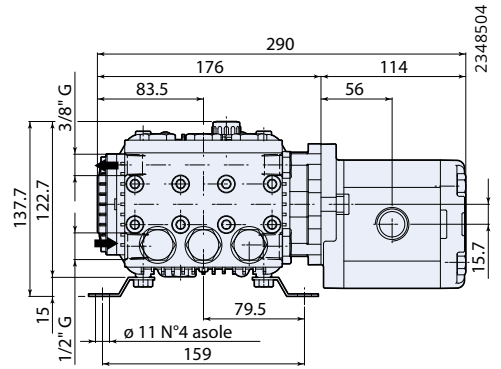
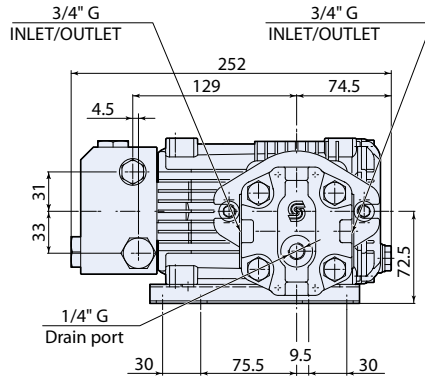
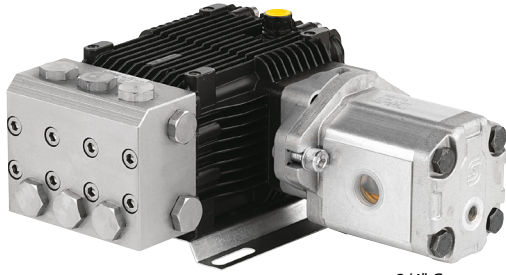

- testa in inox
inox head
- bielle in bronzo
connecting-rods in bronze
- motore idraulico
hydraulic drive

HYD RK-SS

MOD	COD	HP PISTON PUMP • POMPA A PISTONI					HYDRAULIC MOTOR • MOTORE IDRAULICO					KG NET		
		MAX	MAX	RPM	hp	SAUER DANFOSS (*)	MAX	MAX	RPM	kg				
		l/min	gpm	bar	psi	N° giri/1'	hp	Type	Cod	cm ³	bar	l/min	N° giri/1'	kg

HYD RK-SS 1450rpm

HYD RK-SS 21.15 **21965** 21 5,55 150 2200 1450 7,5 SNM 2NN/019 BN06 4769 19,2 150 29 1450 13,5

* A richiesta disponibili motori idraulici Casappa - Marzocchi.
On request available Hydraulic Motor type: Casappa - Marzocchi.

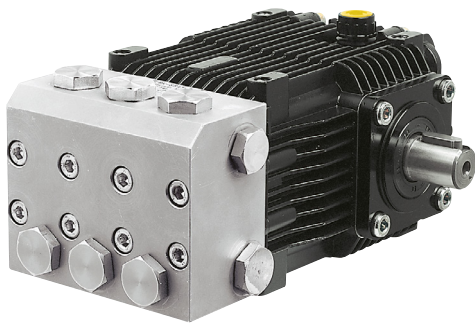

POMPA ALBERO MASCHIO Solid shaft pump

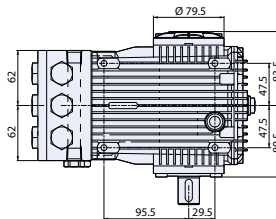
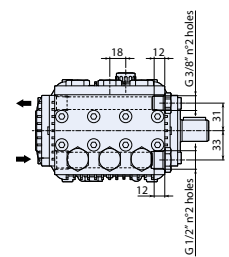
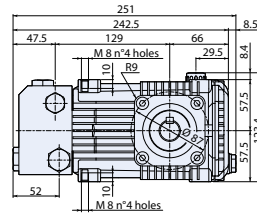
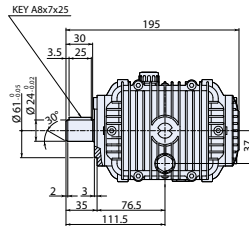

industria alimentare
food industry

settore navale
marine industry

N version

MOD	COD	MAX	MAX					KG NET
		l/min	gpm	bar	psi	hp	kW	

RKA-SS 1750rpm Nversion Ø24mm

RKA-SS 2.3 G15 N	20964	8,7	2,3	103	1500	2,4	1,8	1750	10
RKA-SS 3 G15 N	20965	11,4	3	103	1500	3	2,2	1750	10
RKA-SS 3.6 G12 N	20966	13,6	3,6	83	1200	3	2,2	1750	10
RKA-SS 4.2 G15 N	20967	15,9	4,2	103	1500	4,3	3,2	1750	10
RKA-SS 7 G22 N	21195	27	7,1	150	2200	11	8,2	1750	10



testa in inox
inox head

bielle in bronzo
connecting-rods in bronze

2348500

Stainless Steel

POMPA ALBERO CAVO Hollow shaft pump

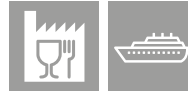
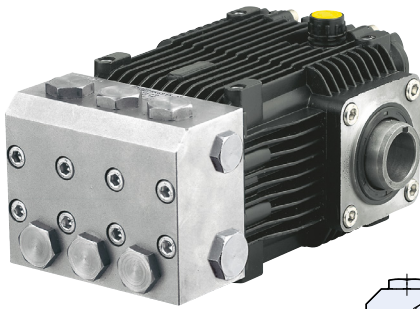

industria
alimentare
food
industry

settore
navale
marine
industry

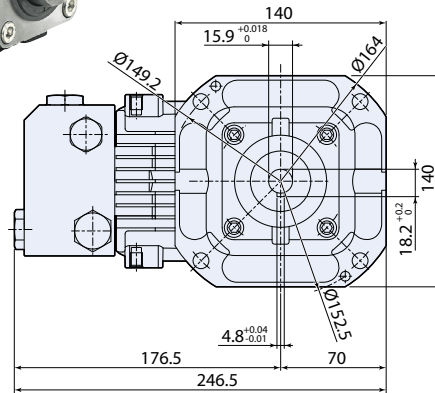

2348501

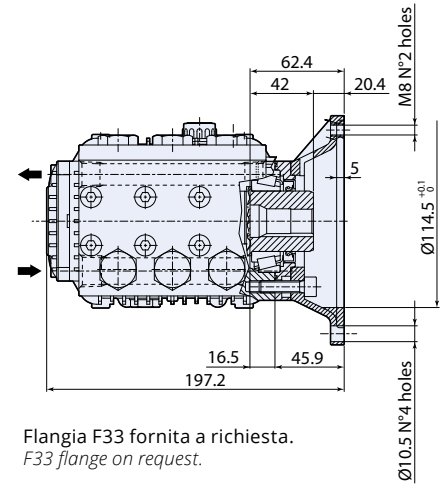

Flangia F33 fornita a richiesta.
F33 flange on request.

E version

MOD	COD	MAX	MAX			N°			
		l/min	gpm	bar	psi	hp	kW	giri/1'	kg
RKA-SS 1750rpm E version Ø 5/8"									
RKA-SS 2.3 G15 E	20968	8,7	2,3	103	1500	2,4	1,8	1750	10
RKA-SS 3 G15 E	20969	11,4	3	103	1500	3	2,2	1750	10
RKA-SS 3.6 G12 E	20970	13,6	3,6	83	1200	3	2,2	1750	10
RKA-SS 4.2 G15 E	20971	15,9	4,2	103	1500	4,3	3,2	1750	10



testa in
inox
inox
head



bielle in
bronzo
connecting-rods
in bronze

Flangia F33 per motori elettrici NEMA 56-C,
4 poli 60Hz. Flangia non inclusa.
F33 flange for electric motor NEMA 56-C, 4 poles
60Hz Flange not included.

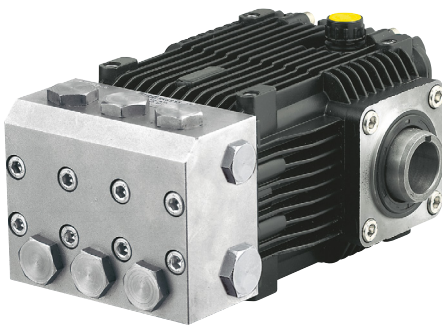

POMPA ALBERO CAVO Hollow shaft pump



industria
alimentare
food
industry

settore
navale
marine
industry

2348502

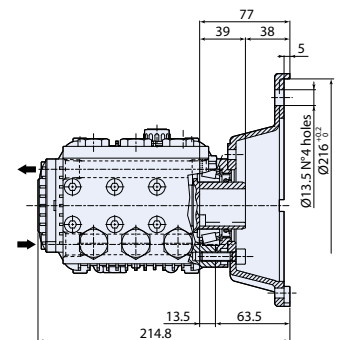
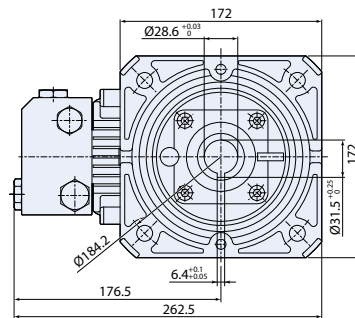

Flangia F17 fornita a richiesta.
F17 flange on request.

E version

MOD	COD	MAX	MAX			N°			
		l/min	gpm	bar	psi	hp	kW	giri/1'	kg
RKA-SS 1750rpm E version Ø 1" 1/8									
RKA-SS 2.3 G15 E	20972	8,7	2,3	103	1500	2,4	1,8	1750	10
RKA-SS 3 G15 E	20973	11,4	3	103	1500	3	2,2	1750	10
RKA-SS 3.6 G12 E	20974	13,6	3,6	83	1200	3	2,2	1750	10
RKA-SS 4.2 G15 E	20975	15,9	4,2	103	1500	4,3	3,2	1750	10



testa in
inox
inox
head



bielle in
bronzo
connecting-rods
in bronze

Flangia F17 per motori elettrici NEMA 182÷184,
4 poli 60Hz. Flangia non inclusa.
F17 Flange for electric motor NEMA 182÷184,
4 poles 60Hz. Flange not included.



Stainless Steel

POMPA ALBERO MASCHIO Solid shaft pump



industria
alimentare
food
industry



settore
navale
marine
industry

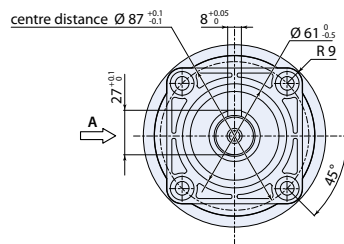
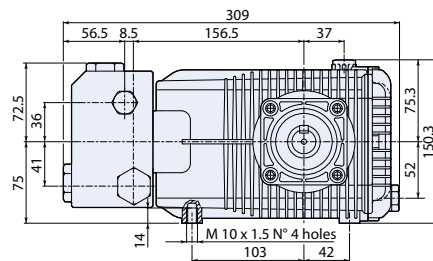
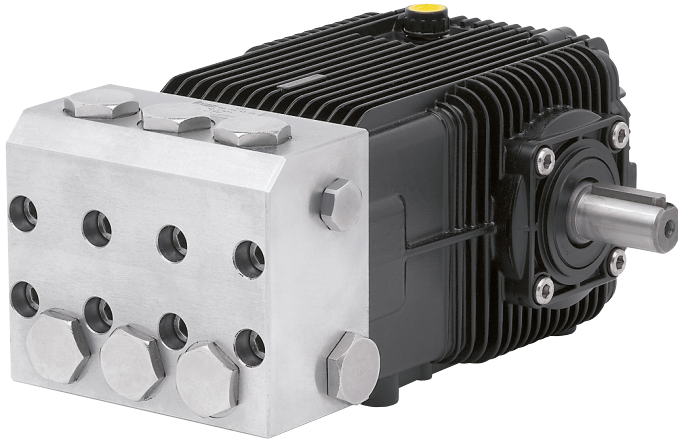

2528500

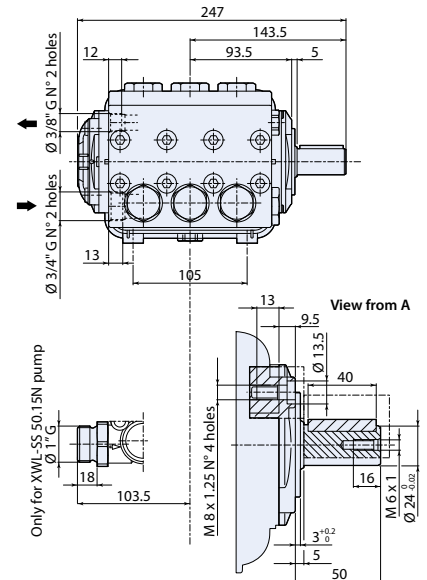

N version

MOD	COD	MAX		MAX		hp	kW	N° giri/1'	kg NET	
		l/min	gpm	bar	psi					
XWL - SS 950rpm Nversion Ø24mm										
XWL-SS 33.06 N	22831	33	8,72	60	900	5,5	4	950	18	
XWL-SS 33.08 N	23141	33	8,72	80	1160	7,5	5,5	950	18	
XWL - SS 1450rpm Nversion Ø24mm										
XWL-SS 26.06 N	22478	26	6,87	60	900	4	3	1450	18	
XWL-SS 30.09 N	22752	30	7,92	90	1300	7,5	5,5	1450	18	
XWL-SS 42.05 N	21468	42	11,09	50	725	5,5	4	1450	18	
XWL-SS 42.15 N	21704	42	11,09	150	2200	15	11	1450	18	
XWL-SS 50.15 N *	24105	50	13,20	150	2200	20	15	1450	18	

* Minimo +0,1 bar (+1,5 psi) di pressione in entrata. • Min. +0,1 bar (+1,5 psi) inlet pressure.



testa in
inox
inox
head



bielle in
alluminio
connecting-rods
in aluminium

Stainless Steel

POMPA ALBERO MASCHIO Solid shaft pump



**industria
alimentare**
food
industry

**settore
navale**
marine
industry

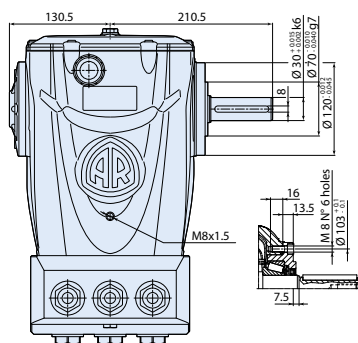
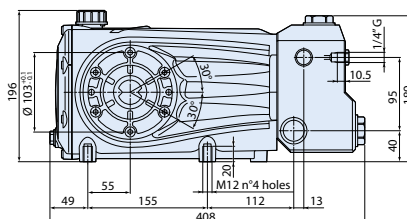
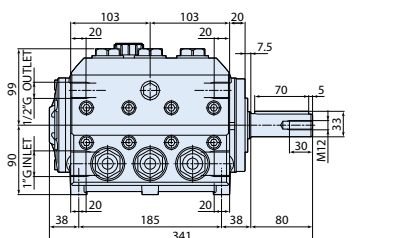

4048500

N version

MOD	COD	MAX	MAX		NET				
		l/min	gpm	bar	psi	hp	kW	N° giri/1'	kg
RTX - SS 1450rpm	Nversion	Ø30mm							
RTX-SS 100.100 N	26136	100	26,4	100	1450	24	18	1450	39



**testa in
inox**
inox
head



**bielle in
alluminio**
connecting-rods
in aluminium

ADDITIONAL ELECTRIC MOTOR

HPV
HPV-O
HPV-MO
HPE
HPE-M

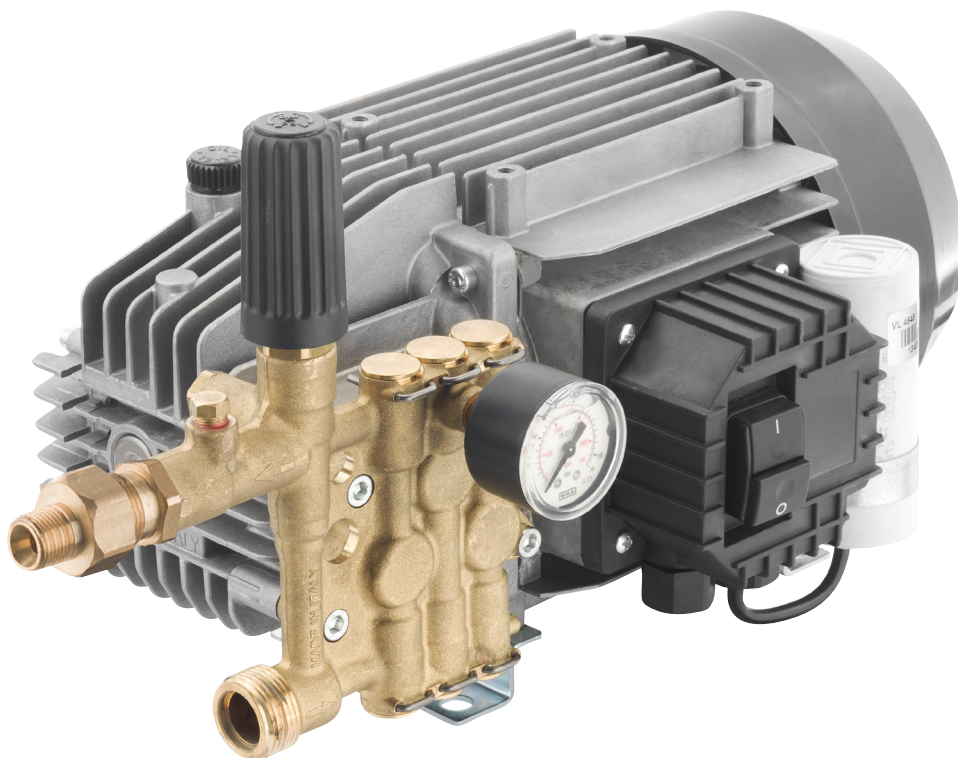

Corpo in lega di alluminio ad alta resistenza.

Pump body in high-strength aluminium alloy.

Testa in ottone o alluminio.

Pump head in brass or aluminium.



idropultrici
pressure
washers

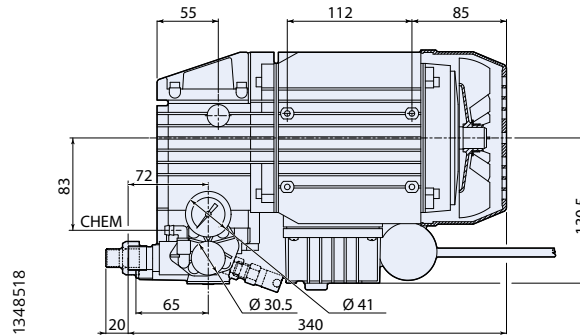
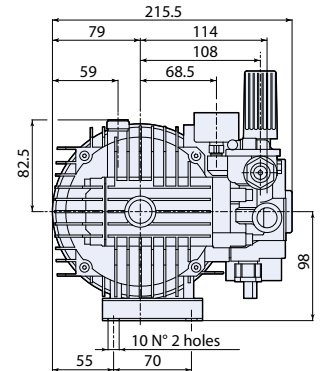
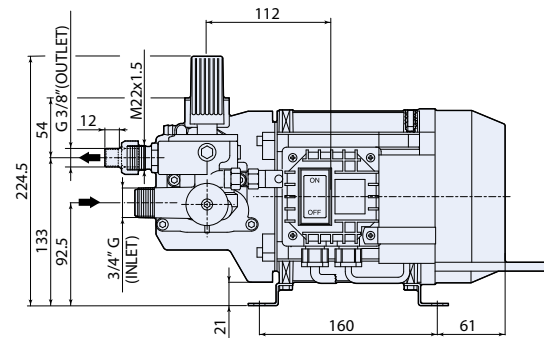
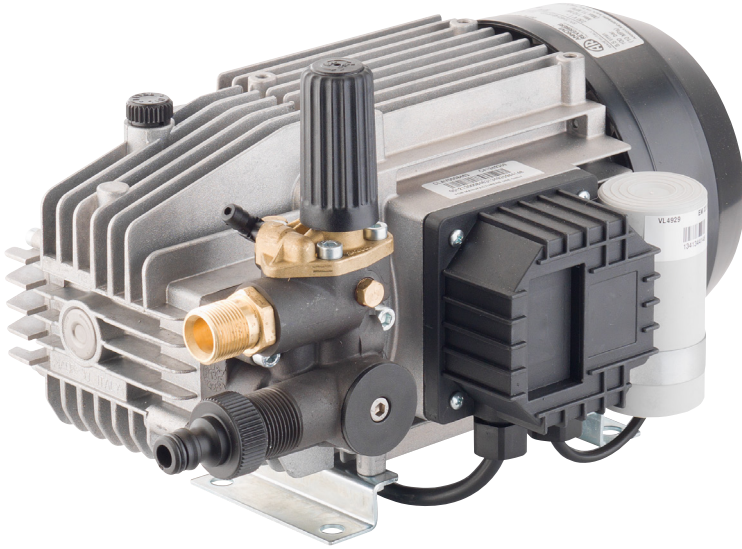

Manometro e interruttore forniti a richiesta.
Pressure gauge and switch on request.

MOD	COD	MAX	MAX							
	1 ~	l/min	gpm	bar	psi	hp	kW	N° giri/1'	V	kg
HPV 2800rpm										
HPV 8.11 EM	20463	8,5	2,25	100	1450	2	1,5	2800	230 ^a	13,8
HPV 11.07 EM	9253	11	2,90	70	1000	1,8	1,3	2800	230 ^a	13,8
HPV 1750rpm										
HPV 2 G15 EM	9256	8	2,11	100	1450	2	1,5	1750	115 ^b	14

a) 1~ 50 Hz
b) 1~ 60 Hz

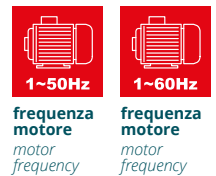



Additional Electric Motor

ELECTRIC MOTOR-PUMP UNITS



idropultrici
pressure
washers

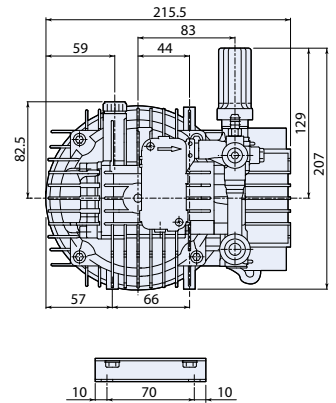
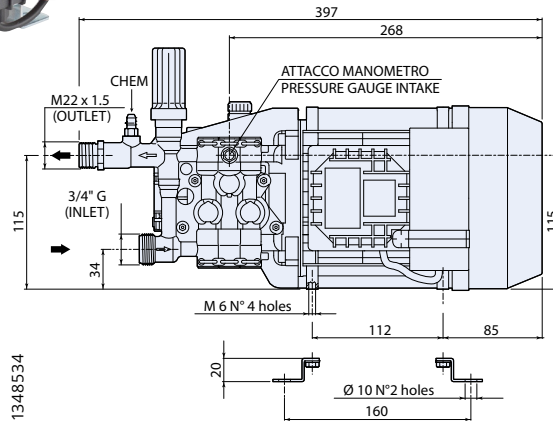
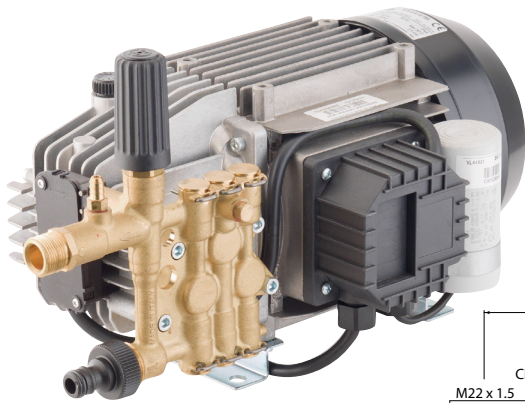

1348534

MOD	COD	MAX	MAX							
	1 ~	l/min	gpm	bar	psi	hp	kW	N° giri/1'	V 1-50Hz	kg
HPV-O 2800rpm										
HPV-O 8.13 TSS EM	23851	8	2,11	130	1900	2,5	2	2800	230	15
HPV-O 8.15 TSS EM	25047	8	2,11	150	2200	3	2,2	2800	230	17
HPV-O 11.09 TSS EM	23906	11	2,90	90	1300	2,5	2	2800	230	15



testa in
ottone
brass
head



frequenza
motore
motor
frequency



ELECTRIC MOTOR-PUMP UNITS



misting

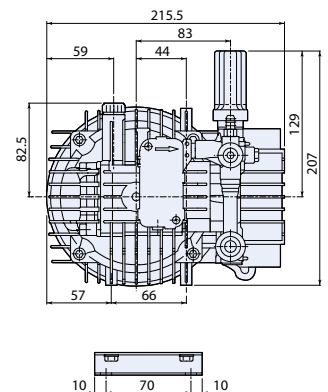
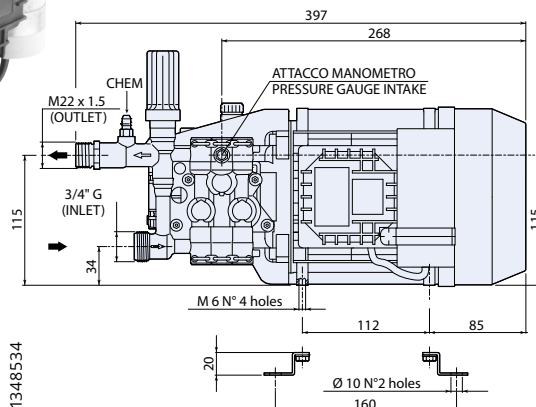
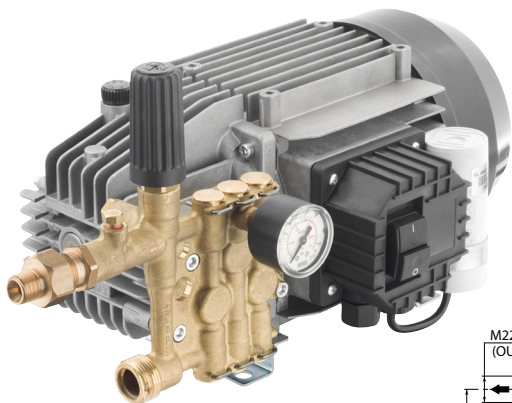

1348534

MOD	COD	MAX	MAX							
	1 ~	l/min	gpm	bar	psi	hp	kW	N° giri/1'	V 1-50Hz	kg
HPV-MO 1450rpm										
HPV-MO 1,3.10 EM	23907	1,3	0,34	100	1450	0,8	0,6	1450	230	14,5



testa in
ottone
brass
head



frequenza
motore
motor
frequency



idropulitrici
pressure
washers



● Model brass head

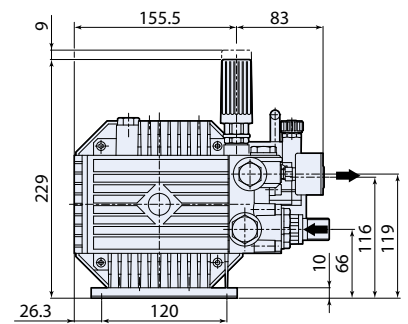
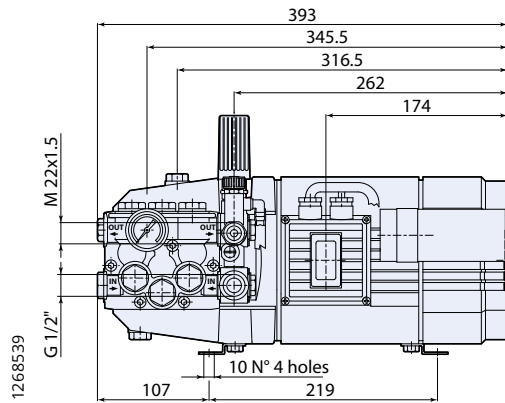

Valvole di regolazione a richiesta.
Regulating valve on request.
Manometro fornito a richiesta.
Pressure gauge on request.

MOD	COD		MAX		MAX						KG NET		
	1~	3~	l/min	gpm	bar	psi	hp	kW	N° giri/1'	V 1-50Hz		V 3-50Hz	
HPE 1450rpm													
HPE 8.12 A EM	8607	-	8	2,11	120	1740	2,5	1,8	1450	230	-	19,2	
HPE 8.12 A ET	-	8608	8	2,11	120	1740	2,5	1,8	1450	-	230/400	19,2	
● HPE 8.14 ET	○	-	8598	8	2,11	140	2000	3	2,2	1450	-	230/400	22,5
HPE 9.11 EM	○	8509	-	9	2,37	110	1600	2,5	1,8	1450	230	-	19,2
HPE 9.11 ET	○	-	8510	9	2,37	110	1600	2,5	1,8	1450	-	230/400	19,2
● HPE 9.14 ET	○	-	8502	9	2,37	140	2000	3	2,2	1450	-	230/400	22,5
HPE 10.10 EM	○	8619	-	10	2,64	100	1450	2,5	1,8	1450	230	-	19,2
HPE 10.10 ET	○	-	8620	10	2,64	100	1450	2,5	1,8	1450	-	230/400	21,5
HPE 10.12 A ET	○	-	8622	10	2,64	120	1740	3	2,2	1450	-	230/400	21,5
HPE 11.09 EM	○	8506	-	11	2,90	90	1300	2,5	1,8	1450	230	-	19,2
HPE 11.09 ET	○	-	8508	11	2,90	90	1300	2,5	1,8	1450	-	230/400	21,5
HPE 11.11 ET	○	-	8552	11	2,90	110	1600	3	2,2	1450	-	230/400	21,5
HPE 13.10 ET	○	-	8548	13	3,43	100	1450	3	2,2	1450	-	230/400	21,5



● testa in
ottone
brass
head



○ bielle in
bronzo
connecting-rods
in bronze



testa in
alluminio
aluminium
head



bielle in
alluminio
connecting-rods
in aluminium



1~50Hz
frequenza
motore
motor
frequency



3~50Hz
frequenza
motore
motor
frequency



Additional Electric Motor

ELECTRIC MOTOR-PUMP UNITS



idropultrici
pressure
washers

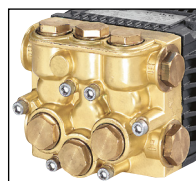

● Model brass head

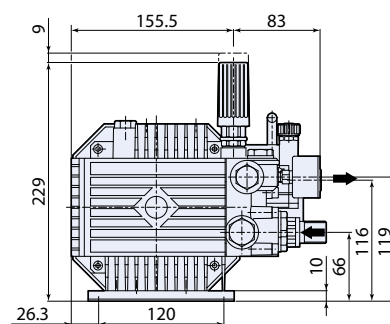
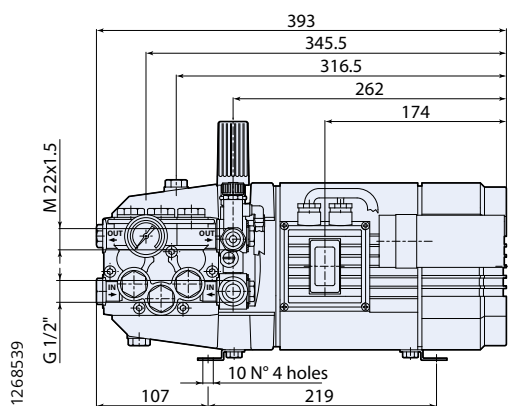

Valvole di regolazione a richiesta.
Regulating valve on request.
Manometro fornito a richiesta.
Pressure gauge on request.

MOD	COD	MAX		MAX		hp	kW	N° giri/1'	V 1-60Hz	KG NET
		l/min	gpm	bar	psi					
HPE 1750 rpm										
HPE 2 G15 EM	8522	8	2,11	100	1450	2	1,5	1750	115	21,5
HPE 2 G15 EM	21849	8	2,11	100	1450	2	1,5	1750	230	21,5
● HPE 2 G18 EM	8525	8	2,11	120	1740	2,5	1,8	1750	230	21,5
HPE 3 G13 EM	● 8534	11,4	3	90	1300	2,5	1,8	1750	230	22
HPE 3.5 G10 EM	8678	13,1	3,5	70	1000	2,5	1,8	1750	230	21,5



● testa in ottone
brass head



○ bielle in bronzo
connecting-rods in bronze



testa in alluminio
aluminium head



bielle in alluminio
connecting-rods in aluminium



1~60Hz
frequenza motore
motor frequency

Additional Electric Motor

ELECTRIC MOTOR-PUMP UNITS







misting

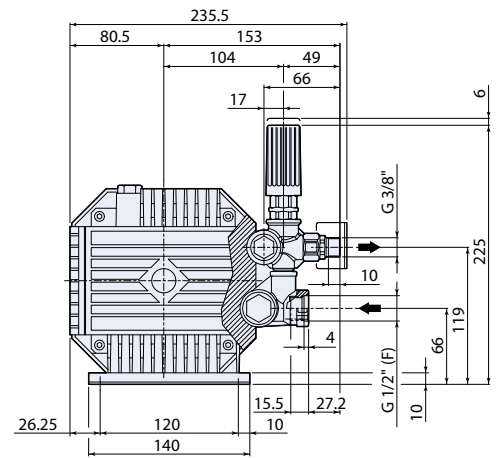
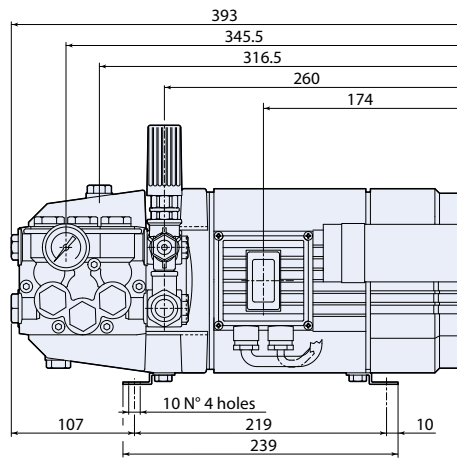

1268544



MOD	COD	 MAX	 MAX							
	1 ~	l/min	gpm	bar	psi	hp	kW	N° giri/1'	V 1-50Hz	kg
HPE-M 1450rpm										
HPE-M 02.08 EM	22096	2	0,52	80	1145	0,5	0,35	1450	230	22
HPE-M 04.08 EM	22097	4	1,06	80	1145	1	0,7	1450	230	22
HPE-M 06.08 EM	22838	6	1,58	80	1145	1	0,7	1450	230	22
HPE-M 08.08 EM	22098	8	2,11	80	1145	1,8	1,35	1450	230	22
HPE-M 11.07 EM	22895	11	2,90	70	1015	2,2	1,65	1450	230	22
HPE-M 13.06 EM	22896	13	3,43	60	870	2,2	1,65	1450	230	22



testa in ottone
brass head



bielle in bronzo
connecting-rods in bronze



1~50Hz
frequenza motore
motor frequency

WOBBLE PLATE

RPV
RPW
RMV
RMW
RQV
RQW

RXV
XJS
SJS
SJV
XJS+F39
HYD-XJS

HRM-O
HRM-MO
HPJ

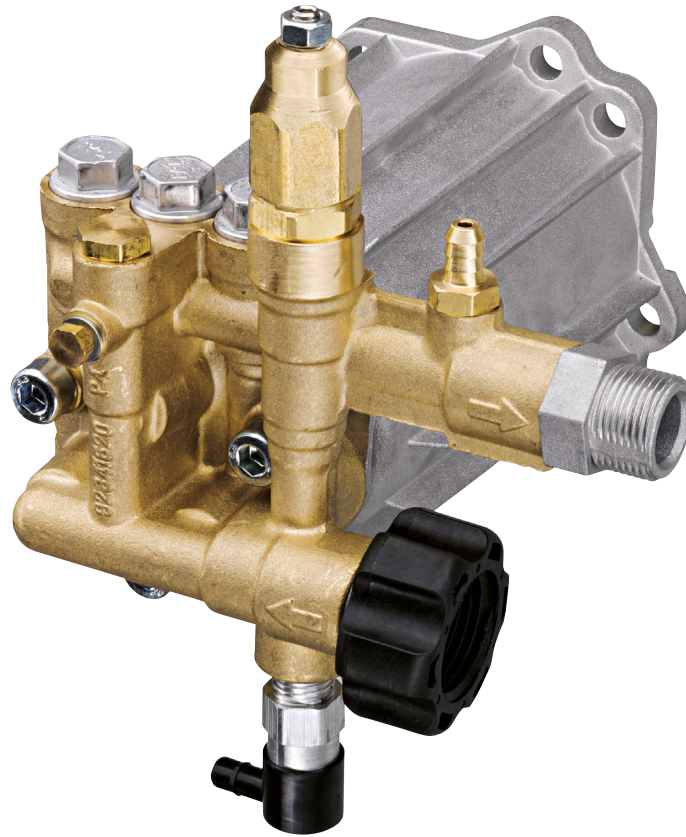

Corpo in lega di alluminio ad alta resistenza.

Pump body in high-strength aluminium alloy.

Piattello oscillante in lega di alluminio con trattamento antiusura.

Wobble plate in aluminium alloy with a special wear-resistant coating.

Testa in ottone o alluminio.

Pump head in brass or aluminium.

Wobble Plate

POMPA ALBERO CAVO Hollow shaft pump

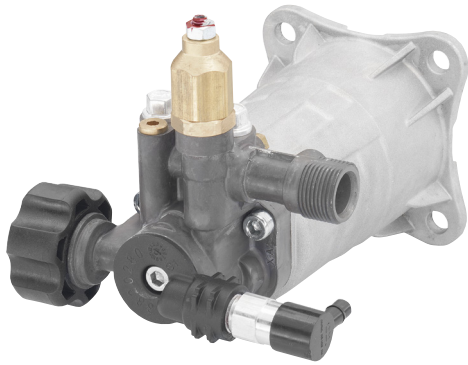

idropultrici
pressure
washers

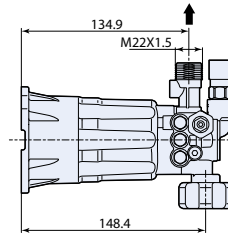
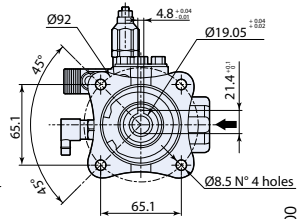
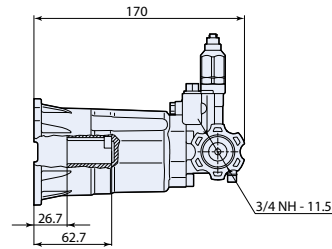
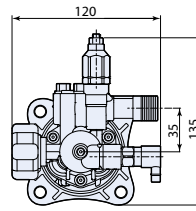

3828500

D version

MOD	COD	MAX	MAX						
		l/min	gpm	bar	psi	hp	kW	N° giri/1'	kg
RPV 3400rpm Dversion Ø 3/4"									
RPV 2 G19 D	24965	7,6	2	130	1900	2,7	2	3400	2,5

Per motori scoppio flangia Ø 3/4" SAE J609a.
For gasoline engine flange Ø 3/4" SAE J609a.



POMPA ALBERO CAVO Hollow shaft pump



idropultrici
pressure
washers

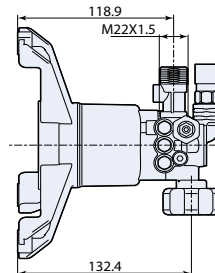
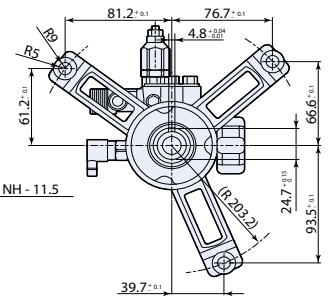
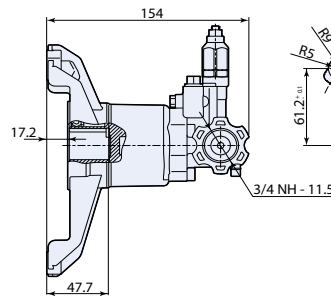
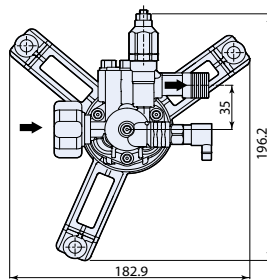

3828501

D version

MOD	COD	MAX	MAX						
		l/min	gpm	bar	psi	hp	kW	N° giri/1'	kg
RPW 3400rpm Dversion Ø 7/8"									
RPW 2 G19 D	24966	7,6	2	130	1900	2,7	2	3400	2,5

Impiego con motori scoppio ad albero verticale.
For direct coupling to vertical engine.



Wobble Plate

POMPA ALBERO CAVO
Hollow shaft pump



idropultrici
pressure
washers

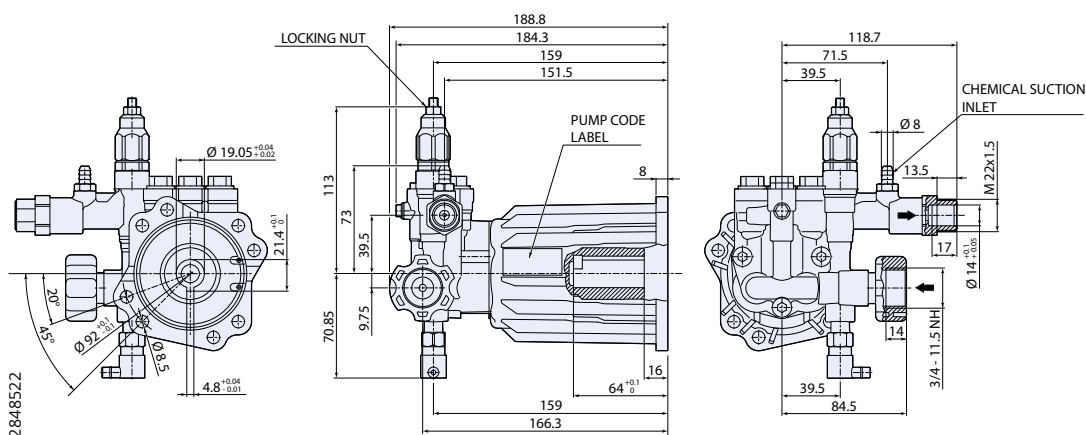
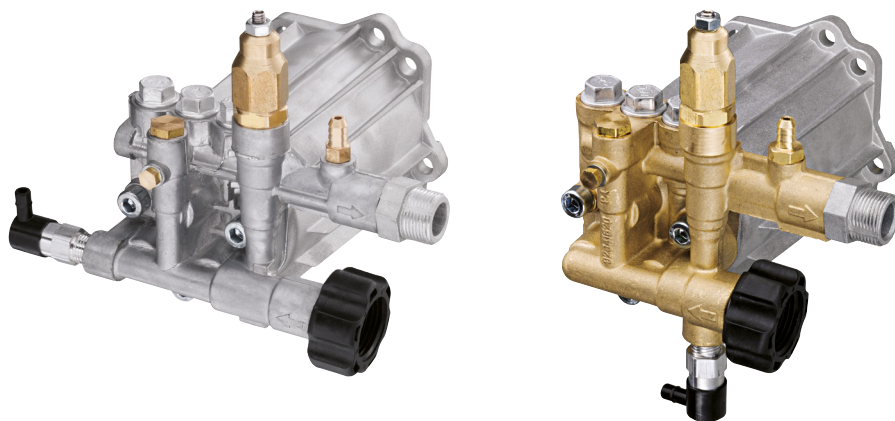

D version

MOD	COD	MAX	MAX						
		l/min	gpm	bar	psi	hp	kW	N° giri/1'	kg
RMV 3400rpm Dversion ϕ 3/4"									
RMV 2 G20 D	25107	7,6	2	140	2000	2,9	2,2	3400	2,5
RMV 2.2 G24 D	24823	8,3	2,2	165	2400	3,8	2,8	3400	2,5
● RMV 2 G23 D	25108	7,6	2	160	2300	3,4	2,5	3400	4
● RMV 2.5 G26 D	25109	9,5	2,5	180	2600	4,8	3,6	3400	4
● RMV 2.5 G30 D	24462	9,5	2,5	205	3000	5,5	4	3400	4

Per motori scoppio flangia ϕ 3/4" SAE J609a.
For gasoline engine flange ϕ 3/4" SAE J609a.



● testa in
ottone
brass
head



● testa in
alluminio
aluminium
head

Wobble Plate

POMPA ALBERO CAVO
Hollow shaft pump



idropultrici
pressure
washers

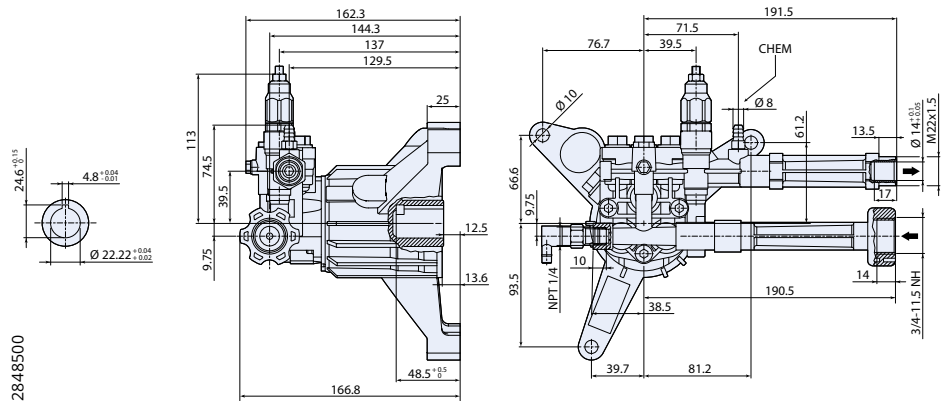
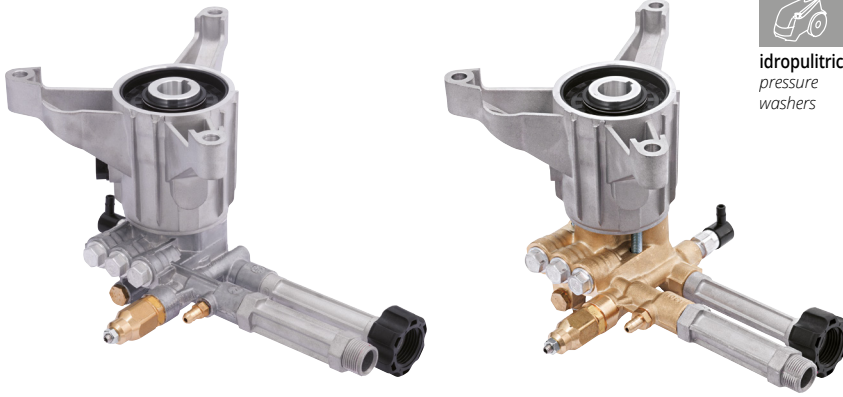

2848500

D version

MOD	COD	MAX	MAX						
		l/min	gpm	bar	psi	hp	kW	N° giri/1'	kg
RMW 3400rpm Dversion Ø 7/8"									
RMW 2 G20 D	25110	7,6	2	140	2000	2,9	2,2	3400	3
RMW 2.2 G24 D	24748	8,3	2,2	165	2400	3,8	2,8	3400	3
● RMW 2 G23 D	25111	7,6	2	160	2300	3,4	2,5	3400	4,5
● RMW 2.5 G26 D	25112	9,5	2,5	180	2600	4,8	3,6	3400	4,5
● RMW 2.5 G28 D	24464	9,5	2,5	190	2800	5,1	3,8	3400	4,5

Impiego con motori scoppio ad albero verticale.
For direct coupling to vertical engine.



● testa in
ottone
brass
head



● testa in
alluminio
aluminium
head



Wobble Plate

POMPA ALBERO CAVO Hollow shaft pump



idropultrici
pressure
washers

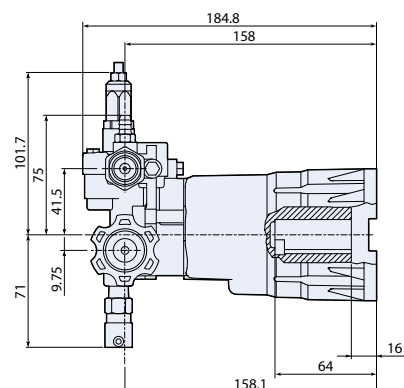
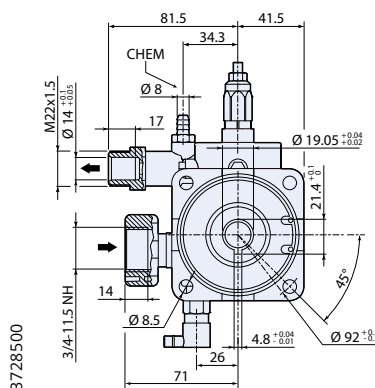
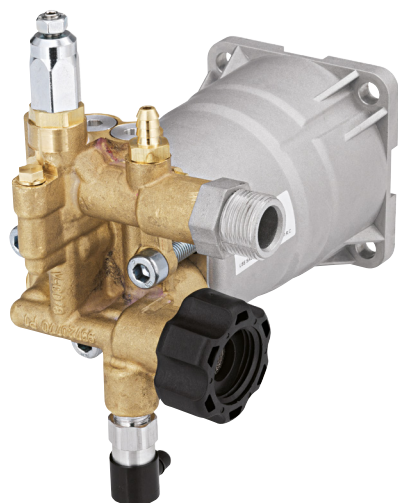

D version

MOD	COD	MAX	MAX						
		l/min	gpm	bar	psi	hp	kW	N° giri/1'	kg



testa in
ottone
brass
head

RQV 3400rpm Dversion Ø 3/4"

RQV 2.5 G30 D **25024** 9,5 2,5 205 3000 5,5 4 3400 3,5

Per motori scoppio flangia Ø 3/4" SAE J609a.
For gasoline engine flange Ø 3/4" SAE J609a.

POMPA ALBERO CAVO Hollow shaft pump



idropultrici
pressure
washers

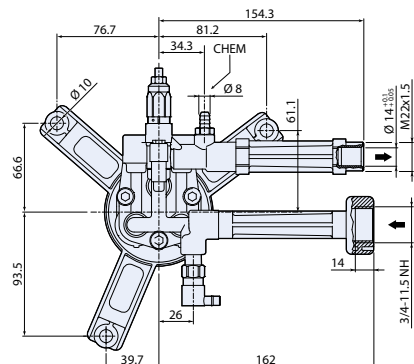
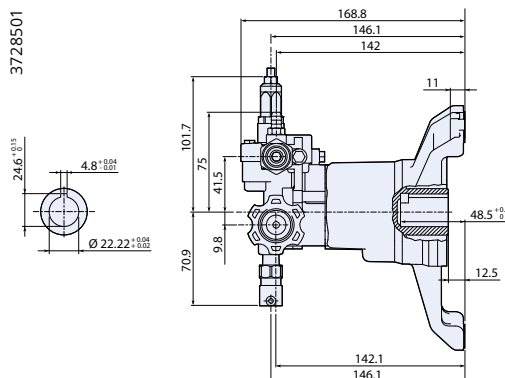
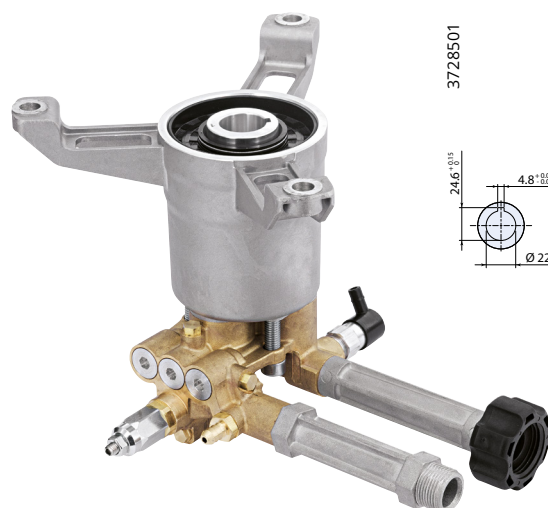

D version

MOD	COD	MAX	MAX						
		l/min	gpm	bar	psi	hp	kW	N° giri/1'	kg



testa in
ottone
brass
head

RQW 3400rpm Dversion Ø 7/8"

RQW 2.5 G28 D **25025** 9,5 2,5 190 2800 5,1 3,8 3400 3,5

Impiego con motori scoppio ad albero verticale.
For direct coupling to vertical engine.

Wobble Plate





POMPA ALBERO CAVO
Hollow shaft pump

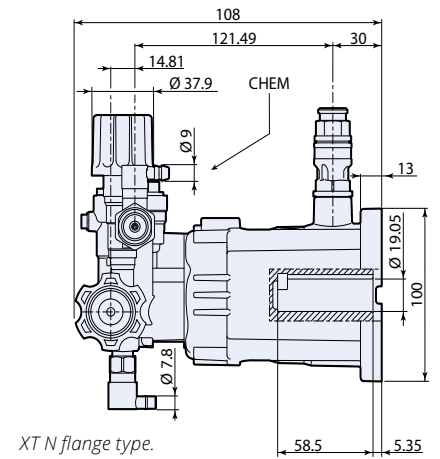
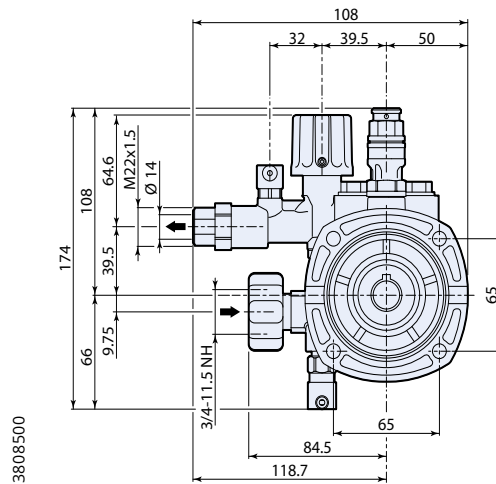
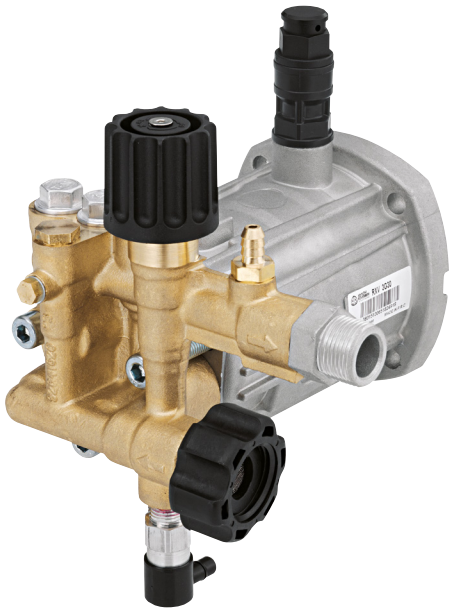

idropultrici
pressure
washers



D version

MOD	COD	 MAX	 MAX						
		l/min	gpm	bar	psi	hp	kW	N° giri/1'	kg
RXV 3400rpm Dversion Ø 3/4"									
RXV 3 G30 D	24918	11,4	3	205	3000	5,5	4	3400	4
RXV 3.5 G30 D	24919	13,2	3,5	205	3000	7	5,2	3400	4

Per motori scoppio flangia Ø 3/4" SAE J609a.
For gasoline engine flange Ø 3/4" SAE J609a.



testa in
ottone
brass
head



Wobble Plate

POMPA ALBERO MASCHIO
Solid shaft pump



idropultrici
pressure
washers

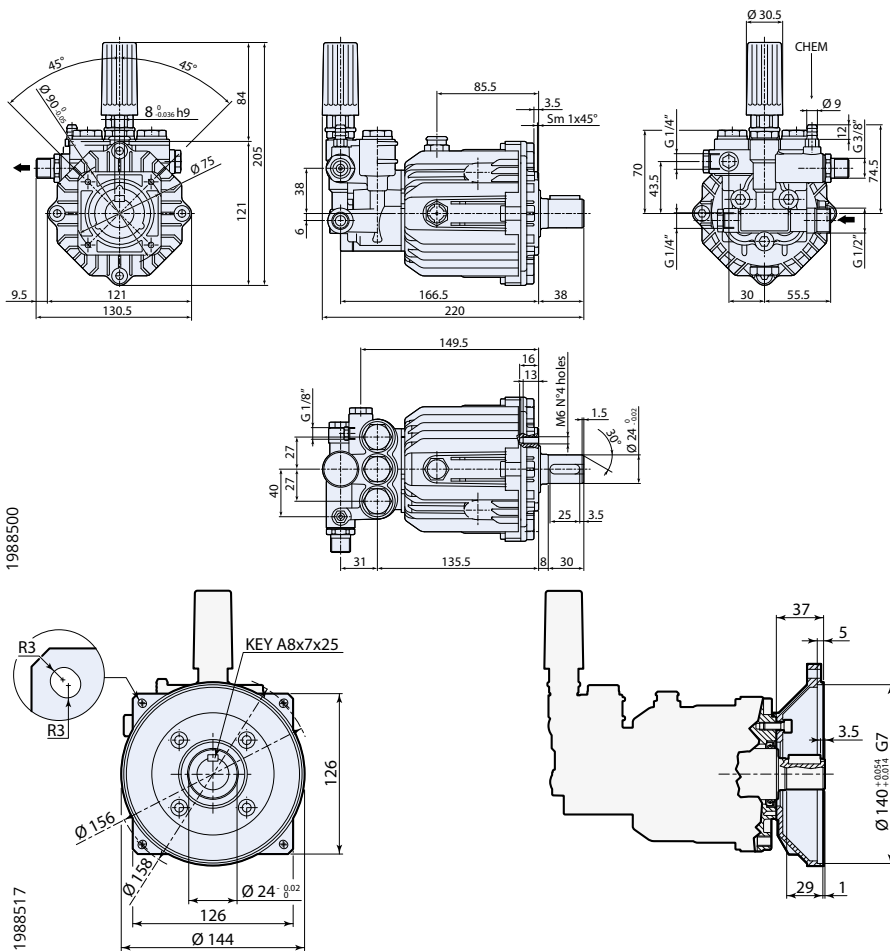
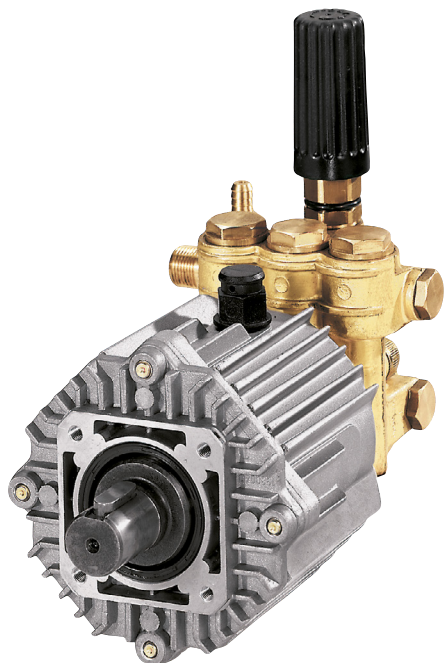

Flangia F9, per motori elettrici speciali AR.
F9 flange for AR special electric motor.

Flangia F9 fornita a richiesta.
F9 flange on request.

N version

MOD	COD	MAX	MAX						
		l/min	gpm	bar	psi	hp	kW	N° giri/1'	kg
XJS 2800rpm Nversion $\varnothing 24$ mm									
XJS 8.15 N	20327	8	2,11	150	2200	3	2,2	2800	5
XJS 10.15 N	20329	10	2,64	150	2200	4	3	2800	5
XJS 11.14 N	20332	11	2,90	140	2000	4	3	2800	5
SJS 2800rpm Nversion $\varnothing 24$ mm									
SJS 8.17 N	20835	8	2,11	170	2500	3,5	2,6	2800	5
SJS 10.17 N	20836	10	2,64	170	2500	4,5	3,3	2800	5
SJS 11.17 N	20837	11	2,90	170	2500	5	3,5	2800	5



testa in
ottone
brass
head

Flangiatura compatibile XT N.
XT N flange type.

Wobble Plate

POMPA ALBERO CAVO Hollow shaft pump



idropultrici
pressure
washers

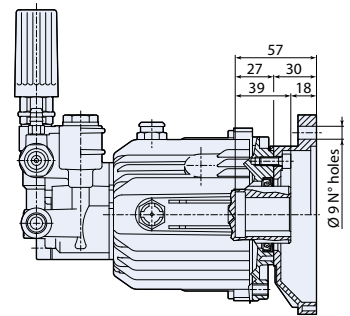
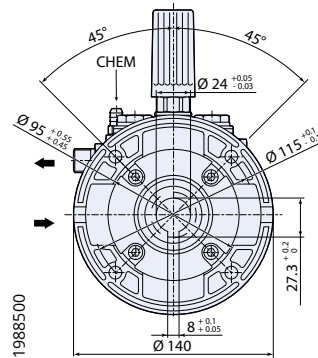

Flangia F6 fornita a richiesta.
F6 flange on request.

C version

MOD	COD	MAX	MAX					
		l/min	gpm	bar	psi	hp	kW	N° giri/1'
XJS 2800rpm Cversion Ø 24mm								
XJS 8.15 C	20484	8	2,11	150	2200	3	2,2	2800
XJS 10.15 C	20441	10	2,64	150	2200	4	3	2800
XJS 11.14 C	20442	11	2,90	140	2000	4	3	2800

Flangia F6, per motori elettrici B14 Gr.90 IEC34-7, 2 poli 50Hz. Flangia non inclusa.
F6 flange for electric motor B14 90 IEC34-7, 2 poles 50Hz. Flange not included.



testa in
ottone
brass
head



POMPA ALBERO CAVO Hollow shaft pump



idropultrici
pressure
washers

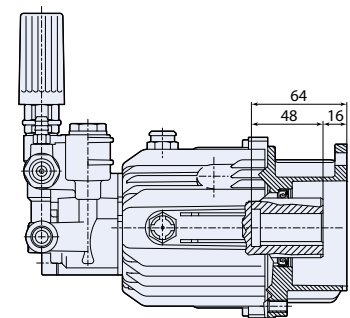
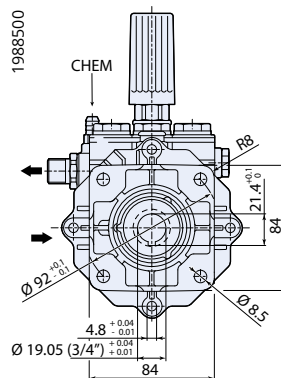

D version + F7

MOD	COD	MAX	MAX					
		l/min	gpm	bar	psi	hp	kW	N° giri/1'
SVJ 3400rpm Dversion + F7 Ø 3/4"								
SVJ 2 G25 D + F7	21663	7,6	2	170	2500	3,5	2,6	3400
SVJ 2.5 G25 D + F7	21664	9,5	2,5	170	2500	4,5	3,3	3400
SVJ 3 G27 D + F7	21666	11,4	3	186	2700	5,5	4	3400
SVJ 3.5 G25 D + F7	21667	13,2	3,5	170	2500	6	4,4	3400

Per motori scoppio flangia Ø 3/4" SAE J609a. Flangia inclusa.
For gasoline engine flange Ø 3/4" SAE J609a. Flange included.



testa in
ottone
brass
head



Wobble Plate

ELECTRIC MOTOR-PUMP UNITS



idropultrici
pressure
washers

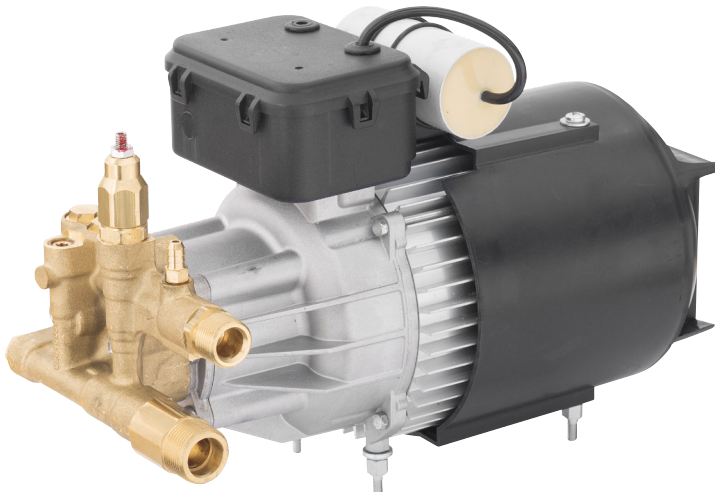

HRM-O 6.12

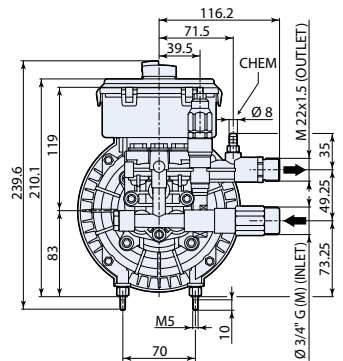
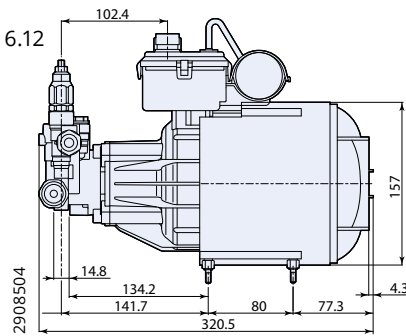

HRM-O 9.15

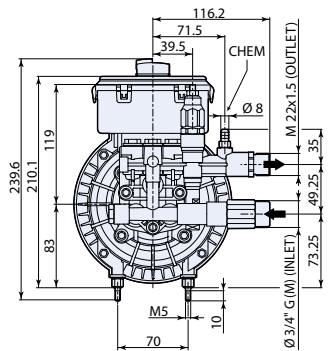
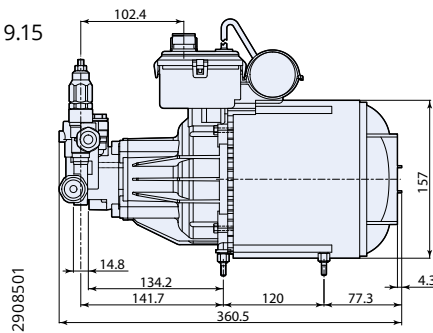

MOD	COD	MAX	MAX							
	1 ~	l/min	gpm	bar	psi	hp	kW	N° giri/1'	V 1-50Hz	kg
HRM-O 2800rpm										
HRM-O 6.12 REG EM	23006	5,5	1,46	115	1700	1,6	1,2	2800	230	15,5
HRM-O 9.15 REG EM	22119	9	2,5	150	2200	3,15	2,3	2800	230	16
HRM-O 9.15 TSS EM	22296	9	2,5	150	2200	3,15	2,3	2800	230	16

Disponibile anche versioni 60 Hz, previa verifica tecnica.
60 Hz versions available upon technical verification.



testa in
ottone
brass
head



frequenza
motore
motor
frequency







Wobble Plate

ELECTRIC MOTOR-PUMP UNITS

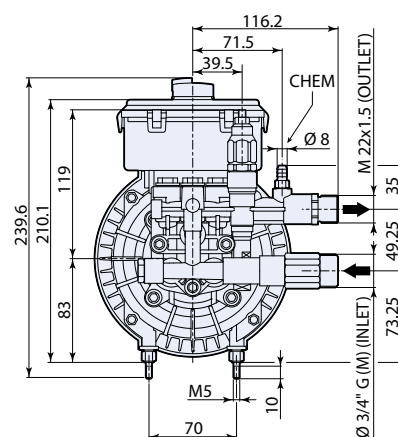
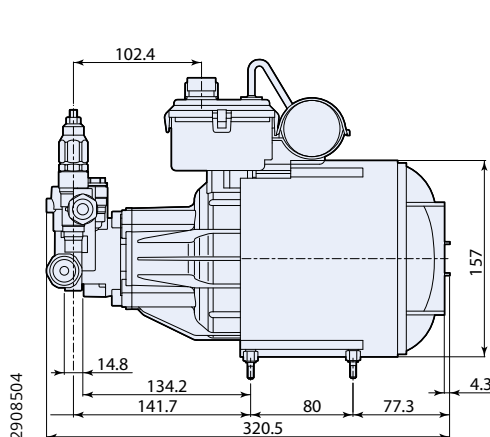
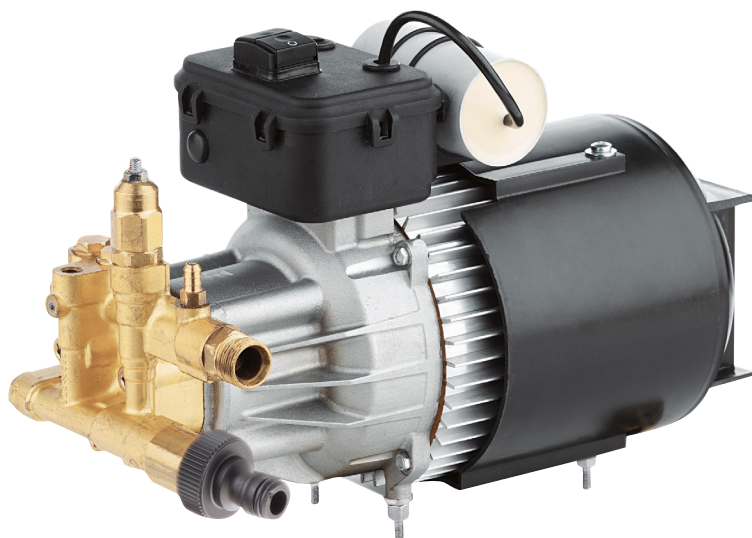

misting



MOD	COD	 MAX	 MAX							
	1 ~	l/min	gpm	bar	psi	hp	kW	N° giri/1'	V 1-50Hz	kg
HRM-MO 1450rpm										
HRM-MO 0,5.08 EM	24753	0,5	0,13	80	1145	0,15	0,1	1450	230	15
HRM-MO 01.08 EM	22627	1	0,26	80	1145	0,3	0,2	1450	230	15,5
HRM-MO 02.08 EM	22628	2	0,52	80	1145	0,5	0,4	1450	230	15,5
HRM-MO 04.08 EM	22629	4	1,06	80	1145	1	0,8	1450	230	15,5

Disponibile anche la versione 115 Volt / 60 Hz.
115 Volt / 60 Hz version available.



testa in
ottone
brass
head



frequenza
motore
motor
frequency



Wobble Plate

ELECTRIC MOTOR-PUMP UNITS



idropultrici
pressure
washers



T SS/REG model

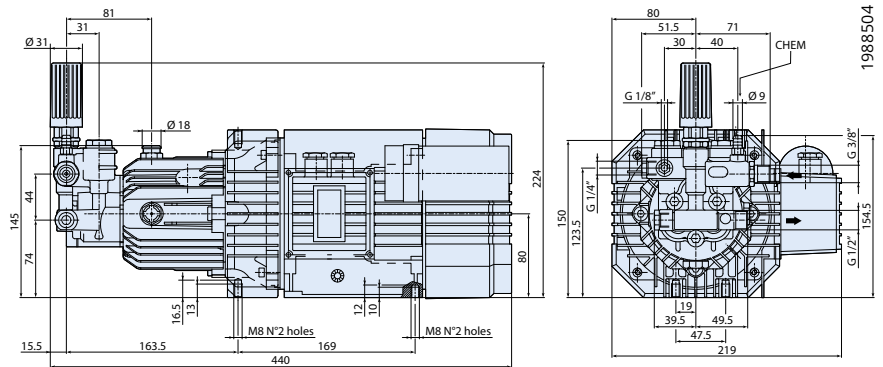

MOD	COD		MAX		MAX		V		kg			
	1~	3~	l/min	gpm	bar	psi	hp	kW				
HPJ 2800rpm												
HPJ 8.12 REG EM	20415	-	8	2,11	120	1740	2,5	1,8	2800	230	-	20,4
HPJ 8.12 TSS/REG EM	20994	-	8	2,11	120	1740	2,5	1,8	2800	230	-	20,4
HPJ 8.15 REG EM	20416	-	8	2,11	150	2200	3	2,2	2800	230	-	21
HPJ 8.15 TSS/REG EM	20995	-	8	2,11	150	2200	3	2,2	2800	230	-	21
HPJ 10.12 REG EM	20417	-	10	2,64	120	1740	3	2,2	2800	230	-	21
HPJ 10.12 TSS/REG EM	20996	-	10	2,64	120	1740	3	2,2	2800	230	-	21
HPJ 10.15 REG ET	-	20418	10	2,64	150	2200	4	3	2800	-	380	21,3
HPJ 10.15 TSS/REG ET	-	21073	10	2,64	150	2200	4	3	2800	-	380	21,3
HPJ 11.11 REG EM	20419	-	11	2,90	110	1600	3	2,2	2800	230	-	21
HPJ 11.11 TSS/REG EM	20997	-	11	2,90	120	1740	3	2,2	2800	230	-	21
HPJ 11.14 REG ET	-	20420	11	2,90	140	2000	4	3	2800	-	380	21,3

Disponibili anche le versione 60 Hz, previa verifica tecnica.
60 Hz versions available upon technical verification.



testa in
ottone
brass
head



1~50Hz
frequenza
motore
motor
frequency



3~50Hz
frequenza
motore
motor
frequency

Wobble Plate

HYDRAULIC DRIVE



municipality

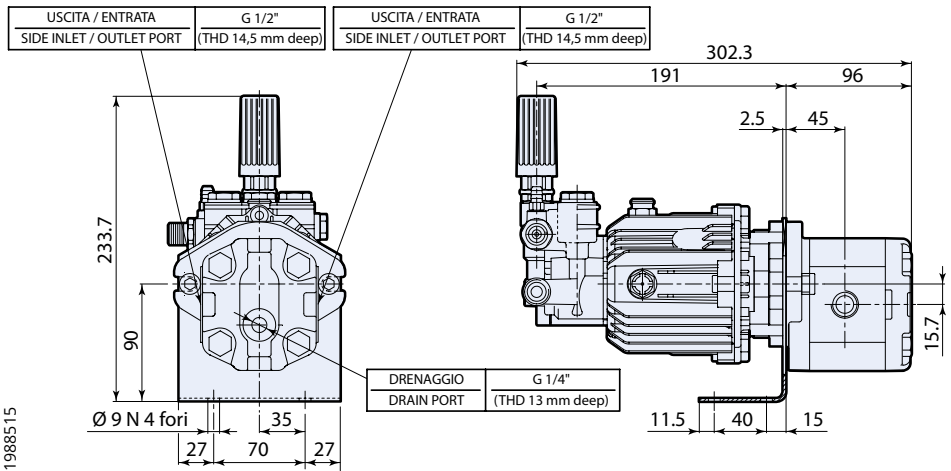

1988515



testa in ottone
brass head



motore idraulico
hydraulic drive

HYD - XJS

MOD	COD	POMPA A PISTONI • HP PISTON PUMP				MOTORE IDRAULICO • HYDRAULIC MOTOR				KG NET				
		MAX	MAX	RPM	⚡	MAX	MAX	RPM						
		l/min	gpm	bar	psi	N° giri/1'	hp	Type	Cod	cm ³	bar	l/min	N° giri/1'	kg
HYD-XJS														
HYD XJS 11.14	21602	11	2,90	140	2030	2800	4	SNM2NN/8,0BN06 GAM1F4F4N	4768	8,4	123	24,5	2800	5

HYDRAULIC DRIVE



municipality

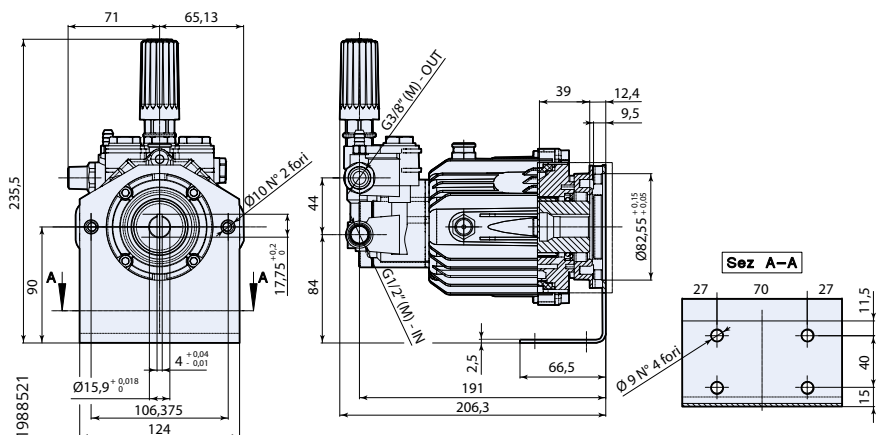

XJS + F39

MOD	COD	MAX	MAX	⚡	KG NET			N° giri/1'	kg
		l/min	gpm			bar	psi		
XJS 2800rpm + F39									
XJS 11.14 + F39	21597	11	2,90	140	2030	4	3	2800	3



testa in ottone
brass head

ACCESSORI

Accessories

Valvole di Regolazione

(Regulation Valves)

VRZ TSS + ID



Valvola di regolazione con ritorno automatico della pompa a 0 bar alla chiusura, by-pass con sistema di arresto totale a distanza.

Pressure regulating unloader valve, automatically relieves pressure from pump at shut-off, built-in by-pass and remote control for total shutdown.

INLET: 1/2" G (F), OUTLET: 3/8" G (M)

For RC, XM, RK series

COD.24324

Max 200 bar, 15 l/min

TSS®
Total Stop
SYSTEM

VRZ + ID, IDR

Valvola di regolazione con ritorno automatico della pompa a 0 bar alla chiusura, by-pass.

Pressure regulating unloader valve, automatically relieves pressure from pump at shut-off, built-in by-pass.

INLET: 1/2" G (F), OUTLET: 3/8" G (M)

For RC, XM, RK series

COD.24669

Max 250 bar, 21 l/min



Con iniettore detergente.
With detergent injector.

COD.24591

Max 250 bar, 8÷15 l/min

COD.24670

Max 250 bar, 15,1÷21 l/min



Con iniettore detergente regolabile.
With adjustable detergent injector.

COD.24671

Max 250 bar, 8÷15 l/min

COD.24672

Max 250 bar, 15,1÷21 l/min



VRC-A

Valvola di regolazione con ritorno automatico della pompa a 0 bar alla chiusura.

Pressure regulating unloader valve, automatically relieves pressure from pump at shut-off.

For RC series

COD.23500

Max 180 bar, 18 l/min

INLET: 3/8" G (F), OUTLET: 3/8" G (M)

BY-PASS: 3/8" G (F)

For RC series

Con iniettore detergente

With detergent injector

COD.23501

Max 180 bar, ID, 15 l/min (*)

INLET: 3/8" G (F), OUTLET: 3/8" G (M)

BY-PASS: 3/8" G (F)



VRC-AM

Valvola di regolazione con ritorno automatico della pompa a 0 bar alla chiusura.

Pressure regulating unloader valve, automatically relieves pressure from pump at shut-off.

For RC series

COD.23502

Max 180 bar, 18 l/min

INLET: 3/8" G (F), OUTLET: 3/8" G (M)

BY-PASS: 3/8" G (F)



For RC series

Con iniettore detergente.

With detergent injector.

COD.23503

Max 180 bar, ID, 15 l/min (*)

INLET: 3/8" G (F), OUTLET: 3/8" G (M)

BY-PASS: 3/8" G (F)

* Su richiesta versione 18 l/min

On request 18 l/min version



VRC-BM

Valvola di regolazione con ritorno automatico della pompa a 0 bar alla chiusura.

Pressure regulating unloader valve, automatically relieves pressure from pump at shut-off.

For XT, RC, XM, RR

Con iniettore detergente.

With detergent injector.

COD.23505

Max 180 bar, 15 l/min (*)

INLET: 3/8" G (F), OUTLET: 3/8" G (M)

For XT, RC, XM, RR

Con iniettore detergente regolabile.

With adjustable detergent injector.

COD.23506

Max 180 bar, IDR, 15 l/min (*)

INLET: 3/8" G (F), OUTLET: 3/8" G (M)

* Su richiesta versione 18 l/min

On request 18 l/min version



MINI MATIC 4/B, + ID, IDR

Valvola di regolazione con ritorno automatico della pompa a 0 bar alla chiusura, by-pass.

Pressure regulating unloader valve, automatically relieves pressure from pump at shut-off, built-in by-pass.

INLET: 1/2" G (F), OUTLET: 3/8" G (M)

For HPE, XT, RC, XM, RR, RK series

COD.20821

Max 180 bar, 18 l/min



Con iniettore detergente

With detergent injector

COD.20888

Max 180 bar, 7÷10 l/min (Ø2,0)

COD.20889

Max 180 bar, 10,1÷18 l/min (Ø2,3)



Con iniettore detergente regolabile.

With adjustable detergent injector.

COD.20890

Max 180 bar, 7÷10 l/min (Ø2,0)

COD.20891

Max 180 bar, 10,1÷18 l/min (Ø2,3)



MINI MATIC 4/B TSS, + ID, IDR

TSS®
Total Stop
SYSTEM

Valvola di regolazione con ritorno automatico della pompa a 0 bar alla chiusura, by-pass con sistema di arresto totale a distanza (patented).

Pressure regulating unloader valve, automatically relieves pressure from pump at shut-off, built-in by-pass and remote control for total shutdown (patented).

INLET: 1/2" G (F), OUTLET: 3/8" G (M)

For XT, RC, XM, RR, RK

COD. 25395

Max 180 bar, 18 l/min



For XT, XM, RR, RK

Con iniettore detergente con sistema di arresto totale a distanza (patented).
With detergent injector and remote control for total shutdown (patented).

COD. 25396

Max 180 bar, 7÷10 l/min (Ø2,0)

COD. 25397

Max 180 bar, 10,1÷18 l/min (Ø2,3)



For XT, XM, RR, RK

Con iniettore detergente regolabile con sistema di arresto totale a distanza (patented).
With adjustable detergent injector and remote control for total shutdown (patented).

With adjustable detergent injector and remote control for total shutdown (patented).

COD. 22562

Max 180 bar, 7÷10 l/min (Ø2,0)

COD. 25398

Max 180 bar, 10,1÷18 l/min (Ø2,3)



Valvole di Regolazione

(Regulation Valves)

GYMATIC 3/A, + ID, IDR

Valvola di regolazione con ritorno automatico della pompa a 0 bar alla chiusura.

Pressure regulating unloader valve, automatically relieves pressure from pump at shut-off.

INLET, OUTLET, BY-PASS: 3/8" G (M)

For XM, RR, JK, RK, RW series

COD.20076

Max 250 bar, 35 l/min

Con iniettore detergente.

With detergent injector.

COD.20077

Max 250 bar, 11 l/min (Ø1,8)

COD.20078

Max 250 bar, 13÷18 l/min (Ø2,1)

COD.20079

Max 250 bar, 21 l/min (Ø2,3)

Con iniettore detergente regolabile.

With adjustable detergent injector.

COD.20396

Max 250 bar, 11 l/min (Ø1,8)

COD.20397

Max 250 bar, 13÷18 l/min (Ø2,1)

COD.20398

Max 250 bar, 21 l/min (Ø2,3)

GYMATIC 3/A 'C'

Valvola di regolazione con ritorno automatico della pompa a 0 bar alla chiusura.

Pressure regulating unloader valve, automatically relieves pressure from pump at shut-off.

For XM, RR, JK, RK, RW series

COD.21828

Max 250 bar, 35 l/min

INLET, OUTLET, BY-PASS: 3/8" G (M)

GYMATIC 3/B, + ID, IDR

Valvola di regolazione con ritorno automatico della pompa a 0 bar alla chiusura, by-pass.

Pressure regulating unloader valve, automatically relieves pressure from pump at shut-off, built-in by-pass.

INLET: 1/2" G (F), OUTLET: 3/8" G (M)

For XM, RR, JK, RK series

COD.20080

Max 250 bar, 35 l/min

For JK, RK series

Con iniettore detergente.

With detergent injector.

COD.20081

Max 250 bar, 11 l/min (Ø1,8)

COD.20082

Max 250 bar, 13÷18 l/min (Ø2,1)

COD.20083

Max 250 bar, 21 l/min (Ø2,3)

Con iniettore detergente regolabile.

With adjustable detergent injector.

COD.20399

Max 250 bar, 11 l/min (Ø1,8)

COD.20400

Max 250 bar, 13÷18 l/min (Ø2,1)

COD.20401

Max 250 bar, 21 l/min (Ø2,3)

GYMATIC 3/B, + ID, IDR for XW

Valvola di regolazione con ritorno automatico della pompa a 0 bar alla chiusura, by-pass.

Pressure regulating unloader valve, automatically relieves pressure from pump at shut-off, built-in by-pass.

INLET: 3/4" G (F), OUTLET: 3/8" G (M)

For XW series

COD.20802

Max 250 bar, 35 l/min

For XW series

Con iniettore detergente.

With detergent injector.

COD.20759

Max 250 bar, 13÷18 l/min (Ø2,1)

COD.20760

Max 250 bar, 21 l/min (Ø2,3)

For XW series

Con iniettore detergente regolabile.

With adjustable detergent injector.

COD.20761

Max 250 bar, 13÷18 l/min (Ø2,1)

COD.20762

Max 250 bar, 21 l/min (Ø2,3)

VR 35

Valvola di regolazione con ritorno automatico della pompa a 0 bar alla chiusura.

Pressure regulating unloader valve, automatically relieves pressure from pump at shut-off.

INLET: 3/8" G (F), OUTLET: 3/8" G (M),
BY-PASS: 3/8" G (F)

COD. 20831

Max 350 bar, 35 l/min

VR 35/C

Valvola di regolazione con ritorno automatico della pompa a 0 bar alla chiusura.

Pressure regulating unloader valve, automatically relieves pressure from pump at shut-off.

INLET: 3/8" G (F), OUTLET: 3/8" G (M),
BY-PASS: 3/8" G (F)

COD. 21827

Max 350 bar, 45 l/min

VR SS

Valvola di regolazione con corpo in acciaio e ritorno automatico della pompa a 0 bar alla chiusura.

Pressure regulating unloader valve with steel body, automatically relieves pressure from pump at shut-off.

INLET: 3/8" G (F), OUTLET: 3/8" G (M),
BY-PASS: 3/8" G (F)

For Stainless Steel series

COD. 21350

Max 200 bar, 45 l/min

VR 3B for RK series

Valvola di regolazione con ritorno automatico della pompa a 0 bar alla chiusura, by-pass.

Pressure regulating unloader valve, automatically relieves pressure from pump at shut-off, built-in by-pass.

INLET: 1/2" G (F), OUTLET: 3/8" G (M)

For RK series

COD. 22308

Max 300 bar, 35 l/min

VR 3B for RG, RW series + ID, IDR

Valvola di regolazione con ritorno automatico della pompa a 0 bar alla chiusura, by-pass.

Pressure regulating unloader valve, automatically relieves pressure from pump at shut-off, built-in by-pass.

For RG, RW series

COD. 22621

Max 300 bar, 35 l/min

COD. 22622

Max 250 bar ID, 13-18 l/min, D 2,1

COD. 22623

Max 250 bar ID, 18-21 l/min, D 2,3

COD. 22624

Max 250 bar IDR, 13-18 l/min, D 2,1

COD. 22625

Max 250 bar IDR, 18-21 l/min, D 2,3

INLET: 1/2" G (F), OUTLET: 3/8" G (M)

VR 3B for XW series

Valvola di regolazione con ritorno automatico della pompa a 0 bar alla chiusura, by-pass.

Pressure regulating unloader valve, automatically relieves pressure from pump at shut-off, built-in by-pass.

For XW series

COD. 21839

Max 300 bar, 35 l/min

INLET: 1/2" G (F), OUTLET: 3/8" G (M)

COD. 21840

Max 300 bar, 35 l/min

INLET: 3/4" G (F), OUTLET: 3/8" G (M)

ZEROMATIC/93

Valvola di regolazione con ritorno automatico della pompa a 0 bar alla chiusura.

Pressure regulating unloader valve, automatically relieves pressure from pump at shut-off.

COD. 2907

Max 250 bar, 40 l/min

INLET: 1/2" G (F), OUTLET: 3/8" G (M),

BY-PASS: 1/2" G (F)

COD. 2908

Max 250 bar, 40 l/min

INLET: 1/2" NPT (F),

OUTLET: 3/8" NPT (M),

BY-PASS: 1/2" NPT (F)

ZEROMATIC/CSC

COD. 22789

Max 250 bar, 40 l/min

INLET: 1/2" G (F), OUTLET: 3/8" G (M),

BY-PASS: 1/2" G (F)

Per controllo statico circuiti idraulici.

For hydraulic circuit static check.



Valvole di Regolazione (Regulation Valves)

VB 85/280



Valvola di regolazione con ritorno automatico della pompa a 0 bar alla chiusura.
Pressure regulating unloader valve, automatically relieves pressure from pump at shut-off.

INLET: 1/2" G (F), OUTLET: 1/2" G (F), BY-PASS: 1/2" G (F)

For RTX 70.200 - RTX 85.150
RTJ 70.275

COD. 51435

Max 280 bar, 80 l/min

VS 310



Valvola di sicurezza. Valvola compensata regolatrice di pressione. Regolarizza il bypass del fluido, con una minima variazione della pressione.
Safety valve. Compensated pressure regulating valve.

Regulates the bypass of the fluid with a minimum variation of the pressure.

INLET: 3/8" G (F), OUTLET: 3/8" G (F)

COD. 51480

Max 310 bar, 40 l/min

VS 200/180



Valvola di sicurezza. Valvola compensata regolatrice di pressione. Regolarizza il bypass del fluido, con una minima variazione della pressione.
Safety valve. Compensated pressure regulating valve.

Regulates the bypass of the fluid with a minimum variation of the pressure.

INLET: 3/4" G (F), OUTLET: 1/2" G (F),

COD. 51437

Max 180 bar, 200 l/min

VB 350



Valvola di regolazione con ritorno automatico della pompa a 0 bar alla chiusura, by-pass.
Pressure regulating unloader valve, automatically relieves pressure from pump at shut-off, built-in by-pass.

INLET: 3/8" G (M), OUTLET: 3/8" G (F), BY-PASS: 1/2" G (F)

For RTX 30.300

COD. 50687

Max 350 bar, 40 l/min

VB 53



Valvola di regolazione con ritorno automatico della pompa a 0 bar alla chiusura, by-pass.
Pressure regulating unloader valve, automatically relieves pressure from pump at shut-off, built-in by-pass.

INLET: 1/2" G (F), OUTLET: 1/2" G (F), BY-PASS: 1/2" G (F)

For RTX 50.300 - RTX 60.300
RTX 30.500 RTP 30.500
RTP 38.500

COD. 40790

Max 500 bar, 80 l/min



VB 140/160

Valvola di regolazione con ritorno automatico della pompa a 0 bar alla chiusura, by-pass.
Pressure regulating unloader valve, automatically relieves pressure from pump at shut-off, built-in by-pass.

INLET: 3/4" G (F), OUTLET: 3/4" G (F), BY-PASS: 3/4" G (F)

For RTX 100.120
RTF 135.100 - RTF 150.100
RTD 130.100 - RTD 130.160

COD. 51839

Max 160 bar, 140 l/min

VB 200/280



Valvola di regolazione con ritorno automatico della pompa a 0 bar alla chiusura.
Pressure regulating unloader valve, automatically relieves pressure from pump at shut-off.

INLET: 1" G (F), OUTLET: 1" G (F), BY-PASS: 1" G (F)

For RTD 100.200

COD. 51636

Max 280 bar, 200 l/min

VB 60/600



Valvola di regolazione con ritorno automatico della pompa a 0 bar alla chiusura.
Pressure regulating unloader valve, automatically relieves pressure from pump at shut-off.

INLET: 1/2" G (F), OUTLET: 1/2" G (F) BY-PASS: 1/2" G (F)

For RTP 30.600

COD. 51179

Max 600 bar, 60 l/min

NEW

VRPP 170



Valvola di regolazione con ritorno automatico della pompa a 0 bar alla chiusura.
Pressure regulating unloader valve, automatically relieves pressure from pump at shut-off.

INLET: 1" G (F), OUTLET: 1" G (F) BY-PASS: 1" G (F)

For RTD 160.100, RTD 160.130, RTX 150.100

COD. 51859

Max 150 bar, 200 l/min

NEW

VB 200/150



Valvola di regolazione con ritorno automatico della pompa a 0 bar alla chiusura.
Pressure regulating unloader valve, automatically relieves pressure from pump at shut-off.

INLET: 1" G (F), OUTLET: 1" G (F) BY-PASS: 1" G (F)

For RTD 160.100, RTD 160.130, RTX 150.100

COD. 50160

Max 150 bar, 200 l/min

Riduttori (Gear Boxes)

CR 3/4"



Riduttore 1:2 per motori a scoppio/diesel con albero cilindrico 3/4" (19,05 mm) e flangia SAE J609a.
1:2 reduction gear box for gas/diesel engines with 3/4" cylindrical shaft and SAE J609a flange.

XT series
COD.1694

XM, RK series
COD.1692

Riduttore 1:2,24 per motori a scoppio/diesel con albero cilindrico 3/4" (19,05 mm) e flangia SAE J609a.
1:2,24 reduction gear box for gas/diesel engines with 3/4" cylindrical shaft and SAE J609a flange.

XM, RK series
COD.1691

CR 1"



Riduttore 1:2 per motori a scoppio/diesel con albero cilindrico 1" (25,4 mm) e flangia SAE J609a.
1:2 reduction gear box for gas/diesel engines with 1" cylindrical shaft and SAE J609a flange.

XT series
COD.1693

XM, RK series
COD.1690

RG, RW, XW, SXW series
COD.1697

Riduttore 1:2,24 per motori a scoppio/diesel con albero cilindrico 1" (25,4 mm) e flangia SAE J609a.
1:2,24 reduction gear box for gas/diesel engines with 1" cylindrical shaft and SAE J609a flange.

XM, RK series
COD.1689

RG, RW, XW, SXW series
COD.1698

CR 1"1/8



Riduttore 1:2 per motori a scoppio/diesel con albero cilindrico 1" 1/8 (28,6 mm) e flangia SAE J609a.
1:2 reduction gear box for gas/diesel engines with 1" 1/8 cylindrical shaft and SAE J609a flange.

RG, RW, XW, SXW series
COD.1670



Accessori

accessories

Lance

(Lances)

RE 70 • RE 90 • RE 120 • RE 150 • RE 170 • RE 200

Lancia. Lunghezza: • Lance. Length:

70 cm max 250 bar 40 l/min, 180° C.
INLET: 1/4" G (M), OUTLET: 1/4" NPT (F)
COD.3002

90 cm max 250 bar 40 l/min, 180° C.
INLET: 1/4" G (M), OUTLET: 1/4" NPT (F)
COD.3003

120 cm max 250 bar 40 l/min, 180° C.
INLET: 1/4" G (M), OUTLET: 1/4" NPT (F)
COD.3004

150 cm max 250 bar 40 l/min, 180° C.
INLET: 1/4" G (M), OUTLET: 1/4" NPT (F)
COD.3005

170 cm max 250 bar 40 l/min, 180° C.
INLET: 1/4" G (M), OUTLET: 1/4" NPT (F)
COD.3006

200 cm max 250 bar 40 l/min, 180° C.
INLET: 1/4" G (M), OUTLET: 1/4" NPT (F)
COD.3007

SANDJET PROF

Kit lancia sabbiante.
Complete sandblasting kit.

Ø1,2 (1/4" G) **COD.3695**

Ø1,4 (1/4" G) **COD.3696**

Ø1,2 (M22 x 1,5) **COD.3697**

Ø1,4 (M22 x 1,5) **COD.3698**

Ø1,8 (M22 x 1,5) **COD.3699**

ROTOPOWER PROF 2

Ugello rotante alta pressione.
High pressure rotating nozzle.
M22x1,5mm fitting.

TTR Ø 1,25 **COD.40167**

TTR Ø 1,35 **COD.40169**

TPR Ø 1,40 **COD.40168**

TPR Ø 1,50 **COD.40173**

REG SPRAY 5

Kit testina con ugelli Spraying System.
Head gun kit with Spraying System nozzle.
M22x1,5mm fitting.

1504 **COD.3615**

1505 **COD.41274**

1507 **COD.3617**

15025 **COD.3618**

15055 **COD.3704**

DRE 115

Doppia lancia. • Double lance.
Max 280 bar 40 l/min, 150°C.
INLET: 1/4" G (M), OUTLET: 1/4" NPT (F)
COD.41105

WASH SPRAY

Kit testina. • Head gun kit.
M22x1,5mm fitting.
Ø1,1 White/Bianco **COD.40112**
Ø1 Green/Verde **COD.40113**
Ø1,25 Orange/Arancio **COD.40039**

Pistole

(Spray Guns)

MV 925

Pistola automatica. • Wash gun.
Max 310 bar 30 l/min, 160°C
INLET: 3/8" G (F), OUTLET: 1/4" G (F)
COD.41837

MV 2012

Pistola automatica. • Wash gun.
Max 350 bar 40 l/min, 160°C
INLET: 3/8" G (F) Swivel, OUTLET: 1/4" G (F)
COD.41378

AL 13 - 1/4"

Kit pistola per Wash Spray, Reg Spray 5, Rotopower Prof 2.
Gun kit for Wash Spray, Reg Spray 5, Rotopower Prof 2.
Max 255 bar 30 l/min, 60°C
INLET: 1/4" G (M), OUTLET: M22x1,5mm (F)
COD.41046

AL 13 - 3/8"

Kit pistola per Wash Spray, Reg Spray 5, Rotopower Prof 2.
Gun kit for Wash Spray, Reg Spray 5, Rotopower Prof 2.
Max 225 bar 30 l/min, 60°C
INLET: 3/8" G (M) OUTLET: M22x1,5mm (F)
COD.41045

Ugelli

(Nozzles)

WASH NOZZLES

Nozzle. • Ugello. 1/4 MEG 0°, 15°, 25°. Specificare nell'ordine il tipo di getto. (Vedi tabella pag. 158).
When ordering always state type of jet required. (See page 158).

(S)

UPT

Nozzle. • Ugello. 1/4 MEG 0°, 15°, 25°. Ugello pulizia tubazioni.
Pipe cleaning nozzle.
Max 120 bar 11 l/min, INLET: 1/4" G (M)
COD.1122190

PR

Portaugello regolabile.
Adjustable nozzle holder.
Max 250 bar 30 l/min, 150°C
INLET: 1/4" G (F), OUTLET: 1/4" NPT (F)
COD.3071

TDV

Testina doppio ugello. • Roller nozzles.
Max 200 bar 40 l/min, 90°C
INLET: 1/4" G (F), OUTLET: 2x1/4" NPT (F)
COD.3025

Tubi Alta Pressione

(HP Hoses)

SAE 100 R1 (10m)

Tubo alta pressione Ø 5/16" con raccordi.
5/16" high pressure hose with couplings.
Raccordi/Couplings 3/8" G (M) - 3/8" G (F)
COD.3118

Raccordi/Couplings 3/8" G (F) - 3/8" G (F)
COD.3122

SAE 100 R1 (16m)

Tubo alta pressione m 16.
High pressure hose kit.
Length 16m / 52 ft.
Ø 5/16", M22X1,5(F) - 1/4"G(F)
COD.1271900

SAE 100 R2 (10m)

Tubo alta pressione Ø 3/8" con raccordi.
3/8" high pressure hose with couplings.
Raccordi/Couplings 3/8" G (M) - 3/8" G (F)
COD.3119

Raccordi/Couplings 3/8" G (F) - 3/8" G (F)
COD.3120

HP8 PROF

Kit tubo alta pressione m 8.
Per AR 13-1/4".
High pressure hose kit. Length 8m / 26 ft.
For AR 13-1/4".
Ø 5/16", max. 315 bar
COD.3725

HP8

Kit tubo termoplastico alta pressione, per AR 13-1/4".
Thermoplastic HP hose kit, for AR 13-1/4".
Ø 1/4" max.160 bar
COD.40102
Ø 5/16" max.160 bar
COD.40104

Flanges and Couplers

A » Z



F6

Flangia pompe serie XT, Xj, RC, C version per motori elettrici B3/B14 Gr.90.
Flange XT, Xj, RC series C version for close coupling B3/B14 90 frame.
COD.1581



F16

Flangia pompe serie XM, RK C version per motori elettrici B3/B14 Gr.100 e 112.
Flange XM, RK series C version for close coupling B3/B14 100 and 112 frame.
COD.1590



F44

Flangia pompe serie RC C version per motori elettrici B3/B14 Gr.100.
Flange RC series C version for close coupling B3/B14 100 frame.
COD.41053



F7

Flangia pompe serie XT, Xj, RCV D version per motori a scoppio con albero cilindrico 3/4" (19,05 mm) e flangia SAE J609a.
Flange XT, Xj, RCV series D version for close coupling to gas/diesel engines with 3/4" cylindrical shaft and SAE J609a flange.
COD.1579



F17

Flangia pompe serie XM, RK E version per motori elettrici NEMA 182-184 (Ø 1" 1/8).
Flange XM, RK series E version for close coupling NEMA 182-184 (Ø1" 1/8 shaft).
COD.1591



F45

Flangiatura con giunto elastico pompe serie RC per motori elettrici B3/B14 Gr. 90.
Bell housing + flexible coupling RC series for B3/B14 frame 90.
COD.1560



F8

Flangia pompe serie XT, Xj, RCA, RCV E version per motori elettrici NEMA 56-C.
Flange XT, Xj, RCA, RCV series E version for close coupling NEMA 56-C.
COD.1584



F25

Flangia pompe serie XM D version per motori a scoppio con albero cilindrico 3/4" (19,05 mm) e flangia SAE J609a.
Flange XM series D version for close coupling to gas/diesel engines with 3/4" cylindrical shaft and SAE J609a flange.
COD.1585



F46

Flangiatura con giunto elastico pompe serie RC, RR per motori elettrici B3/B14 Gr. 100/112.
Bell housing + flexible coupling RC, RR series for B3/B14 frame 100/112.
COD.1566



F9

Flangia pompe serie XT, Xj, RC per motori elettrici speciali AR.
Flange XT, Xj, RC series for close coupling AR special electric motors.
COD.1580



F28

Flangiatura con giunto elastico pompe serie RG, RW, XW, XWL, SXW per motori elettrici B3/B14 Gr.100 e 112.
Bell housing + flexible coupling RG, RW, XW, XWL, SXW series for B3/B14 frame 100 and 112.
COD.1543

F50

Flangiatura con giunto elastico pompe modelli RTX per motori idraulici tipo SAE J744 B101-2, B101-4.
Bell housing + flexible coupling RTX models for hydraulic motors SAE J744 B101-2, B101-4 type.
COD.41450



F10

Flangiatura pompe serie XT, RC per motori elettrici B3/B14 Gr. 90.
Bell housing + solid coupling XT, RC series for B3/B14 frame 90.
COD.1582



F30

Flangiatura con giunto elastico pompe serie XM, RK, RG, RW, XW, XWL, SXW per motori elettrici B3/B14 Gr.132-160S.
Bell housing + flexible coupling XM, RK, RG, RW, XW, XWL, SXW series for B3/B14 frame 132, 160S.
COD.1545



F11

Flangiatura pompe serie XT per motori elettrici B3/B14 Gr. 100.
Bell housing + solid coupling XT series for B3/B14 frame 100.
COD.1583



F32

Flangia pompe serie XM E version Ø 5/8" per motori elettrici NEMA 56-C.
Flange XM series E version Ø 5/8" for close coupling NEMA 56-C.
COD.1578



F13

Flangiatura con giunto elastico pompe serie XM, RK, RCW per motori elettrici B3/B14 Gr.100 e 112.
Bell housing + flexible coupling XM, RK, RCW series for B3/B14 frame 100 and 112.
COD.1587



F40

Flangia pompe serie RS, XM 'D' version per motori a scoppio con albero cilindrico 1" (25,4 mm) e flangia SAE J609a.
Flange RS, XM series 'D' version for close coupling to gas/diesel engines with 1" cylindrical shaft and SAE J609a flange.
COD.1542



F14

Flangiatura con giunto elastico pompe serie XMA, RKA per motori elettrici NEMA 182-184 (albero Ø 1" 1/8).
Bell housing + flexible coupling XMA, RKA series for NEMA 182-184(Ø1" 1/8 shaft).
COD.1588



F41

Flangia pompe serie RK 'D' version per motori a scoppio con albero cilindrico 1" (25,4 mm) e flangia SAE J609a.
Flange RK series 'D' version for close coupling to gas/diesel engines with 1" cylindrical shaft and SAE J609a flange.
COD.1541



F15

Flangiatura con giunto elastico pompe serie XMA, RKA per motori elettrici NEMA 213-215 (albero Ø 1" 3/8).
Bell housing + flexible coupling XMA, RKA series for NEMA 213-215 (Ø1" 3/8 shaft).
COD.1589



Other accessories

A » Z

ATC



Regolatore automatico dell'acceleratore motore a scoppio.
Automatic Throttle Control.

Max 250 bar.
COD.51534

FAS



Filtro aspirazione.
Suction strainer.

Max 10 bar, max 20 l/min.
INLET: 1/2" G (F), OUTLET: 1/2" G (M)
COD.3000



Filtro aspirazione.
Aluminium suction strainer.

Max 10 bar, max 20 l/min.
INLET: 1/2" G (F), OUTLET: 1/2" G (M)
COD.3121



Max 14 bar, max 80 l/min.
INLET: 3/4" G (F), OUTLET: 3/4" G (F)
COD.50031

FD



Filtro aspirazione detergente.
Detergent suction filter.

COD.1341030

FDR



Filtro aspirazione detergente con valvola di non ritorno.
Detergent suction filter with check valve.

COD.3116

FS



Galleggiante.
Float.

Max 8 bar 21 l/min, 60° C.
INLET: Ø 27 mm
COD.3114

JETTER VALVE



Jetter valve.

XT, XM series
RC series
RK series
XW series

COD.40235

COD.41003

COD.40161

COD.40236

IDF



Iniettore detergente fisso.
Detergent injector.

TYPE	INLET	OUTLET	CHEM Ø mm	COD.
1,8	3/8" G(F)	3/8" G(M)	8	3060
2,1	3/8" G(F)	3/8" G(M)	8	3061
2,3	3/8" G(F)	3/8" G(M)	8	3062
1,8	3/8" G(M)	3/8" G(M)	8	3033
2,1	3/8" G(M)	3/8" G(M)	8	3034

IDR



Iniettore detergente regolabile.
Adjustable detergent injector.

TYPE	INLET	OUTLET	CHEM Ø mm	COD.
1,8	3/8" G(F)	3/8" G(M)	8	3057
2,1	3/8" G(F)	3/8" G(M)	8	3058
2,3	3/8" G(F)	3/8" G(M)	8	3059
1,8	3/8" G(M)	3/8" G(M)	8	3035
2,1	3/8" G(M)	3/8" G(M)	8	3036

IR



Innesti rapidi. • *Quick couplings.*

TYPE	RING NUT	COUPLING Ø	COD.
IR 06	without/senza	3/8" G (F)	3044
IR 07	without/senza	1/4" G (F)	3045
IR 08	without/senza	3/8" G(M)	3046
IR 09	without/senza	1/4" G(M)	3047



Innesti rapidi. • *Quick couplings.*

TYPE	RING NUT	COUPLING Ø	COD.
IR 6	with/con	3/8" G (F)	3048
IR 7	with/con	1/4" G (F)	3049
IR 8	with/con	3/8" G(M)	3050
IR 9	with/con	1/4" G(M)	3051



MCS



Manometro.
Max 250 bar, attacco 1/4" G (M) centrale posteriore, Ø 63 mm.
Pressure gauge.
Max 250 bar, 1/4" G (M) rear central attachment, Ø 63 mm.

COD.3001

Max 315 bar, attacco 1/4" G (M) centrale posteriore, Ø 63 mm.
Max 315 bar, 1/4" G (M) rear central attachment, Ø 63 mm.

COD.41031

MH



Manometro.
Max 150 bar, attacco 1/8" G (M) centrale posteriore, Ø 40 mm.
Pressure gauge.
Max 150 bar, 1/8" G (M) rear central attachment, Ø 40 mm.

COD.3223



Max 315 bar, attacco 1/4" G (M) centrale posteriore, Ø 50 mm.
Max 315 bar, 1/4" G (M) rear central attachment, Ø 50 mm.

COD.1381580

MR



Manometro.
Max 250 bar, attacco 1/4" G (M) laterale, Ø 63 mm.
Pressure gauge.
Max 250 bar, 1/4" G (M) bottom attachment, Ø 63 mm.

COD.740260

Max 315 bar, 1/4" G (M) bottom attachment, Ø 63 mm.
Max 315 bar, attacco 1/4" G (M) laterale, Ø 63 mm.

COD.41032

PD



Accumulatore.
Pulsation dampener.
Max 250 bar, -15 +80 °C, INLET: 1/2" G (F)
COD.50046

PX



Pressostato.
Pressure switch.
40-250 bar, 12-250 Vca, 15A, 90° C
COD.51368

KIT B



Piedi. • <i>Base.</i>	COD.
XT, XTA	1836
XM, XMS, XMA, XHW	2729
RC, RCA, RCS, RR, RRA	42376
RK, RKA, RHW	2729
RG, RW, XW, XWA, SXW, WHW, WHWL, SHP, SHPA, RGX, RGXA, XWP	2748

KIT C



Kit C per XWT • *Kit C for XWT.*
COD.2519





Tabella portate teoriche con pressioni in bar, portate in L/min e Ø foro equivalente in mm
Theoretical flow chart with pressures in bar, flows in L/min and equivalent nozzle diameter in mm

Nozzle	OUTPUT IN L/1' AT THE INDICATED PRESSURE • PORTATE IN L/1' ALLE PRESSIONI INDICATE																				
Type MEG	Ø mm	20	30	40	50	60	70	80	90	100	110	120	130	140	150	160	170	180	190	200	210
..015	0,80	1,5	1,9	2,2	2,4	2,6	2,9	3,1	3,2	3,4	3,6	3,7	3,9	4,0	4,2	4,3	4,5	4,6	4,7	4,8	5,0
..02	0,91	2,0	2,5	2,9	3,2	3,5	3,8	4,1	4,3	4,6	4,8	5,0	5,2	5,4	5,6	5,8	5,9	6,1	6,3	6,4	6,6
..025	1,00	2,5	3,1	3,6	4,0	4,4	4,8	5,1	5,4	5,7	6,0	6,2	6,5	6,7	7,0	7,2	7,4	7,6	7,9	8,1	8,3
..03	1,09	3,1	3,7	4,3	4,8	5,3	5,7	6,1	6,5	6,8	7,2	7,5	7,8	8,1	8,4	8,6	8,9	9,2	9,4	9,7	9,9
..035	1,12	3,6	4,4	5,0	5,6	6,2	6,7	7,1	7,6	8,0	8,4	8,7	9,1	9,4	9,8	10,1	10,4	10,7	11,0	11,3	11,6
..04	1,19	4,1	5,0	5,8	6,4	7,1	7,6	8,2	8,6	9,1	9,6	10,0	10,4	10,8	11,2	11,5	11,9	12,2	12,6	12,9	13,2
..045	1,27	4,6	5,6	6,5	7,2	7,9	8,6	9,2	9,7	10,3	10,8	11,2	11,7	12,1	12,6	13,0	13,4	13,8	14,1	14,5	14,9
..05	1,35	5,1	6,2	7,2	8,1	8,8	9,5	10,2	10,8	11,4	11,9	12,5	13,0	13,5	14,0	14,4	14,9	15,3	15,7	16,1	16,5
..055	1,40	5,6	6,9	7,9	8,9	9,7	10,5	11,2	11,9	12,5	13,1	13,7	14,3	14,8	15,3	15,9	16,3	16,8	17,3	17,7	18,2
..06	1,47	6,1	7,5	8,6	9,7	10,6	11,4	12,2	13,0	13,7	14,3	15,0	15,6	16,2	16,7	17,3	17,8	18,3	18,8	19,3	19,8
..065	1,52	6,6	8,1	9,4	10,5	11,5	12,4	13,2	14,0	14,8	15,5	16,2	16,9	17,5	18,1	18,7	19,3	19,9	20,4	20,9	21,5
..07	1,60	7,1	8,7	10,1	11,3	12,4	13,3	14,3	15,1	15,9	16,7	17,5	18,2	18,9	19,5	20,2	20,8	21,4	22,0	22,6	23,1
..075	1,65	7,6	9,4	10,8	12,1	13,2	14,3	15,3	16,2	17,1	17,9	18,7	19,5	20,2	20,9	21,6	22,3	22,9	23,6	24,2	24,8
..08	1,70	8,2	10,0	11,5	12,9	14,1	15,2	16,3	17,3	18,2	19,1	20,0	20,8	21,6	22,3	23,1	23,8	24,5	25,1	25,8	26,4
..085	1,75	8,7	10,6	12,2	13,7	15,0	16,2	17,3	18,4	19,4	20,3	21,2	22,1	22,9	23,7	24,5	25,2	26,0	26,7	27,4	28,1
..09	1,80	9,2	11,2	13,0	14,5	15,9	17,2	18,3	19,5	20,5	21,5	22,5	23,4	24,3	25,1	25,9	26,7	27,5	28,3	29,0	29,7
..095	1,85	9,7	11,9	13,7	15,3	16,8	18,1	19,4	20,5	21,6	22,7	23,7	24,7	25,6	26,5	27,4	28,2	29,0	29,8	30,6	31,4
..10	1,90	10,2	12,5	14,4	16,1	17,6	19,1	20,4	21,6	22,8	23,9	25,0	26,0	27,0	27,9	28,8	29,7	30,6	31,4	32,2	33,0
..11	1,98	11,2	13,7	15,9	17,7	19,4	21,0	22,4	23,8	25,1	26,3	27,5	28,6	29,7	30,7	31,7	32,7	33,6	34,5	35,4	36,3
..12	2,08	12,2	15,0	17,3	19,3	21,2	22,9	24,5	25,9	27,3	28,7	29,9	31,2	32,3	33,5	34,6	35,6	36,7	37,7	38,7	39,6
..125	2,13	12,7	15,6	18,0	20,1	22,1	23,8	25,5	27,0	28,5	29,9	31,2	32,5	33,7	34,9	36,0	37,1	38,2	39,3	40,3	41,3
..13	2,16	13,2	16,2	18,7	20,9	22,9	24,8	26,5	28,1	29,6	31,1	32,4	33,8	35,0	36,3	37,5	38,6	39,7	40,8	41,9	42,9
..14	2,26	14,3	17,5	20,2	22,6	24,7	26,7	28,5	30,3	31,9	33,5	34,9	36,4	37,7	39,1	40,3	41,6	42,8	44,0	45,1	46,2
..15	2,34	15,3	18,7	21,6	24,2	26,5	28,6	30,6	32,4	34,2	35,8	37,4	39,0	40,4	41,9	43,2	44,6	45,8	47,1	48,3	49,5
..16	2,41	16,3	20,0	23,1	25,8	28,2	30,5	32,6	34,6	36,5	38,2	39,9	41,6	43,1	44,6	46,1	47,5	48,9	50,2	51,6	52,8
..18	2,54	18,3	22,5	25,9	29,0	31,8	34,3	36,7	38,9	41,0	43,0	44,9	46,8	48,5	50,2	51,9	53,5	55,0	56,5	58,0	59,4
..20	2,69	20,4	25,0	28,8	32,2	35,3	38,1	40,8	43,2	45,6	47,8	49,9	52,0	53,9	55,8	57,6	59,4	61,1	62,8	64,4	66,0
..25	2,99	25,5	31,2	36,0	40,3	44,1	47,7	50,9	54,0	57,0	59,7	62,4	64,9	67,4	69,8	72,0	74,3	76,4	78,5	80,6	82,5
..30	3,30	30,6	37,4	43,2	48,3	52,9	57,2	61,1	64,8	68,3	71,7	74,9	77,9	80,9	83,7	86,5	89,1	91,7	94,2	96,7	99,0
..40	3,80	40,8	49,9	57,6	64,4	70,6	76,2	81,5	86,5	91,1	95,6	99,8	103,9	107,8	111,6	115,3	118,8	122,3	125,6	128,9	132,1
..50	4,20	50,9	62,4	72,0	80,6	88,2	95,3	101,9	108,1	113,9	119,5	124,8	129,9	134,8	139,5	144,1	148,5	152,8	157,0	161,1	165,1
..60	4,70	61,1	74,9	86,5	96,7	105,9	114,4	122,3	129,7	136,7	143,4	149,7	155,9	161,7	167,4	172,9	178,2	183,4	188,4	193,3	198,1

Nozzle output must not exceed 90 ÷ 95% of pump's output • La portata dei getti non deve superare il 90 ÷ 95% della portata della pompa.



Nozzle	OUTPUT IN L/1' AT THE INDICATED PRESSURE • PORTATE IN L/1' ALLE PRESSIONI INDICATE																				
Type MEG	Ø mm	220	230	240	250	260	270	280	290	300	325	350	375	400	425	450	475	500	525	550	600
..015	0,80	5,1	5,2	5,3	5,4	5,5	5,6	5,7	5,8	5,9	6,2	6,4	6,6	6,8	7,0	7,2	7,4	7,6	7,8	8,0	8,4
..02	0,91	6,8	6,9	7,1	7,2	7,3	7,5	7,6	7,8	7,9	8,2	8,5	8,8	9,1	9,4	9,7	9,9	10,2	10,4	10,7	11,2
..025	1,00	8,4	8,6	8,8	9,0	9,2	9,4	9,5	9,7	9,9	10,3	10,7	11,0	11,4	11,7	12,1	12,4	12,7	13,1	13,4	14,0
..03	1,09	10,1	10,4	10,6	10,8	11,0	11,2	11,4	11,6	11,8	12,3	12,8	13,2	13,7	14,1	14,5	14,9	15,3	15,7	16,0	16,7
..035	1,12	11,8	12,1	12,4	12,6	12,9	13,1	13,3	13,6	13,8	14,4	14,9	15,4	15,9	16,4	16,9	17,4	17,8	18,3	18,7	19,5
..04	1,19	13,5	13,8	14,1	14,4	14,7	15,0	15,2	15,5	15,8	16,4	17,0	17,6	18,2	18,8	19,3	19,9	20,4	20,9	21,4	22,3
..045	1,27	15,2	15,5	15,9	16,2	16,5	16,8	17,2	17,5	17,8	18,5	19,2	19,9	20,5	21,1	21,7	22,3	22,9	23,5	24,0	25,1
..05	1,35	16,9	17,3	17,6	18,0	18,4	18,7	19,1	19,4	19,7	20,5	21,3	22,1	22,8	23,5	24,2	24,8	25,5	26,1	26,7	27,9
..055	1,40	18,6	19,0	19,4	19,8	20,2	20,6	21,0	21,3	21,7	22,6	23,4	24,3	25,1	25,8	26,6	27,3	28,0	28,7	29,4	30,7
..06	1,47	20,3	20,7	21,2	21,6	22,0	22,5	22,9	23,3	23,7	24,6	25,6	26,5	27,3	28,2	29,0	29,8	30,6	31,3	32,1	33,5
..065	1,52	22,0	22,5	22,9	23,4	23,9	24,3	24,8	25,2	25,6	26,7	27,7	28,7	29,6	30,5	31,4	32,3	33,1	33,9	34,7	36,3
..07	1,60	23,7	24,2	24,7	25,2	25,7	26,2	26,7	27,2	27,6	28,8	29,8	30,9	31,9	32,9	33,8	34,8	35,7	36,5	37,4	39,1
..075	1,65	25,3	25,9	26,5	27,0	27,6	28,1	28,6	29,1	29,6	30,8	32,0	33,1	34,2	35,2	36,2	37,2	38,2	39,2	40,1	41,9
..08	1,70	27,0	27,6	28,2	28,8	29,4	29,9	30,5	31,0	31,6	32,9	34,1	35,3	36,5	37,6	38,7	39,7	40,8	41,8	42,7	44,6
..085	1,75	28,7	29,4	30,0	30,6	31,2	31,8	32,4	33,0	33,5	34,9	36,2	37,5	38,7	39,9	41,1	42,2	43,3	44,4	45,4	47,4
..09	1,80	30,4	31,1	31,8	32,4	33,1	33,7	34,3	34,9	35,5	37,0	38,4	39,7	41,0	42,3	43,5	44,7	45,8	47,0	48,1	50,2
..095	1,85	32,1	32,8	33,5	34,2	34,9	35,6	36,2	36,9	37,5	39,0	40,5	41,9	43,3	44,6	45,9	47,2	48,4	49,6	50,8	53,0
..10	1,90	33,8	34,6	35,3	36,0	36,7	37,4	38,1	38,8	39,5	41,1	42,6	44,1	45,6	47,0	48,3	49,7	50,9	52,2	53,4	55,8
..11	1,98	37,2	38,0	38,8	39,6	40,4	41,2	41,9	42,7	43,4	45,2	46,9	48,5	50,1	51,7	53,2	54,6	56,0	57,4	58,8	61,4
..12	2,08	40,6	41,5	42,4	43,2	44,1	44,9	45,7	46,6	47,4	49,3	51,1	52,9	54,7	56,4	58,0	59,6	61,1	62,6	64,1	67,0
..125	2,13	42,2	43,2	44,1	45,0	45,9	46,8	47,7	48,5	49,3	51,3	53,3	55,1	57,0	58,7	60,4	62,1	63,7	65,3	66,8	69,8
..13	2,16	43,9	44,9	45,9	46,8	47,8	48,7	49,6	50,4	51,3	53,4	55,4	57,4	59,2	61,1	62,8	64,6	66,2	67,9	69,5	72,5
..14	2,26	47,3	48,4	49,4	50,4	51,4	52,4	53,4	54,3	55,2	57,5	59,7	61,8	63,8	65,8	67,7	69,5	71,3	73,1	74,8	78,1
..15	2,34	50,7	51,8	52,9	54,0	55,1	56,2	57,2	58,2	59,2	61,6	63,9	66,2	68,3	70,5	72,5	74,5	76,4	78,3	80,1	83,7
..16	2,41	54,1	55,3	56,5	57,6	58,8	59,9	61,0	62,1	63,1	65,7	68,2	70,6	72,9	75,1	77,3	79,4	81,5	83,5	85,5	89,3
..18	2,54	60,8	62,2	63,5	64,8	66,1	67,4	68,6	69,8	71,0	73,9	76,7	79,4	82,0	84,5	87,0	89,4	91,7	94,0	96,2	100,5
..20	2,69	67,6	69,1	70,6	72,0	73,5	74,9	76,2	77,6	78,9	82,1	85,2	88,2	91,1	93,9	96,7	99,3	101,9	104,4	106,9	111,6
..25	2,99	84,5	86,4	88,2	90,1	91,8	93,6	95,3	97,0	98,7	102,7	106,6	110,3	113,9	117,4	120,8	124,1	127,4	130,5	133,6	139,5
..30	3,30	101,4	103,7	105,9	108,1	110,2	112,3	114,4	116,4	118,4	123,2	127,9	132,4	136,7	140,9	145,0	149,0	152,8	156,6	160,3	167,4
..40	3,80	135,2	138,2	141,2	144,1	146,9	149,7	152,5	155,2	157,8	164,3	170,5	176,5	182,3	187,9	193,3	198,6	203,8	208,8	213,7	223,2
..50	4,20	169,0	172,8	176,5	180,1	183,7	187,2	190,6	194,0	197,3	205,4	213,1	220,6	227,8	234,8	241,7	248,3	254,7	261,0	267,2	279,0
..60	4,70	202,8	207,3	211,8	216,1	220,4	224,6	228,7	232,8	236,8	246,4	255,7	264,7	273,4	281,8	290,0	297,9	305,7	313,2	320,6	334,8

Nozzle output must not exceed 90 ÷ 95% of pump's output • La portata dei getti non deve superare il 90 ÷ 95% della portata della pompa.

